



STRONG ARM

ADVANCED MODEL ROCKET

Assembly and Operation Instructions

BEFORE YOU BEGIN:

- Study the illustrations and sequence of assembly. The sequence of assembly is important. Review the parts list and become familiar with all parts before assembly. If any parts are missing or damaged, contact AEROTECH™ at 1-702-641-2301.
- **DO NOT MODIFY THE DESIGN OF THE ROCKET.** Changes to the design of the rocket such as, but not limited to, reducing the fin size, shortening the body tube, or modifying the motor tube assembly can adversely affect the flight stability of the rocket.
- Only use AEROTECH™ Composite Model Rocket Motors in this model rocket. See Motor Matrix for recommended AEROTECH motors.

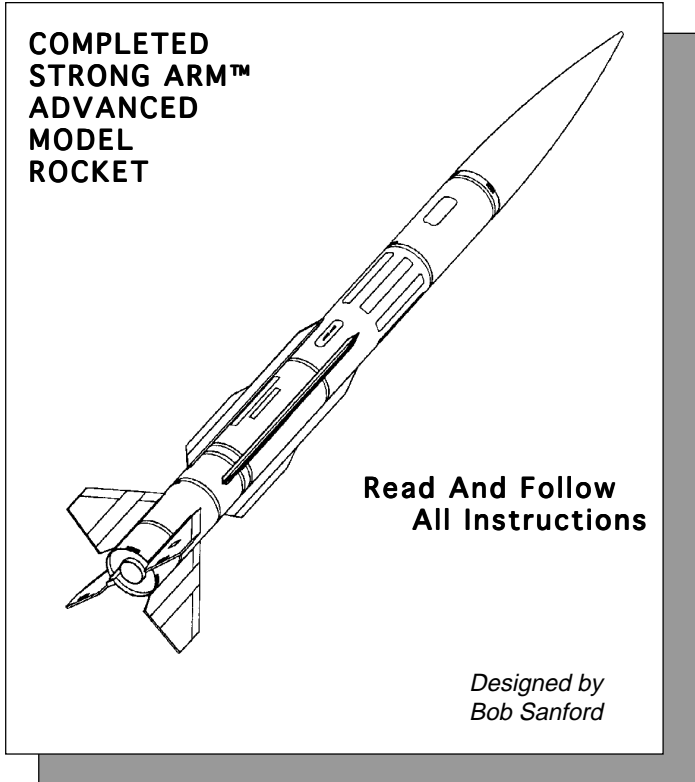

Read and follow the Model Rocket Safety Code of the National Association of Rocketry (NAR) and comply with all federal, state and local laws in all activities with model rockets.

PARTS:

Motor adaptor tube (4-7/8"/124mm)	(12421)	1	Screw eye	(19015)	1
Adaptor rings (1/2"/13mm)	(14001)	2	Shock cord (8/2.4m)	(17388)	1
"E" spacer tube (2-1/8"/54mm)	(14002)	1	Lower Body Tube(15"/38cm) Slotted	(12614)	1
Thrust ring (7/16"/11mm)	(14010)	1	Upper Body Tube(15"/38cm)Unslotted	(12615)	1
Thrust ring flange (1/16"/1.6mm)	(14011)	1	Launch lugs	(19035)	2
Motor tube (12"/30.5cm)	(12912)	1	Nose cone (2-19/32"/6.6cm)	(11261)	1
Motor hook	(19001)	1	Adhesive decal sheet	(18017)	1
FIN-LOK™ rings-4 fin	(19344)	2	Parachute (30"/76cm diameter)	(13030)	1
Centering rings (2-17/32"/64mm)	(16629)	3	"F" spacer tube (1"/25mm)	(14003)	1
Fins	(11714)	4	Coupler Tube (6"/15cm)	(12606)	1
Cooling mesh	(19011)	1	Strakes	(18917)	4
Ejection gas baffle	(19030)	1	Instructions	(19917)	1

ASSEMBLY INSTRUCTIONS: (Use medium viscosity cyanoacrylate cement.)

MOTOR ADAPTOR

1. Lightly sand the motor adaptor tube and then slide an adaptor ring onto the tube until the end of the ring is flush with the end of the tube. This ring marks the front end of the adaptor tube. Slide the other adaptor ring onto the other end of the adaptor tube until the back edge of the ring is 3/4" (19 mm) from the back end of the tube. Apply beads of cement where the rings meet the adaptor tube.
2. Insert the "E" motor spacer tube into the motor adaptor tube and position it at the front end of the adaptor tube. DO NOT cement in place.

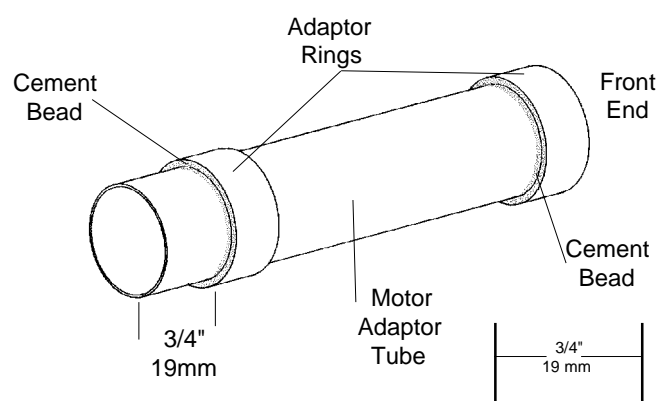

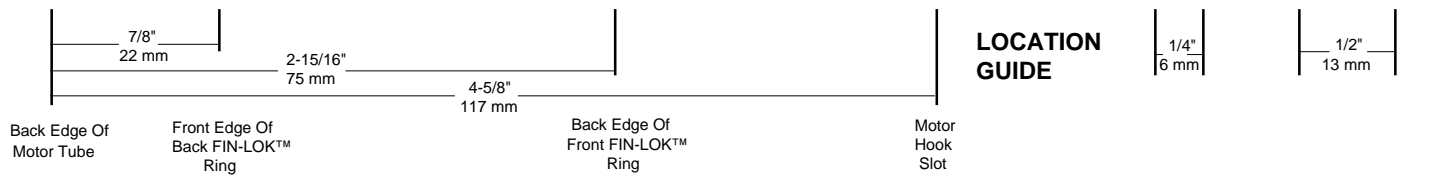

MOTOR TUBE ASSEMBLY

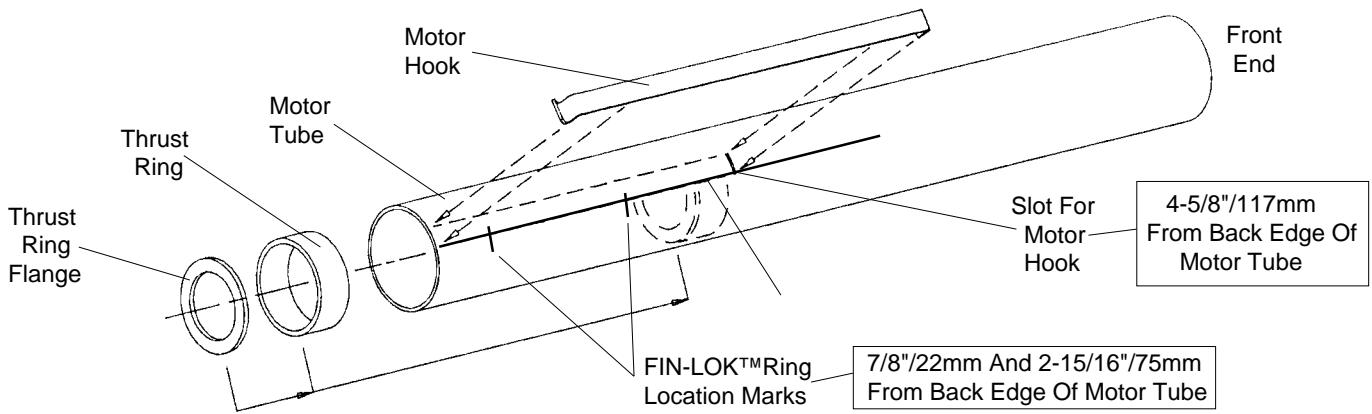

1. Cement the thrust ring flange (1/16"/1.6 mm thick) to the thrust ring (7/16"/11 mm long). Set the thrust ring assembly aside to dry.
2. Find the line drawn along the side of the motor tube. Using the Location Guide printed along the top edge of this instruction sheet, cut a 1/4" (6 mm) long slot 4-5/8" (117mm) from the back end of the motor tube and next to the line on the motor tube as shown.
3. Using the Location Guide, make a mark along the motor tube line 2-15/16" (75 mm) from the **back end** of the motor tube. This mark locates where the **back edge** of the front FIN-LOK™ ring will be. Make another mark 7/8" (22 mm) from the **back end** of the motor tube. This mark locates where the **front edge** of the rear most FIN-LOK™ ring will be.
4. Insert the tab of the motor hook into the slot cut into the motor tube. **Use a small dowel to apply several drops of cement around the inside the motor tube just behind where the motor hook comes through the motor tube wall.** Then, with the thrust ring flange facing the back, insert the thrust ring assembly into the motor tube. Use the motor adaptor to push the thrust ring assembly forward until it stops against the tab of the motor hook. Remove the motor adaptor.

FIN-LOK™ ASSEMBLY

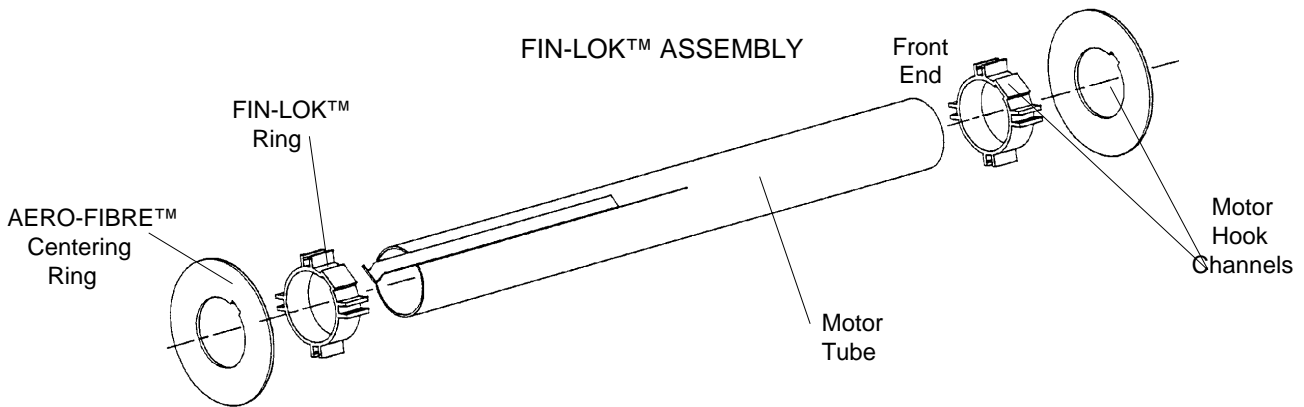

NOTE: FROM THIS POINT ON, DO NOT USE ANY CEMENT UNTIL REACHING ASSEMBLY STEP 5.

1. With their motor hook channels aligned with the motor hook, slide a FIN-LOK™ ring and then an AERO-FIBRE™ centering ring over the **front end** of the motor tube. Push on the centering ring until the **back edge** of the FIN-LOK™ ring is moved to the forward most mark made in Step 3 above. (**NOTE:** The rings are designed to be a tight fit on the motor tube. If the rings are difficult to slide onto the motor tube, round the inside edges of the rings with sandpaper. If the FIN-LOK™ rings need to be turned
2. Slide the other FIN-LOK™ ring and then a centering ring over the **back end** of the motor tube. Push on the centering ring until the **front edge** of the FIN-LOK™ ring is at the rear-most mark made in Step 3.
3. Using the line on the motor tube as a guide, gently twist the back centering ring slightly until the fin locks of the back FIN-LOK™ ring are aligned with the fin locks of the front FIN-LOK™ ring.

after they are on the motor tube, use a small piece of cloth to provide a better grip.)

FIN-LOK™ ASSEMBLY (CONT.)

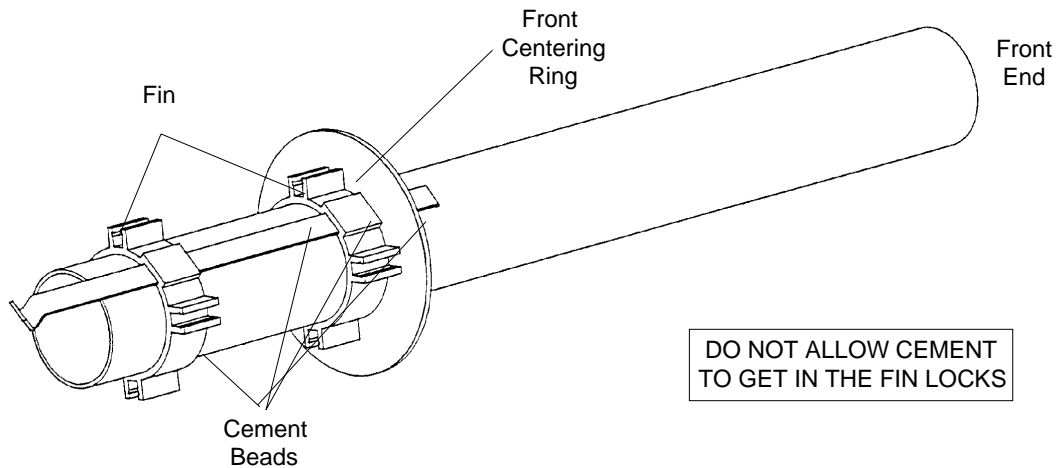

4. Test the proper positioning and alignment of the FIN-LOK™ rings by snapping the fins into the fin locks. If any fin does not snap into place, check to see that each FIN-LOK™ ring is the correct distance from the back end of the motor tube and that the fin has no plastic flashing left from production that may be preventing a proper fit. Remove any plastic flashing with a hobby knife or sandpaper. After making any adjustments, carefully remove the fins **and the back centering ring**. Check that the front centering ring is still positioned next to and touching the front FIN-LOK™ ring.
5. Apply a bead of cement where the front centering ring meets the motor tube. Without getting cement into any of the finlocks, apply cement only to the areas **BETWEEN** the finlocks where the front FIN-LOK™ ring meets the front centering ring and the motor tube.
6. Without getting cement into any of the fin locks, apply cement only to the areas **BETWEEN** the fin locks where only the **front edge** of the back FIN-LOK™ ring meets the motor tube. **DO NOT** apply cement to the back edge of the back FIN-LOK™ ring. (**NOTE:** The unique AEROTECH FIN-LOK™ fin mounting system carries and distributes aerodynamic and thrust loads throughout an integrated rocket structure in a manner found in large aerospace vehicles. Loads are primarily borne by structural members and not cement.)
7. Apply a bead of cement around the motor hook forward of the front centering ring.

LABYRINTH™ ASSEMBLY

DO NOT CEMENT COOLING MESH INTO MOTOR TUBE

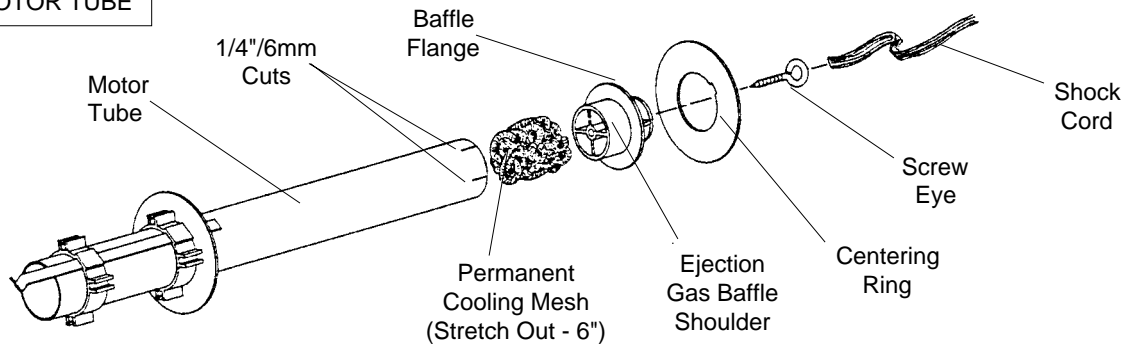

1. Make four 1/4" (6mm) long cuts, 90 degrees apart, in the front end of the motor tube.
2. Stretch out the cooling mesh to about 6" (15cm) in length. Insert the cooling mesh into the **front end** of the motor tube. (**NOTE:** Do **not** cement the mesh into the motor tube.)
3. Apply a **thin film** of cement to the front 2/3rd's of the shoulder of the ejection gas baffle and insert the baffle shoulder into the front end of the motor tube.
4. **Apply beads of cement where the baffle meets the motor tube and into each of the cuts in the motor tube.**
5. Apply cement to the front surface of the baffle flange and place an AERO-FIBRE™ centering ring over the front end of the baffle so it rests upon the baffle flange.
6. Screw the screw eye all the way into the hole at the front end of the baffle. Securely tie an end of the shock cord to the screw eye with a square knot. (**CAUTION:** Do **not** put cement on the knot of the shock cord. Cement will weaken the shock cord.)

BODY AND FIN ASSEMBLY - PART 1

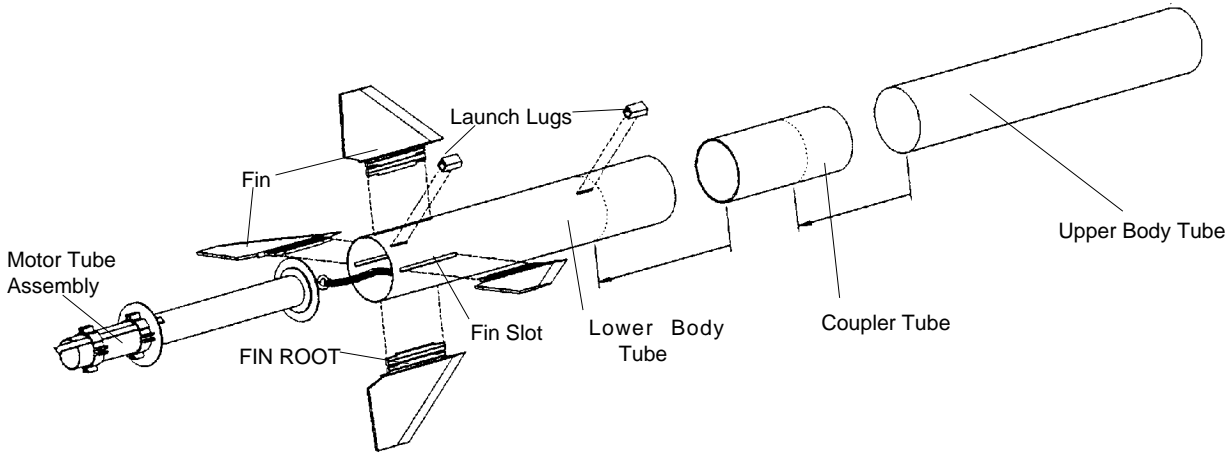

- Using a hobby knife, carefully remove any body tube material that may still be attached to any pre-cut slots in the lower, slotted body tube.
- Insert the loose end of the shock cord and then the motor tube assembly into the back of the rocket body tube as shown. Position the motor tube assembly so that the fin locks are located under and visible through the body tube's pre-cut fin slots.
- Apply cement along the full length of the fin root of a fin (area that makes contact with the outside surface of the body tube). Carefully insert the fin through a slot in the body tube and snap the fin into place. Repeat this process for the other three fins. (NOTE: Each fin should be snug against the body tube.)
- Through the back end of the body tube apply cement where the fin tabs meet the motor tube. Through the front end of the body tube, apply cement where the baffle assembly centering ring meets the inside surface of the body tube.
- Insert the tube coupler into the lower body tube to check its fit. Remove the coupler and run a bead of cement around the inside of the lower body tube above the baffle centering ring. Pass the shock cord through the tube coupler and press the coupler down into the top of the lower body tube until it stops against the baffle centering ring. Allow the cement to dry.
- Test fit the upper body tube on to the lower body assembly/coupler. Remove the upper body tube and apply a bead of cement inside the upper tube about 1" (25mm) from the back end. Slide the upper body tube over the tube coupler and push it down until it stops against the lower body tube. Check to make certain that the upper and lower body tubes are in line with each other.
- Lightly sand the surface of the lower body tube around the launch lug slots. Apply cement to the base of a launch lug. With the sloping portion of the launch lug toward the front of the body tube, insert the tab on the bottom of the lug into one of the pre-cut launch lug slots in the body tube. Repeat this process for the other launch lug.

Strake Measurements

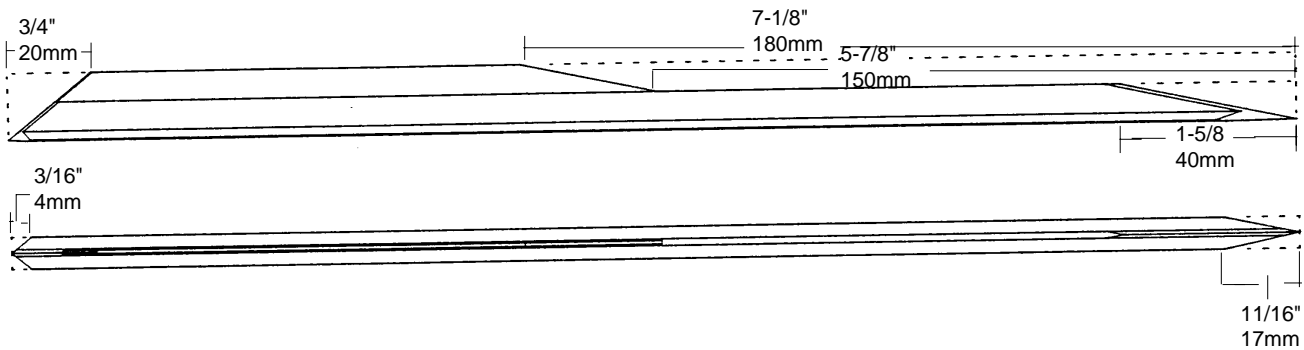

BODY AND FIN ASSEMBLY - PART 2

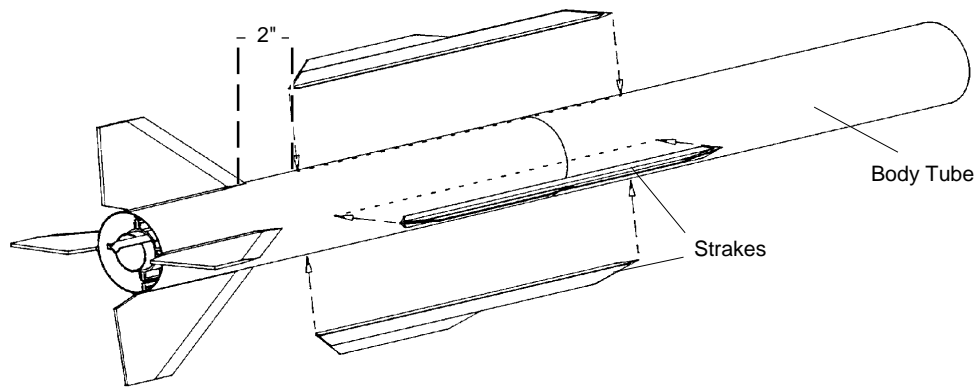

1. Using the strake measurement guide (page 4), mark and cut each of the four strakes to the proper shape.
2. Wrap the strake marking guide around the body tube making sure to line up the alignment arrows with the fins. Using a pencil or pen, make marks at the arrow points shown on the strake marking guide. Remove the marking guide and using a straight edge, connect the marks made on the tube along the length axis.
3. Using the location guide at the top of the page, measure the distance from the front of each fin to the edge of the guide (2"/51mm). Make a mark at this distance along all 4 strake alignment lines.
4. Apply cement to the base of a strake. Place the back edge of the strake against the mark measured in step 3 and press it against the body tube while centering the strake over one of the lines drawn in step 2. Wipe away any excess cement. Repeat this step for the remaining three strakes.

FINAL ASSEMBLY AND FINISHING

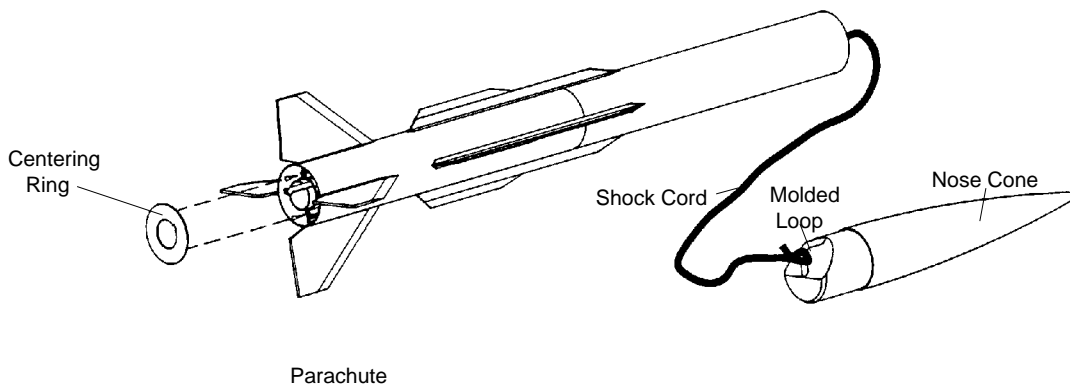

1. Slide the remaining centering ring over the back of the motor tube and motor hook and push it against the back FIN-LOK™ ring. Apply a bead of cement where the centering ring meets the body tube.
2. To recreate the color scheme shown on the box cover, paint the rocket body white. (**CAUTION:** Make sure the paint is compatible with high impact polystyrene plastic.)
3. Carefully cut out the self adhesive decals and apply them. Extra decals are provided to allow the modeler to customize the STRONG ARM's finished appearance.
4. Paint the nose cone. The box cover model has a medium gray color nose cone. (**CAUTION:** Do **not** paint the portion of the nose cone that fits inside the body tube (the shoulder). Paint on the shoulder may cause the nose cone to stick and hinder or prevent parachute ejection.)
5. Securely tie the loose end of the shock cord to the loop molded into the shoulder of the nose cone with a square knot. (**CAUTION:** Do **not** put cement on the knot of the shock cord. Cement will weaken the shock cord.)
6. Fasten the fabric parachute to the shock cord at a point about one (1) foot away from the nose cone in the following manner. Stretch out the shroud lines of the parachute so that the lines form three (3) loops one on top of the other. Lay the shock cord across all the shroud lines. Pass the canopy of the parachute over the shock cord and through the three (3) loops made by the shroud lines and pull tight. Pack the parachute and insert the nose cone into the body tube.

DECAL PLACEMENT

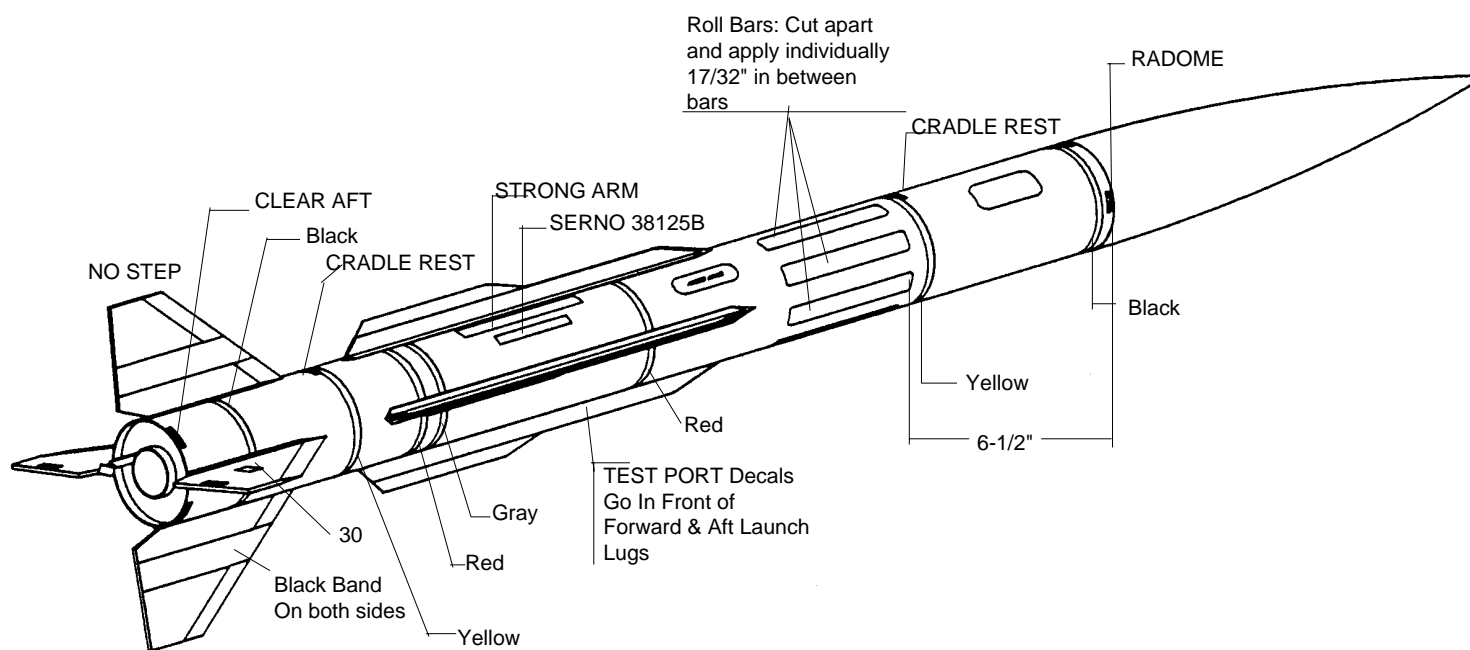

DECAL INSTRUCTIONS

1. Handle the decal sheet carefully to avoid damage. Do not crease the decal sheet.
2. Use a pair of sharp scissors or a hobby knife to cut out the decals.
3. Cutting out decals that will be positioned close together on the rocket as one block will make them easier to apply.
4. Make smooth cuts. Small knicks can cause a decal to tear when it is being peeled off the backing sheet.
5. Before starting to peel decals off their backings, fill a soup bowl with warm water and put one or two drops of a dishwashing detergent into the water.
6. Carefully peel a decal off its backing, dip it into the detergent solution and apply the decal to the rocket. The detergent solution prevents the adhesive on the decal from "grabbing" the rocket surface too quickly and allows accurate positioning of the decal.
7. Gently press any air bubbles out from under the decal and then dab the decal dry.
8. Apply the rest of the decals in the same manner.

OPERATION INSTRUCTIONS

1. **RECOMMENDED MOTORS:** Only use AEROTECH composite model rocket motors when flying your AEROTECH rocket. See enclosed chart for recommended motors and projected altitudes.
2. **RECOVERY SYSTEM PREPARATION:** Roll the parachute and shroud lines, starting from the canopy peak, into a loose cylinder that will easily slide into the lower body assembly body tube. Pack the long portion of the shock cord into the body tube first. Next, insert the parachute. Finally, insert the short length of shock cord into the body tube on top of the parachute and put on the nose cone (or payload bay if your rocket has one). Make sure that the parachute, shroud lines and shock cord are not caught between the body tube and the shoulder of the nose cone or payload bay. The nose cone or payload bay should slide freely. (**NOTE:** Because your AEROTECH rocket has the LABYRINTH™ ejection gas cooling system, no recovery wadding is required.)
3. **MOTOR PREPARATION:** The motors recommended for your AEROTECH rocket vary in physical size as well as performance. Your rocket comes with a changeable motor adaptor and spacer tubes that permit the the rocket to use each of the recommended motors without permanent modification to the rocket.

Prepare your AEROTECH rocket motor according to the instructions that come with the motor. Be sure the motor hook snaps in behind the nozzle end of the motor and holds the motor securely in place. If the motor hook does not hold the motor in place, bend the end of the hook until it does.

4. **PRE-LAUNCH CHECKOUT:** Before **EVERY** flight, perform a complete pre-launch checkout of your rocket;
 - Check that all fins and launch lugs are mounted securely and not damaged.
 - Examine the body tube, nose cone and payload bay to make sure they are free of damage.
 - Check that the shock cord is securely mounted to the ejection gas baffle and nose cone (or payload bay bulkhead).
 - Check that the parachute is securely tied to the shock cord.
 - Check that the shock cord and parachute are free of any damage.
 - See that the nose cone (or payload bay), packed parachute and shock cord move freely. After awhile, an ejection charge residue may build up at the top inside surface of the body tube. Wipe this residue away with isopropyl ("rubbing") alcohol.
 - With the tail of the rocket pointed down and the motor tube empty, shake the rocket to remove any loose ejection charge debris left from a previous flight. Periodically, fluff up the cooling mesh using a bent wire inserted through the back end of the motor tube.
 - Be certain the motor to be used is a recommended AEROTECH model rocket motor and of a size appropriate for the launch area.
 - Be sure the motor hook, motor adaptor and motor tube are not damaged and hold the motor securely in place.

If the pre-launch checkout reveals any damage, **repair the damage** before the rocket is flown again.

5. **LAUNCH PAD:** Your AEROTECH rocket must be flown from a launch pad with a 1/4" (6.4mm) diameter metal launch rod at least 36" (0.9m) long (as measured from the top of the blast deflector), such as the AEROTECH MANTIS™ model rocket launch pad.
6. **MOTOR IGNITION:** Only launch your rocket using a remotely controlled and electrically operated launch controller such as the AEROTECH® INTERLOCK™ model rocket launch controller. Keep yourself and all other people at least 30 feet (10 meters) away from the rocket during launch.
7. **LAUNCH AREA:** Launch the rocket in a cleared outdoor area free of tall trees, power lines and buildings. The side dimensions of the cleared area should be at least one half of the projected altitude. An area for a radius of at least 5 feet (1.5 meters) from the launcher should be clear of dry grass or other flammable substances. Read and follow the Model Rocket Safety Code of the National Association of Rocketry (NAR) and comply with all federal, state and local laws in all activities with model rockets. A copy of the NAR safety code is shown on the instructions that come with all AEROTECH composite model rocket motors.
8. **FLIGHT PROFILE:** When the launch button of the electrical launch controller is pressed, an electrical current causes the AEROTECH COPPERHEAD™ single lead igniter to ignite the composite propellant of the AEROTECH rocket motor. The motor quickly builds up thrust and powers your AEROTECH rocket into the air. During powered flight the rocket increases in speed and altitude. When the propellant burns out the rocket is moving at maximum velocity and a time delay material (delay grain) inside the motor burns. While the delay grain burns the rocket coasts to peak altitude at which point the delay grain ignites the ejection charge within the forward part of the motor. The ignition of the ejection charge creates a burst of hot expanding gas which is cooled by the permanent metal mesh of the LABYRINTH™ ejection gas cooling system. The cooled gas flows around the baffle, pressurizes the parachute bay and ejects the nose cone (or payload bay) and parachute. The parachute then deploys and gently returns the rocket to the ground where the rocket can be prepared for another flight.
9. **TRANSPORT AND STORAGE:** To avoid damage to your AEROTECH rocket during transport, pack it in a box surrounded by soft packing. Store your rocket at room temperature.

NOTICE: AEROTECH certifies that it has exercised reasonable care in the design and manufacture of its products. As we cannot control the storage and use of our products, once sold we cannot assume any responsibility for product storage, transportation or usage. AEROTECH shall not be held responsible for any personal injury or property damage resulting from the handling, storage or use of our product. The buyer assumes all risks and liabilities therefrom and accepts and uses AEROTECH products on these conditions.

No warranty either expressed or implied is made regarding AEROTECH products, except for replacement or repair, at AEROTECH's option, of those products which are proven to be defective in manufacture within one year from the date of original purchase. For repair or replacement under this warranty, please contact AEROTECH. Proof of purchase will be required. Note: Your state may provide additional rights not covered by this warranty.

ATTENTION!

READ THIS BEFORE FLYING YOUR STRONG ARM™

The AEROTECH STRONG ARM™ Advanced Model Rocket loaded with an AEROTECH "E", "F" or "G" motor weighs more than one (1) pound at liftoff. When flying a model rocket that weighs over one (1) pound at liftoff you must observe certain FAA regulations.

Federal Aviation Administration (FAA) regulations (FAR 101-subpart C) currently require that anyone planning to launch a model rocket weighing over one (1) pound but no more than 3.3 pounds at liftoff must notify (such as by telephone call) the nearest FAA Air Traffic Control (ATC) facility no less than 24 hours and no more than 48 hours in advance of the launch of such a rocket and provide the following information:

- a) The names and addresses of the operators; except when there are multiple participants at a single event; the name and address of the person so designated as the event launch coordinator, whose duties include coordination of the required launch data estimates and coordinating the launch event;
- b) The estimated number of rockets to be operated;
- c) The estimated size and estimated weight of each rocket; and
- d) The estimated highest altitude or flight level to which each rocket will be operated.
- e) The location of the operation.
- f) The date, time, and duration of the operation.
- g) Any other pertinent information requested by the ATC facility.

Rockets weighing over one (1) pound but no more than 3.3 pounds at liftoff must not be launched within 5 miles of an airport runway or other landing area unless the information listed above is also provided to the manager of that airport.

In addition, no person may operate an unmanned rocket that weighs over one (1) pound but no more than 3.3 pounds at liftoff:

- 1) In a manner that creates a collision hazard with other aircraft.
- 2) At an altitude where clouds or obscuring phenomena of more than five/tenths coverage prevails.
- 3) At any altitude where the horizontal visibility is less than five (5) miles.
- 4) Into any cloud.

Read and follow the Model Rocket Safety Code of the National Association of Rocketry (NAR) and comply with all federal, state and local laws in all activities with model rockets.

FLY SAFELY!

ALIGNMENT GUIDE

STRAKE

Alignment

FIN

STRAKE

FIN

STRAKE

FIN

STRAKE

FIN

Alignment

Alignment

Alignment