

# Venture<sup>T.M.</sup>

I N S T R U C T I O N S

© 1993 Custom Rocket Company

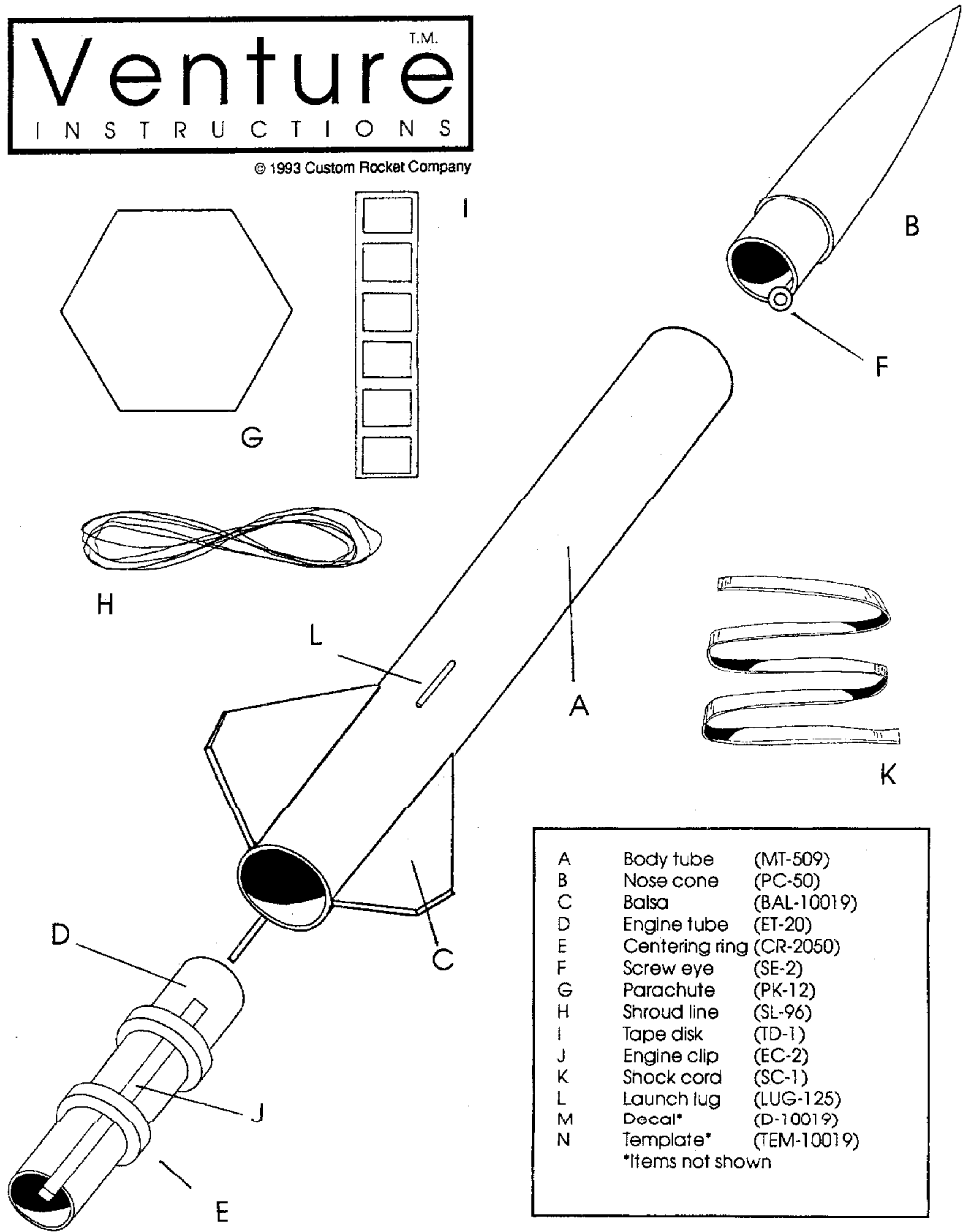

A	Body tube	(MT-509)
B	Nose cone	(PC-50)
C	Balsa	(BAL-10019)
D	Engine tube	(ET-20)
E	Centering ring	(CR-2050)
F	Screw eye	(SE-2)
G	Parachute	(PK-12)
H	Shroud line	(SL-96)
I	Tape disk	(TD-1)
J	Engine clip	(EC-2)
K	Shock cord	(SC-1)
L	Launch lug	(LUG-125)
M	Decal*	(D-10019)
N	Template*	(TEM-10019)
*Items not shown		

1

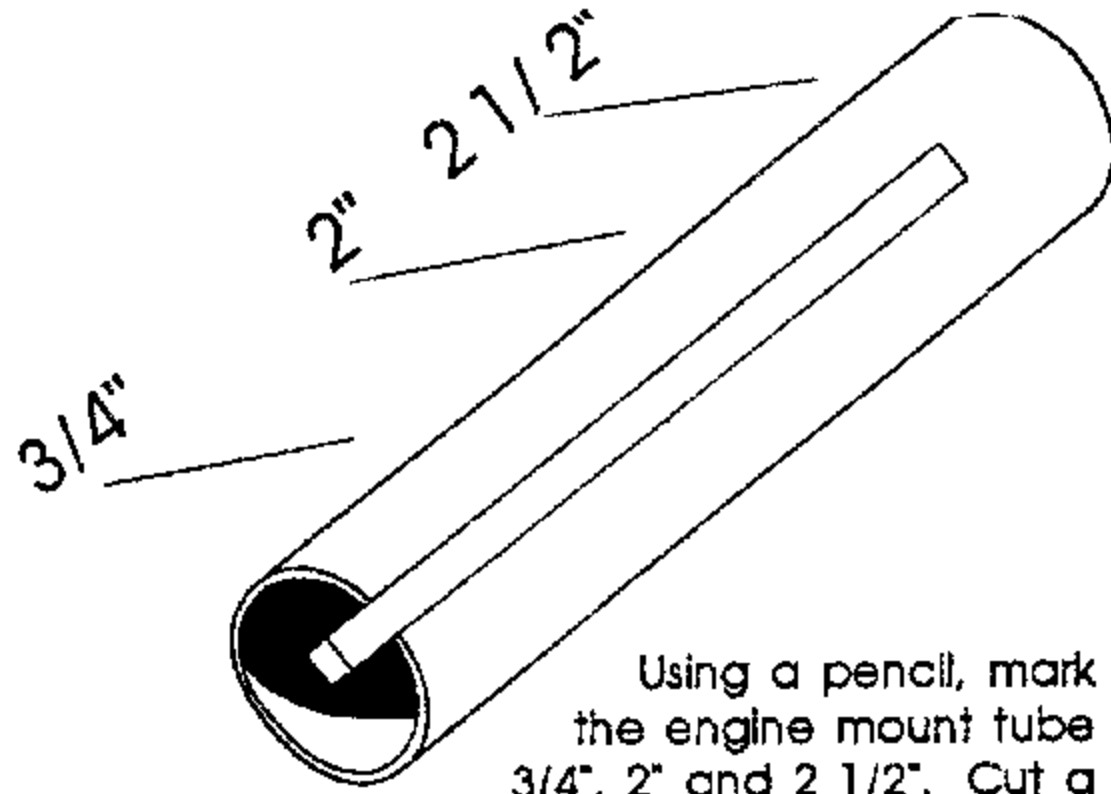

Using a pencil, mark the engine mount tube  $3/4$ ",  $2$ " and  $2\ 1/2$ ". Cut a  $1/8$ " slit at the  $2\ 1/2$ " mark and insert the engine clip into the slot. Take the centering rings and slide them onto the tube at the  $3/4$ " and  $2$ " marks.

2

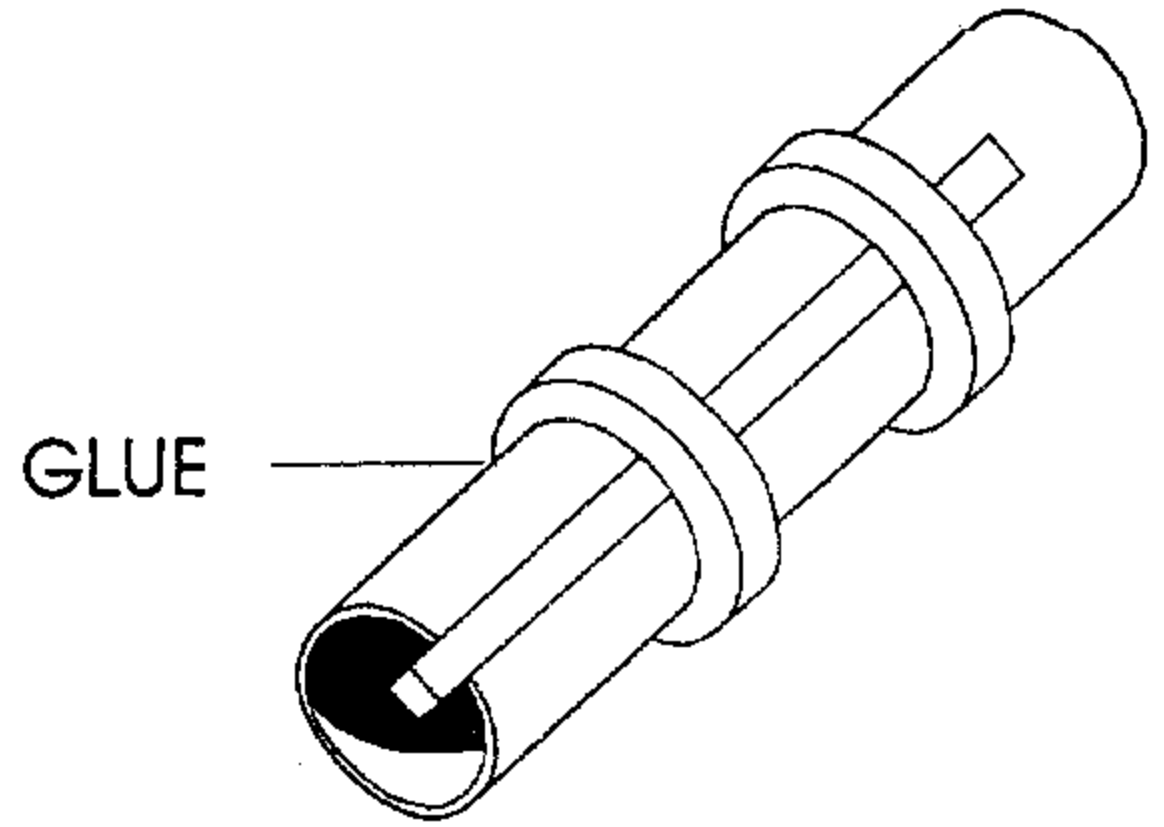

Apply white glue to the joints on all of the rings. Let this motor mount completely dry before going to the next step. It's very important not to rush this step!

3

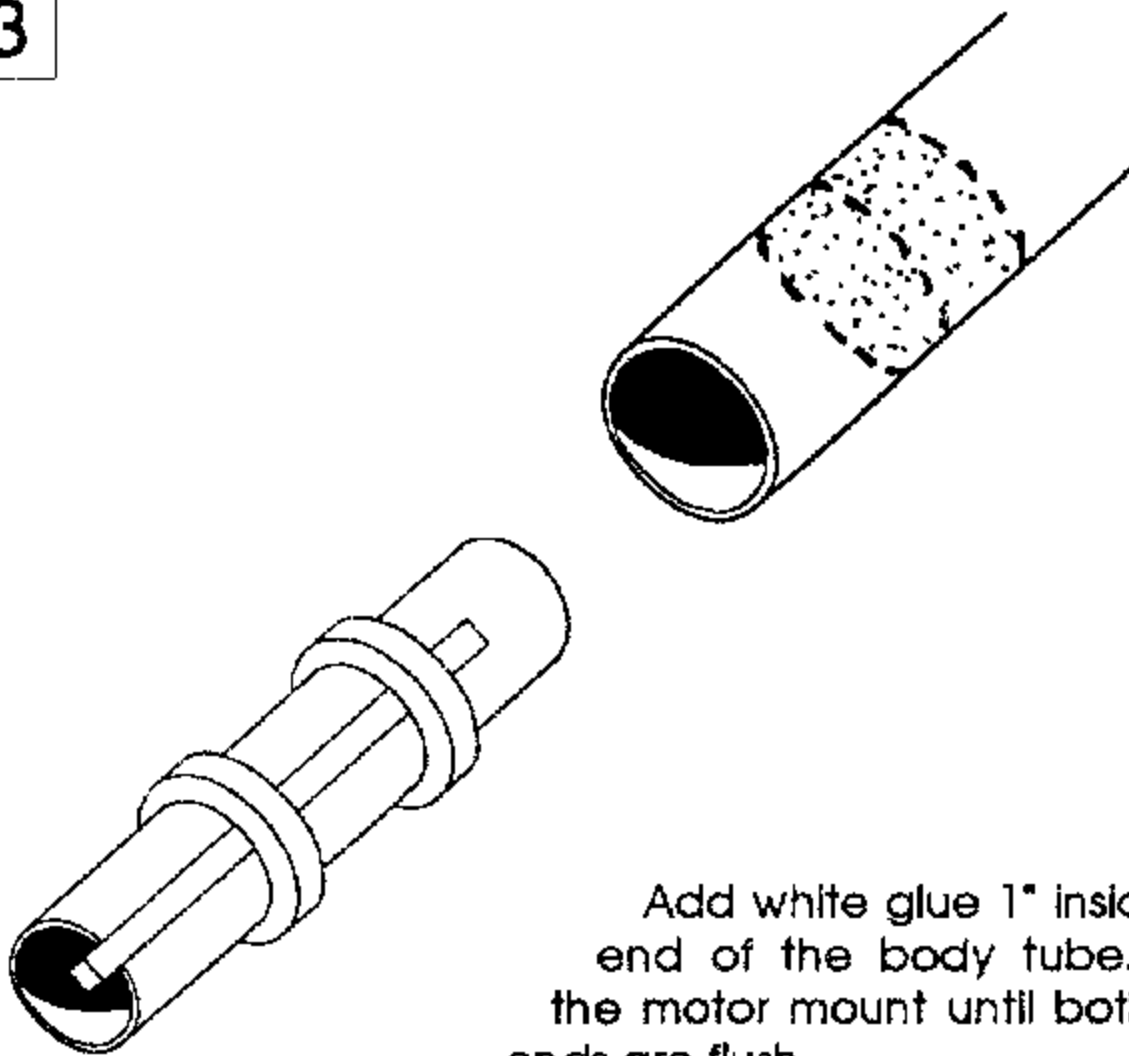

Add white glue  $1$ " inside one end of the body tube. Insert the motor mount until both tube ends are flush.

4

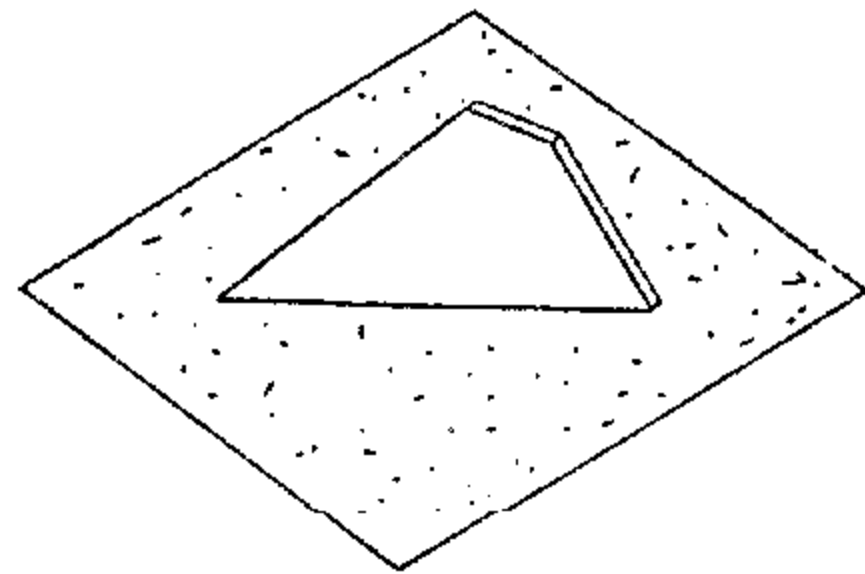

Cut and sand the balsa with fine sandpaper.

5

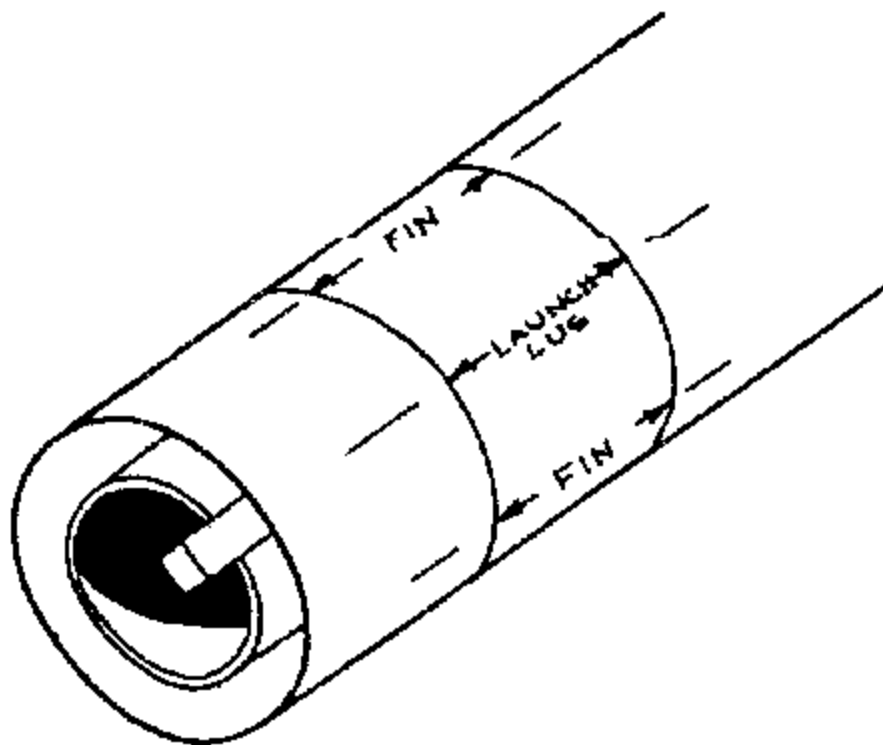

Cut out the fin placement template and wrap it around the tube. Use a pencil and mark the fin and launch lug locations. Notice where the engine clip is in the drawing.

6

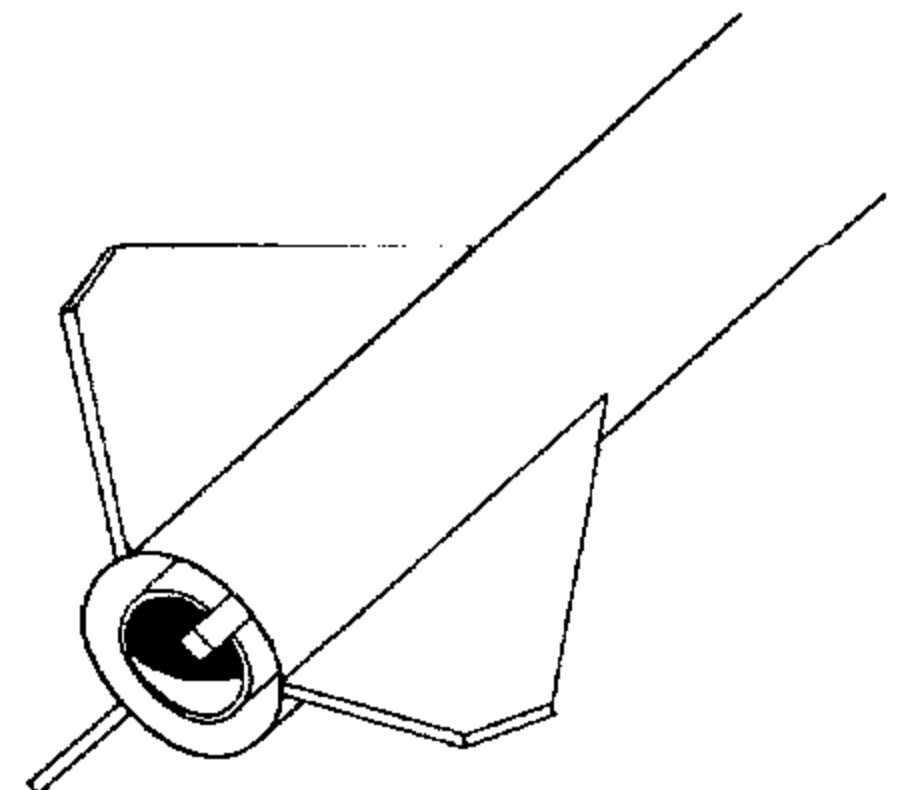

Glue on the fins one at a time with white glue. Wait for each fin to dry before applying the next fin.

7

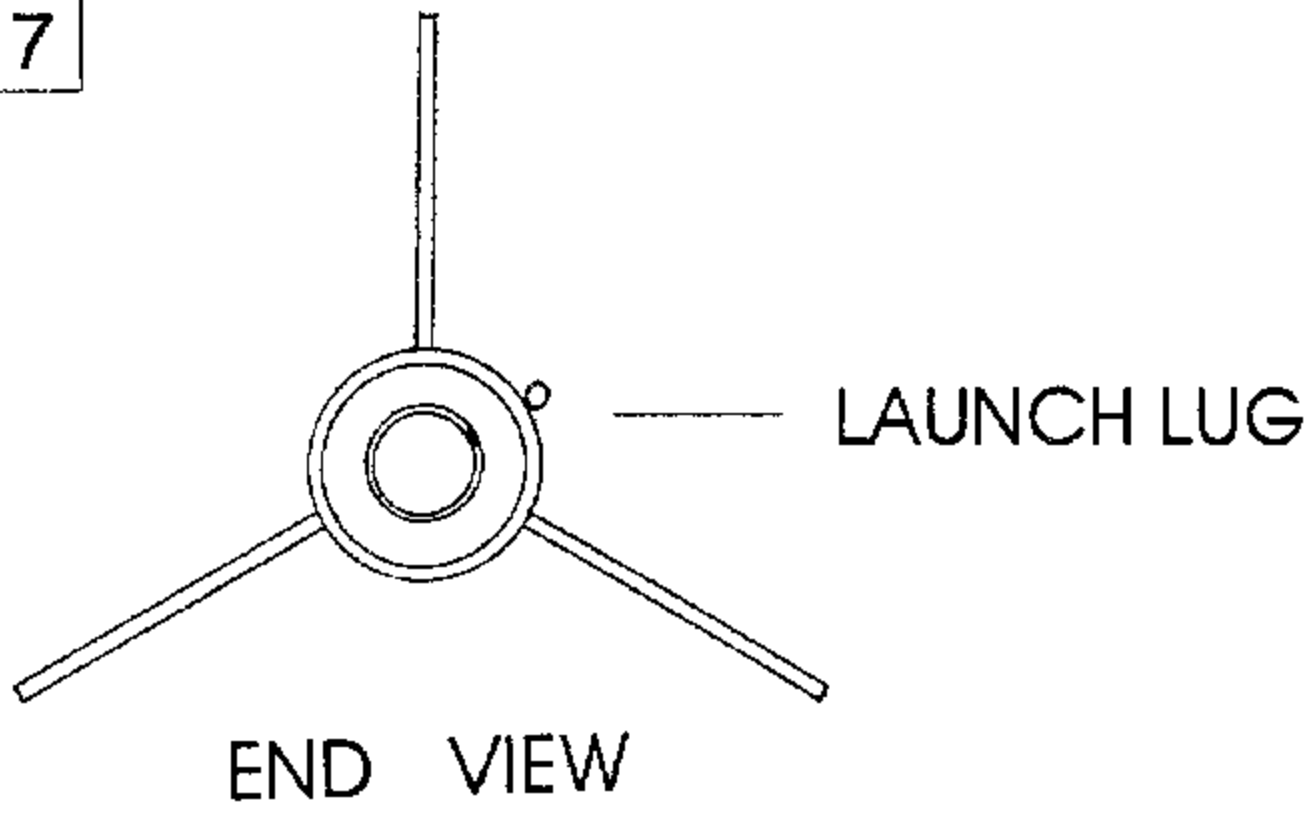

This is how the end view should look.

8

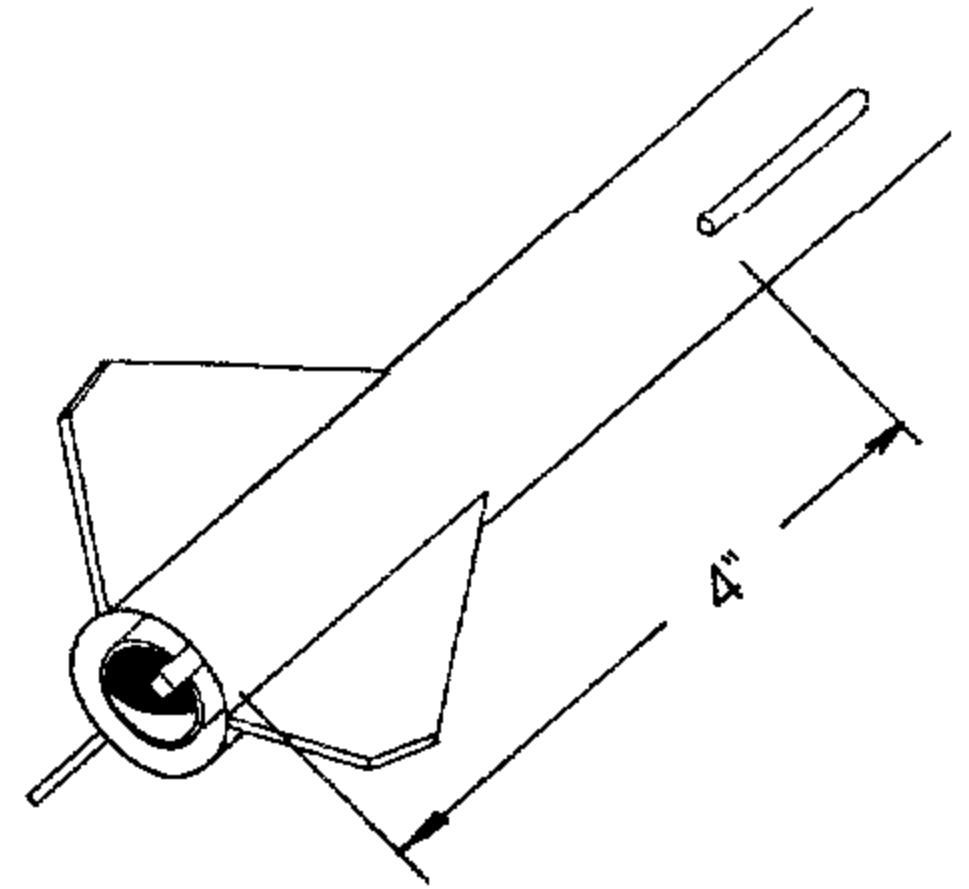

Glue the launch lug 4" from the end.

9

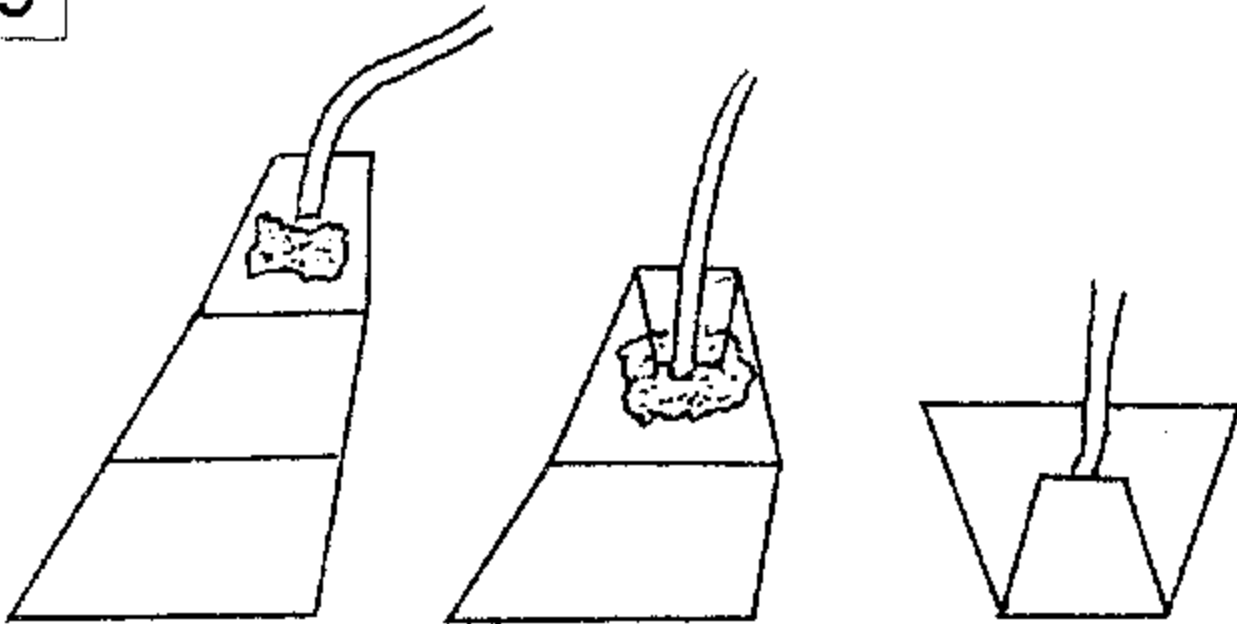

- A. Cut out the shock cord mount & apply glue to section 1. Lay the end of the shock cord into the glue.
- B. Fold section 1 at fold line and squeeze with your fingers.
- C. Apply glue to the back of section 1 and fold to section 3. Put complete assembly under a heavy object.

10

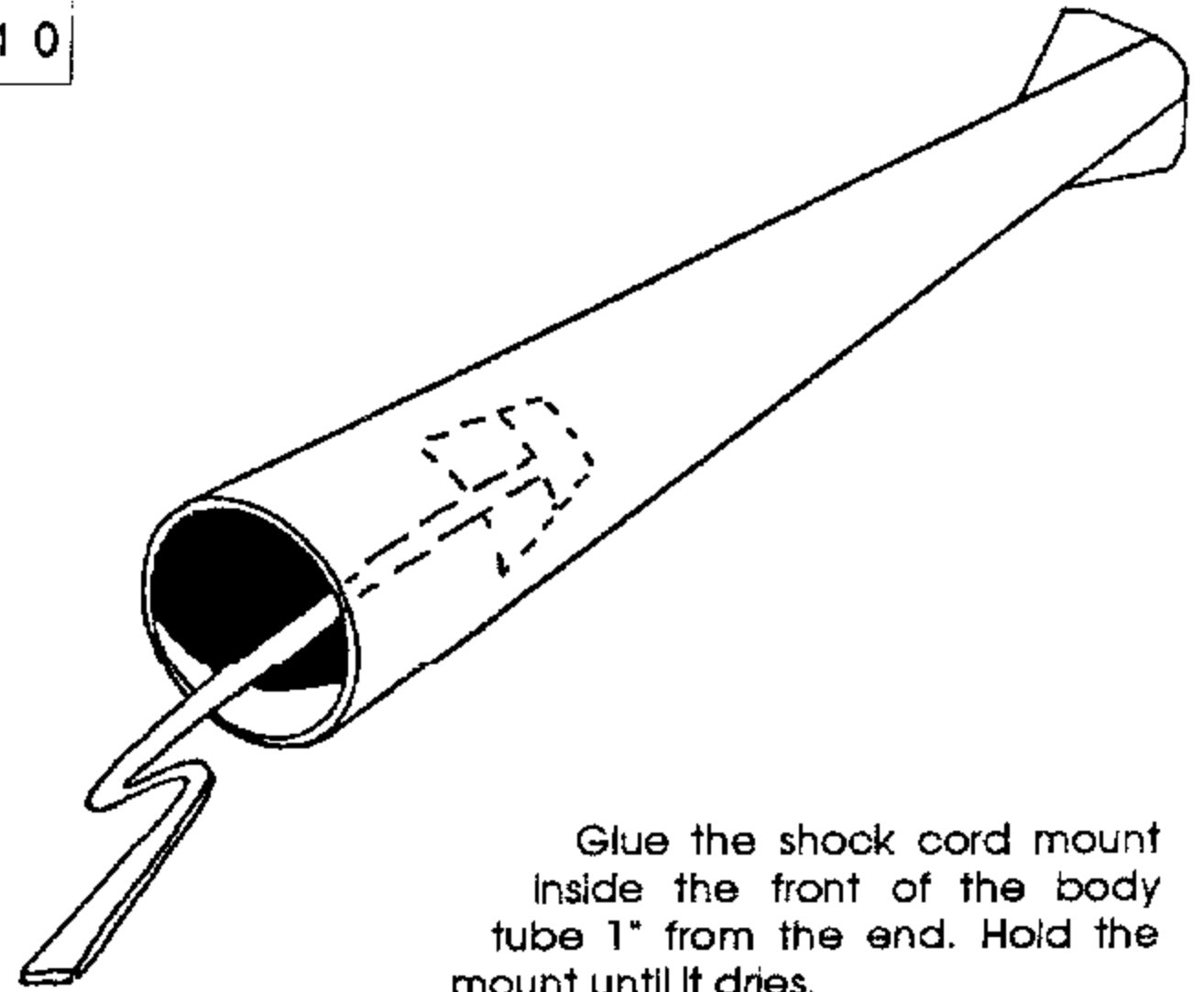

Glue the shock cord mount inside the front of the body tube 1" from the end. Hold the mount until it dries.

11

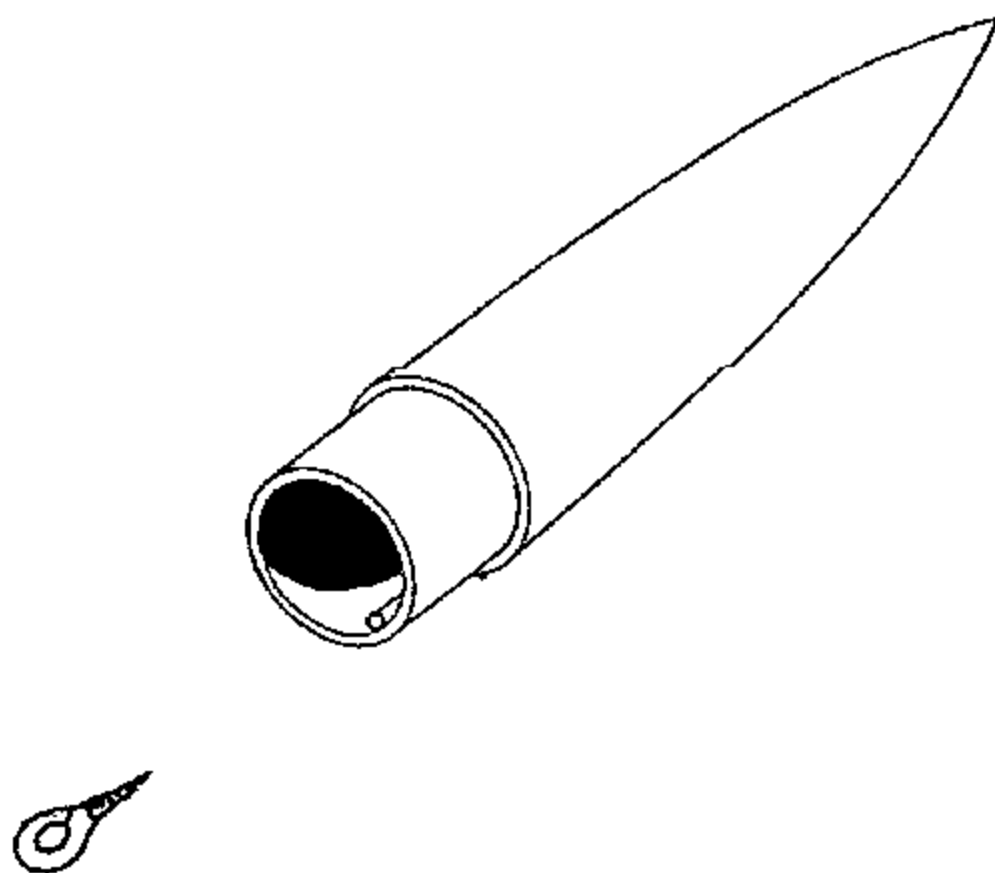

Insert the screw eye into the nose cone.

12

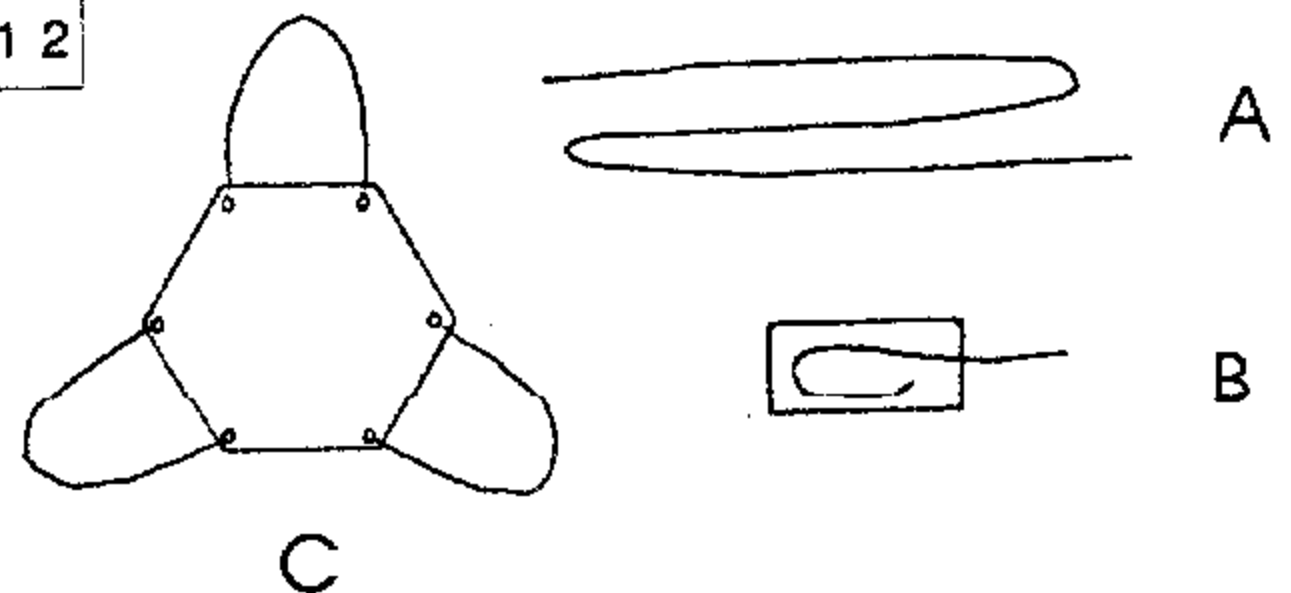

- A Cut the shroud line into three equal parts
- B Attach the end of the shrouds to the tape disks.
- C Tape the disks to the parachute as shown.

13

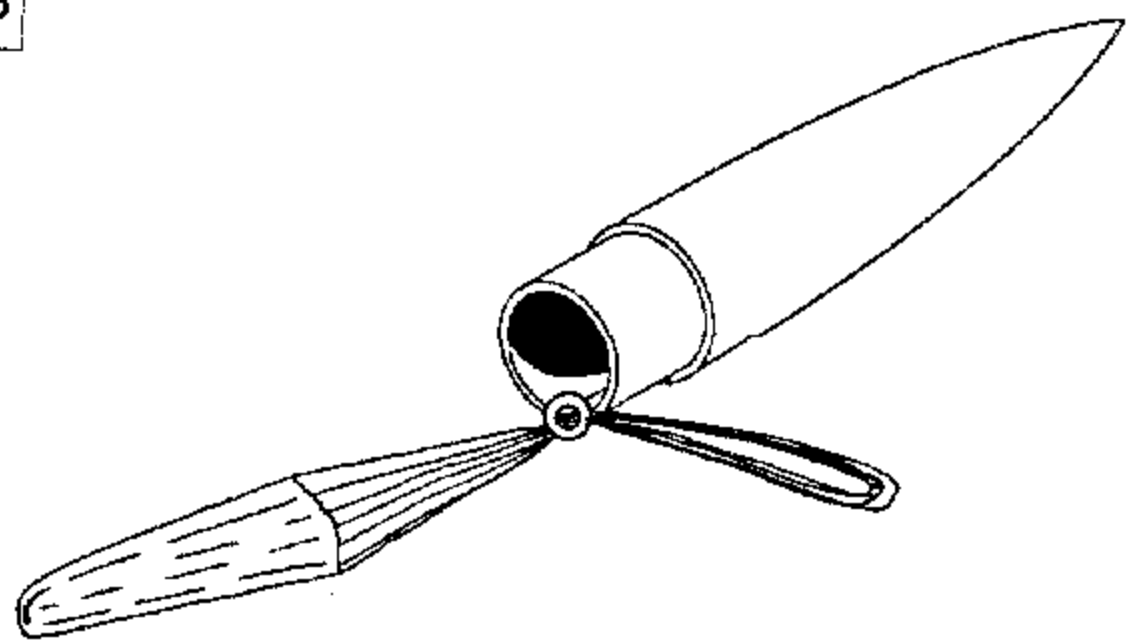

Thread the shroud line loops through the screw eye.

A

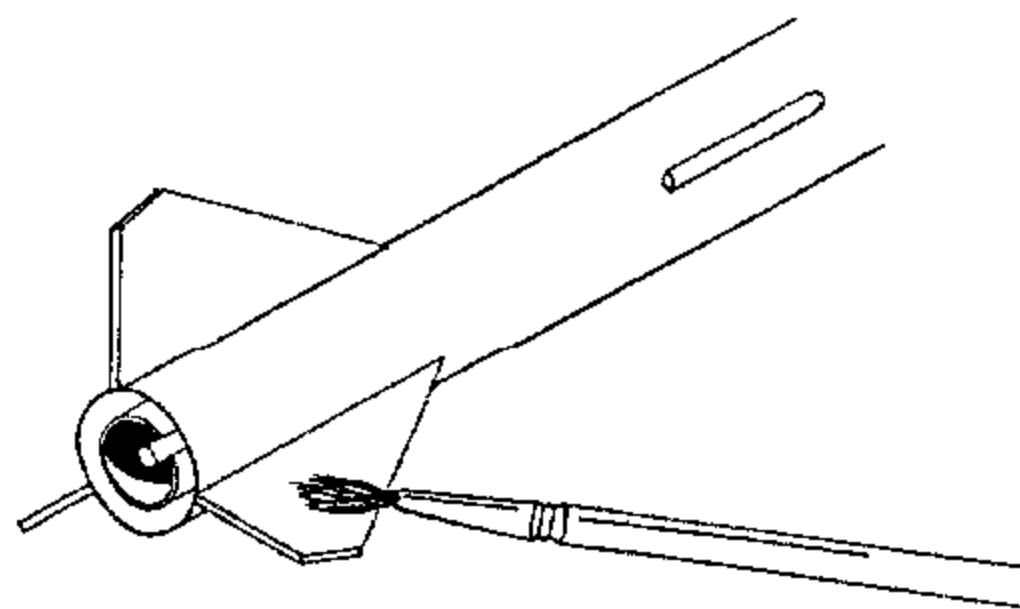

Apply a thin coat of Gesso (available at art supply stores) or sanding sealer to the fins. Apply 3 coats, sanding between each coat. This seals the balsa and makes your model look better.

14

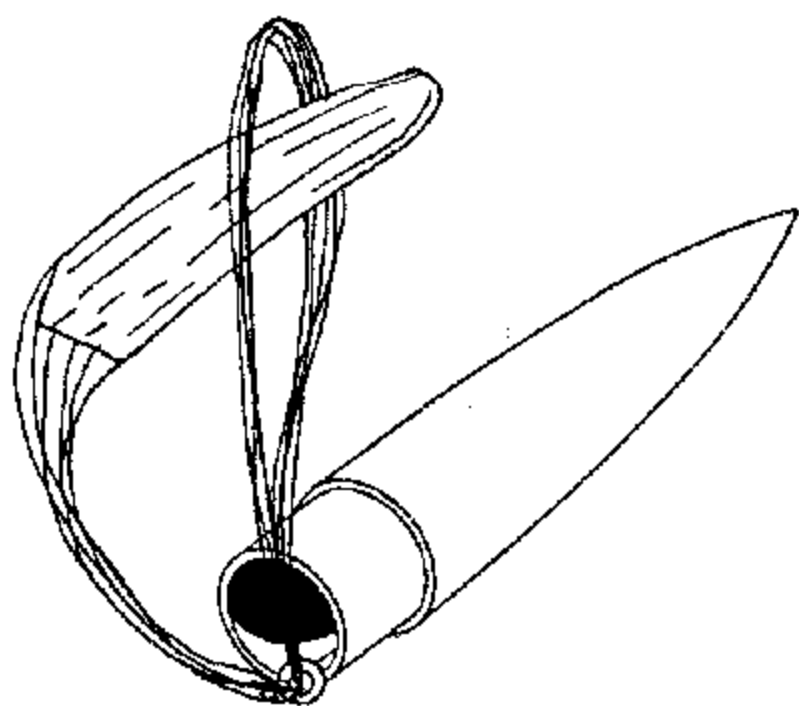

Take the loop ends and pass the parachute through. Pull the parachute tight.

B

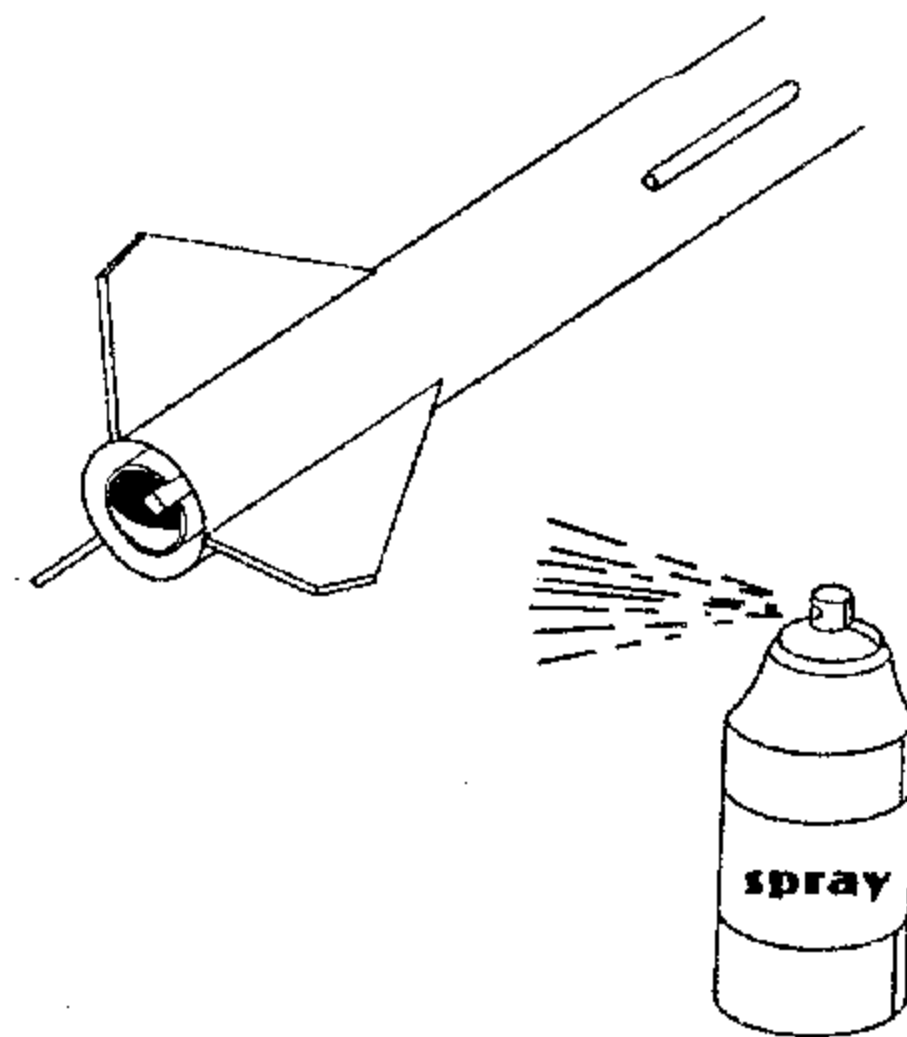

Spray the model with enamel spray.

15

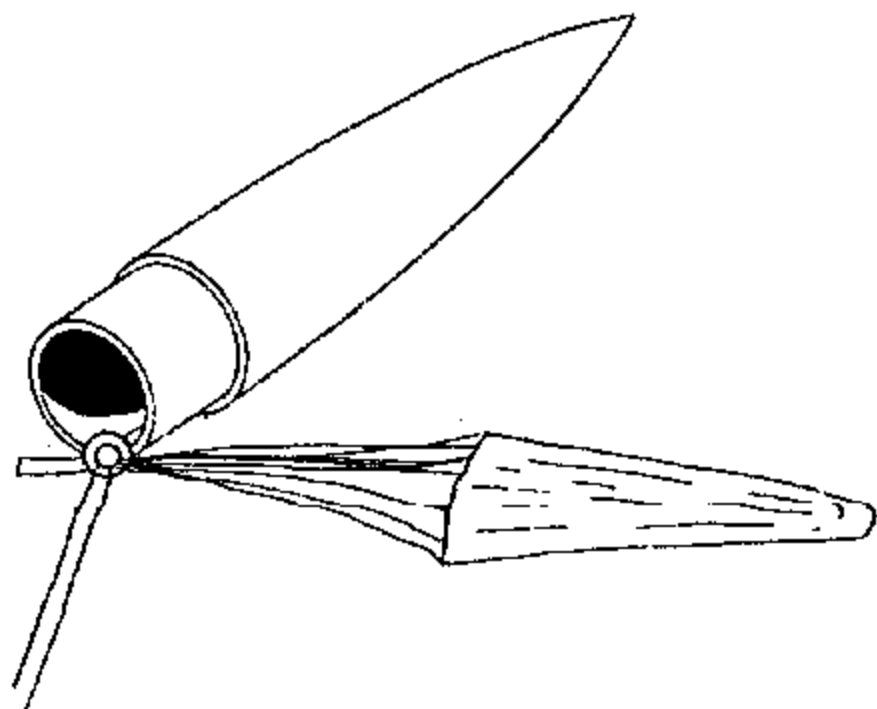

Tie the end of the shock cord to the screw eye.

C

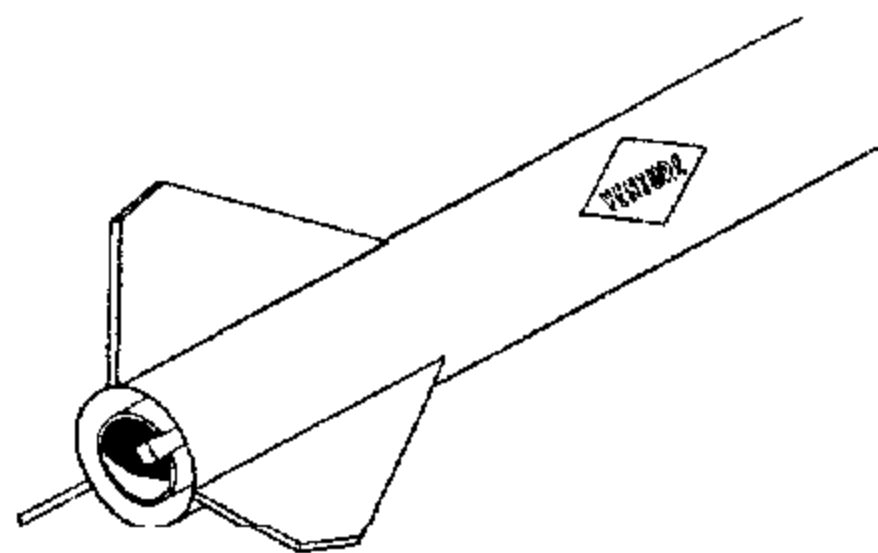

Cut out the decals and dip them in water for 30 seconds. Slide the decal off the backing and onto the model. Once the decals are in position, let them dry overnight.