



Estes Industries
1295 H Street
Penrose, CO 81240

(9-97) 84124
EST 1821



TM & © 1997 Lucasfilm Ltd. All rights reserved. Used under authorization.

The World Leader in Model Rocketry

© Copyright Centuri Corp. All Rights Reserved.

Y-wing Starfighter

READY BUILT FLYING MODEL ROCKET INSTRUCTIONS

1.

A. Form a loop with the shroud lines.

B. Lay shock cord over loop.

C. Pass parachute through loop.

D. Position loop about 1" (2.5 cm) back from the nose cone and pull tight.

2. PACKING PARACHUTE FOR FLIGHT

A. Insert three squares of loosely crumpled recovery wadding. **IMPORTANT:** Recovery wadding must be in place and slide easily for rocket to work properly.

B. Spike parachute.

C. Fold

D. Roll

E. Wrap lines loosely around 'chute. Insert parachute into rocket. Parachute should slide easily into body tube. If fit is too tight, unfold and repack again.

F. Slide shock cord and nose cone into place.

3. ENGINE PREPARATION

A. Separate igniter and igniter plug.

B. Drop in igniter. **TIP MUST TOUCH PROPELLANT**

C. Insert igniter plug.

D. Firmly push all the way in.

E. Bend igniter wires back.

F. Slide engine into rear of rocket.

WARNING - FLAMMABLE

BEFORE PROCEEDING, READ INSTRUCTIONS AND NAR SAFETY CODE INCLUDED WITH ENGINES.

PREPARE YOUR ENGINE **ONLY** WHEN YOU ARE **OUTSIDE** AT THE LAUNCH SITE PREPARING TO LAUNCH!

If you do not use your prepared engine, remove the igniter before storing your engine.

LAUNCH SUPPLIES

To launch your Y-wing Starfighter, you will need the following:

- Launch Pad (Estes Porta-Pad® II)
- Launch Controller (Estes Electron Beam®)
- Recommended Estes Engines: B4-2, B6-2 (first flight), C5-3, C6-3
- Recovery Wadding (EST 302274)
- Igniters and Igniter Plugs (Included with Estes engines.) U.S. Patent No. 5,509,354

Use only Estes products to launch this rocket.

TIPS FOR FLYING YOUR ROCKET

- Choose a large field away from power lines, buildings, tall trees, and low flying aircraft. Try to find a field at least 250 feet (76 meters) square. The larger the launch area, the better your chance of recovering your rocket.
- Launch area must be free of dry weeds and brown grass.
- Launch only during calm weather with little or no wind and good visibility.
- Don't leave parachute packed more than a minute or so before launch during cold weather (colder than 40° Fahrenheit [4° Celsius]). Parachute may be dusted with talcum or baby powder to avoid sticking.
- Always follow the National Association of Rocketry (NAR) MODEL ROCKETRY SAFETY CODE while participating in any model rocketry activities. The safety code is enclosed with this kit.

PROJECTED ALTITUDES

| ENGINE | FEET | METERS |
|--------|------|--------|
| B4-2 | 125 | 38 |
| B6-2 | 135 | 41 |
| C5-3 | 320 | 98 |
| C6-3 | 300 | 91 |

COUNTDOWN AND LAUNCH

- 10...** Safety key must not be in launch controller. The safety cap with safety key attached should already be on the launch rod.

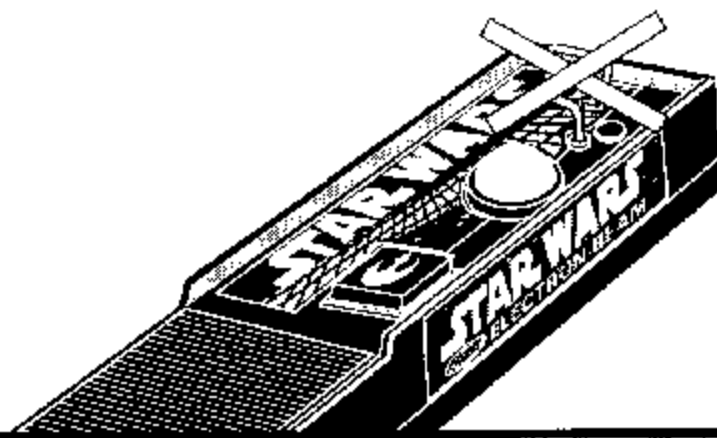

- 9...** Remove safety cap from launch rod, slide launch lugs over rod. Make sure rocket slides freely and micro-clips are clean for good electrical contact.

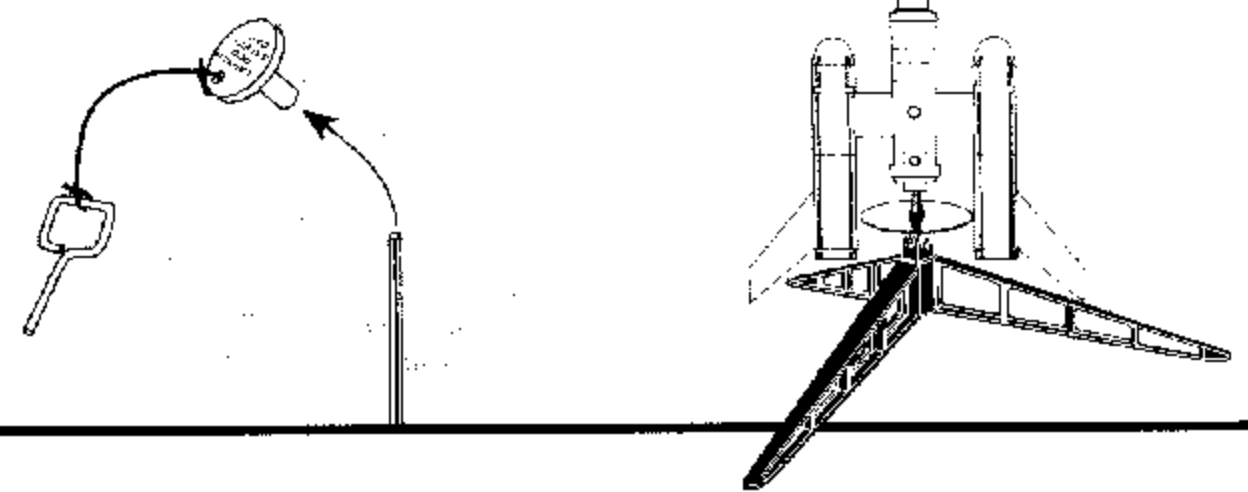

- 8...** Attach micro-clips to the igniter wires. Arrange the micro-clips so they do not touch each other or the metal blast deflector. Attach micro-clips as close to protective tape on igniter as possible.

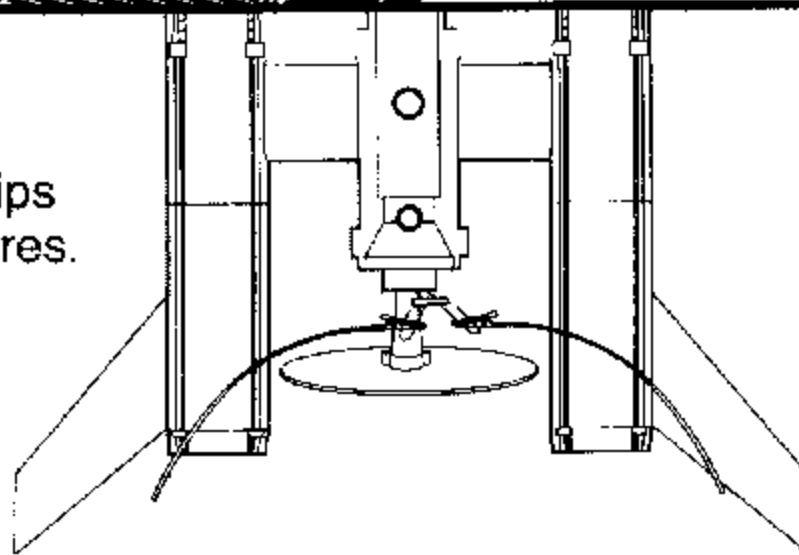

- 7...** Move everyone back from your rocket as far as launch wire will permit (at least 15 feet - 5 meters).

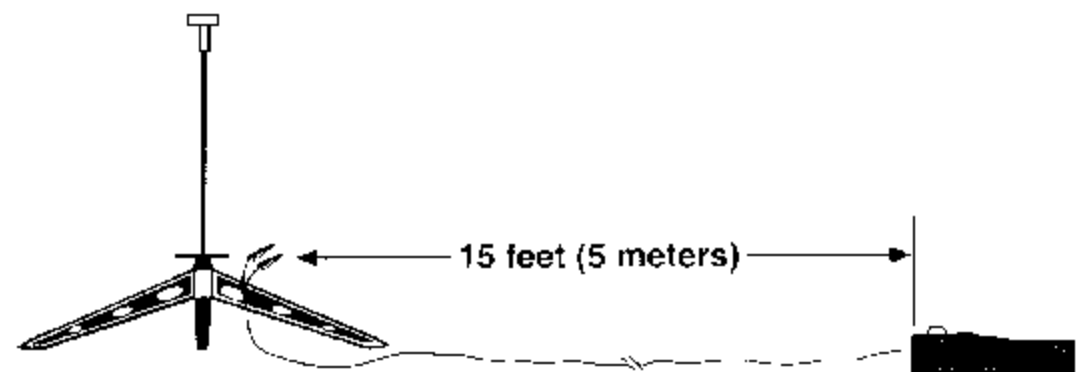

- 6...** Insert safety key to arm the launch controller.

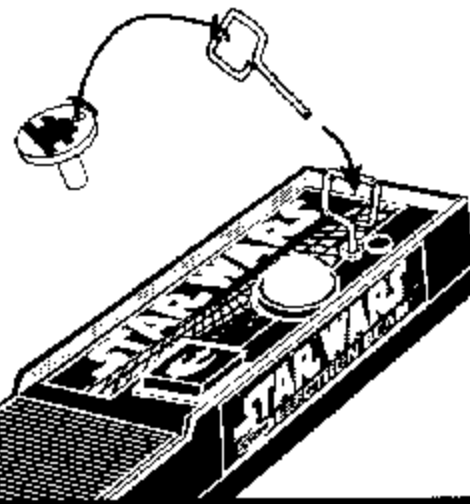

- 5...** Start audible countdown.

4...3...2...1.....LAUNCH!

Push and hold button until engine ignites. For safety, immediately remove safety key from launch controller and replace safety cap on launch rod.

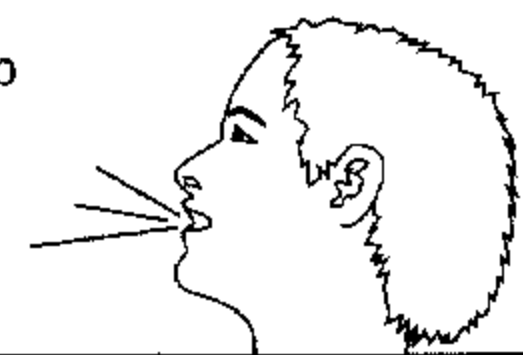

MISFIRES

When an ignition failure occurs, **remove the safety key** from the launch control system and **wait one minute before approaching the rocket**. Remove the expended igniter from the engine and install a new one. Be certain the coated tip is in direct contact with the engine propellant. Broken or chipped coating will not affect the performance of the igniter. Reinstall the igniter plug as illustrated previously. Repeat the countdown and launch procedure.