



A DAMON COMPANY

ESTES INDUSTRIES
295 H STREET
PENROSE, COLORADO 81240 USA

Jupiter-C and Explorer-1

THE FIRST UNITED STATES SATELLITE AND SPACE LAUNCH VEHICLE
#1976

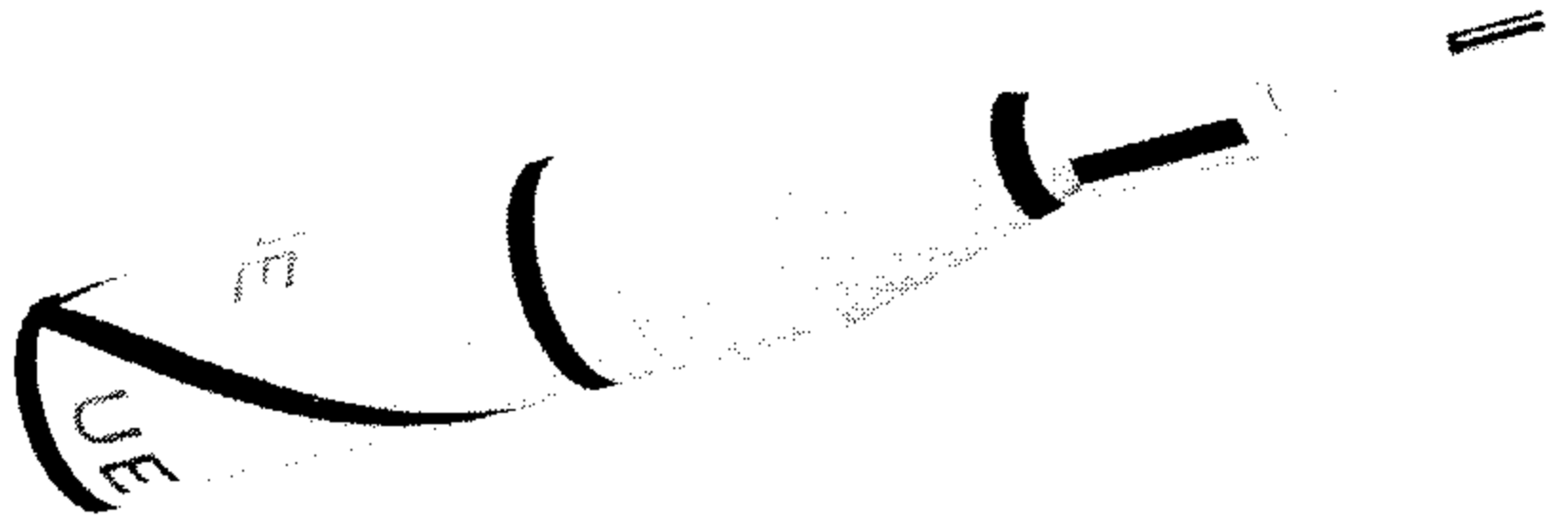

ASSEMBLY TIP

Read all instructions before beginning work on your model. Make sure you have all parts and supplies. Test-fit all parts together before applying any glue. If any parts don't fit properly, sand as required for precision assembly.

PARTS AND SUPPLIES

Locate the parts shown below and lay them out on the table in front of you.

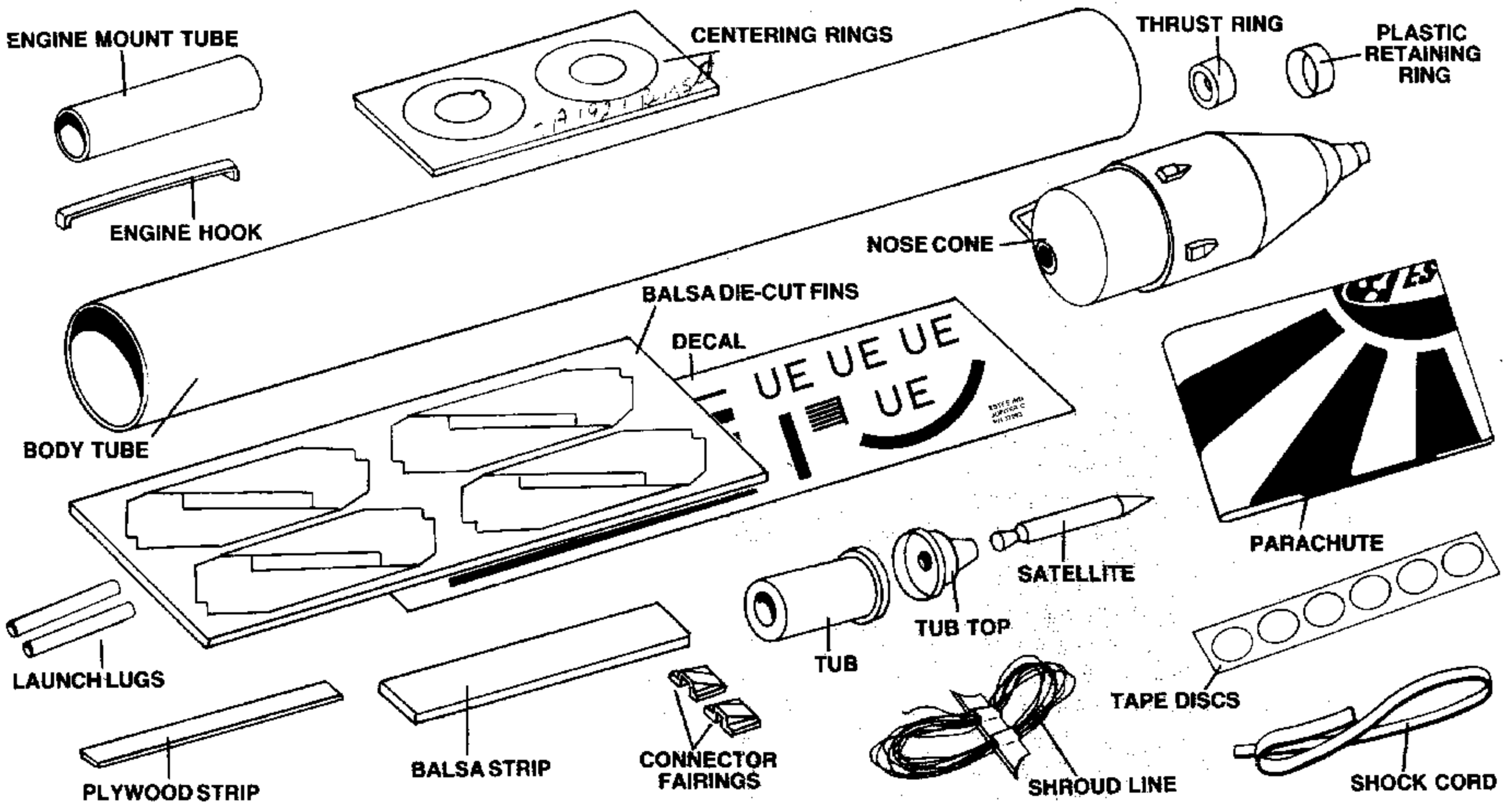

In addition to the parts supplied, you will also need:

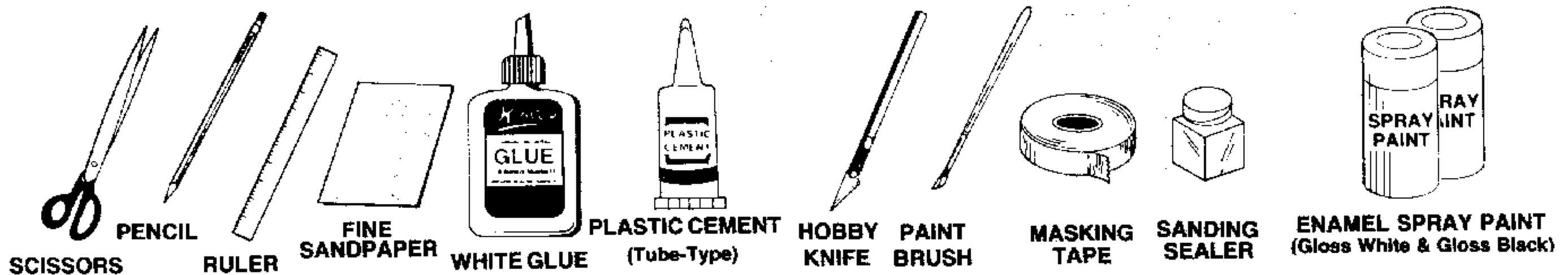

ROCKET ASSEMBLY

NOTE:

Use white glue for all assembly steps except where plastic cement is called for (Steps 15 and 18).

1

- Mark engine mount tube 1 inch and 2 1/2 inches from one end. Cut 1/8 inch wide slit at 2 1/2 inch mark.
- Gently bend the engine hook so it has a very slight upward bow. Don't bend wrong way.
- Apply a light bead of glue between the 1 inch mark and the slit. Insert one end of the engine hook into the slit and press hook into glue. Adjust hook so it is straight with tube.
- Apply a bead of glue around the tube just above the pencil mark. Slide the plastic retaining ring over the top of the tube and down to the mark. Wipe away excess glue.
- Apply a bead of glue around the inside of the top of the tube. Insert the thrust ring and push down until it is against the end of the engine hook.

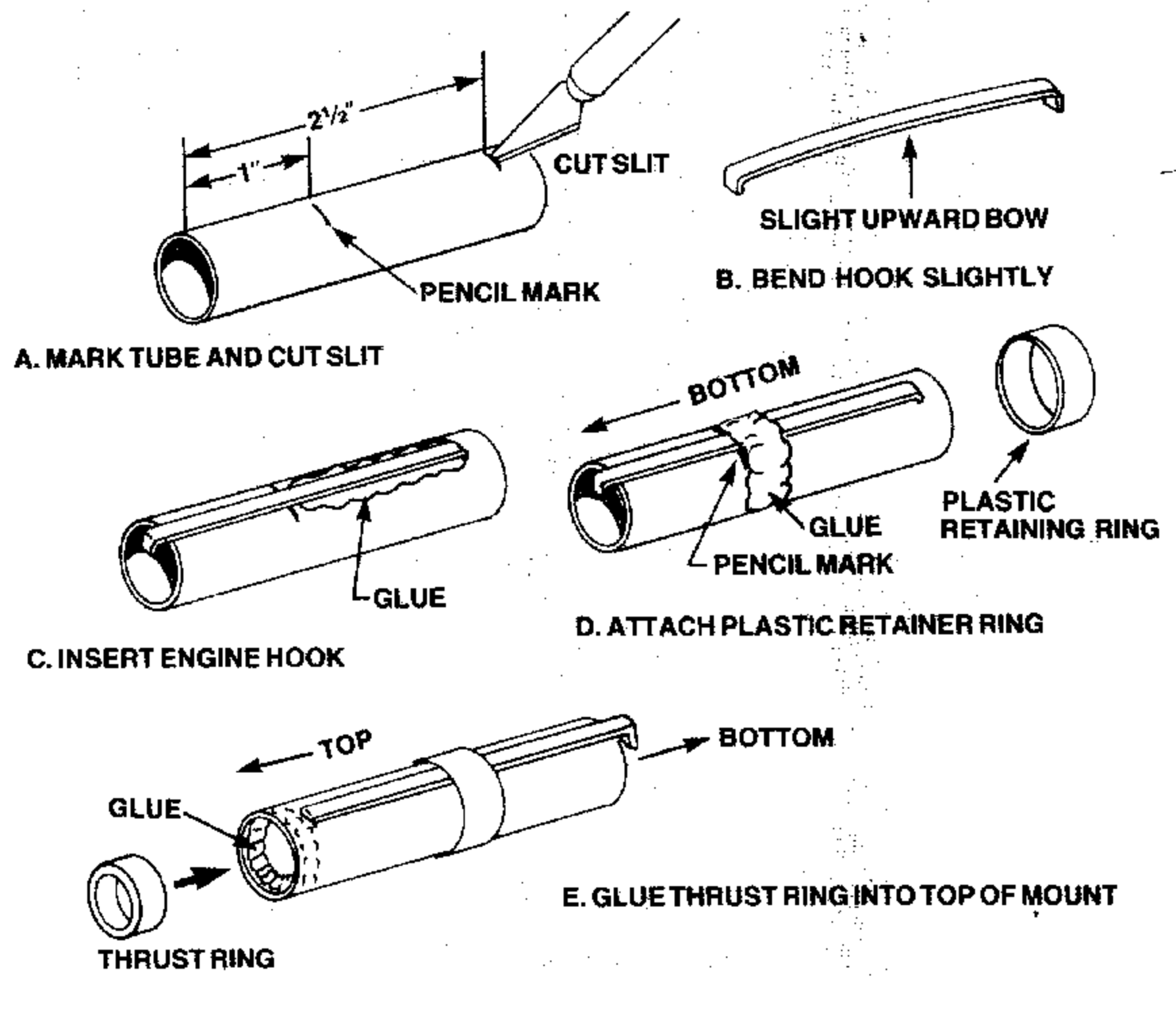

2

- Free the rings from the die-cut card by cutting through the small spaces that hold rings into card.
- Place the notched ring onto the bottom of the tube. The engine hook is centered in the notch. Place the other ring over the top end of the tube. Position the rings so they are 1/16 inch from the ends of the tube. Apply a light bead of glue around the ring/tube joints. Align the rings so they are straight and perpendicular to the tube. Allow glue to dry before proceeding with Part C.
- Apply an additional fillet of glue to both sides of both ring/tube joints for added strength. Lay the engine mount aside for now.

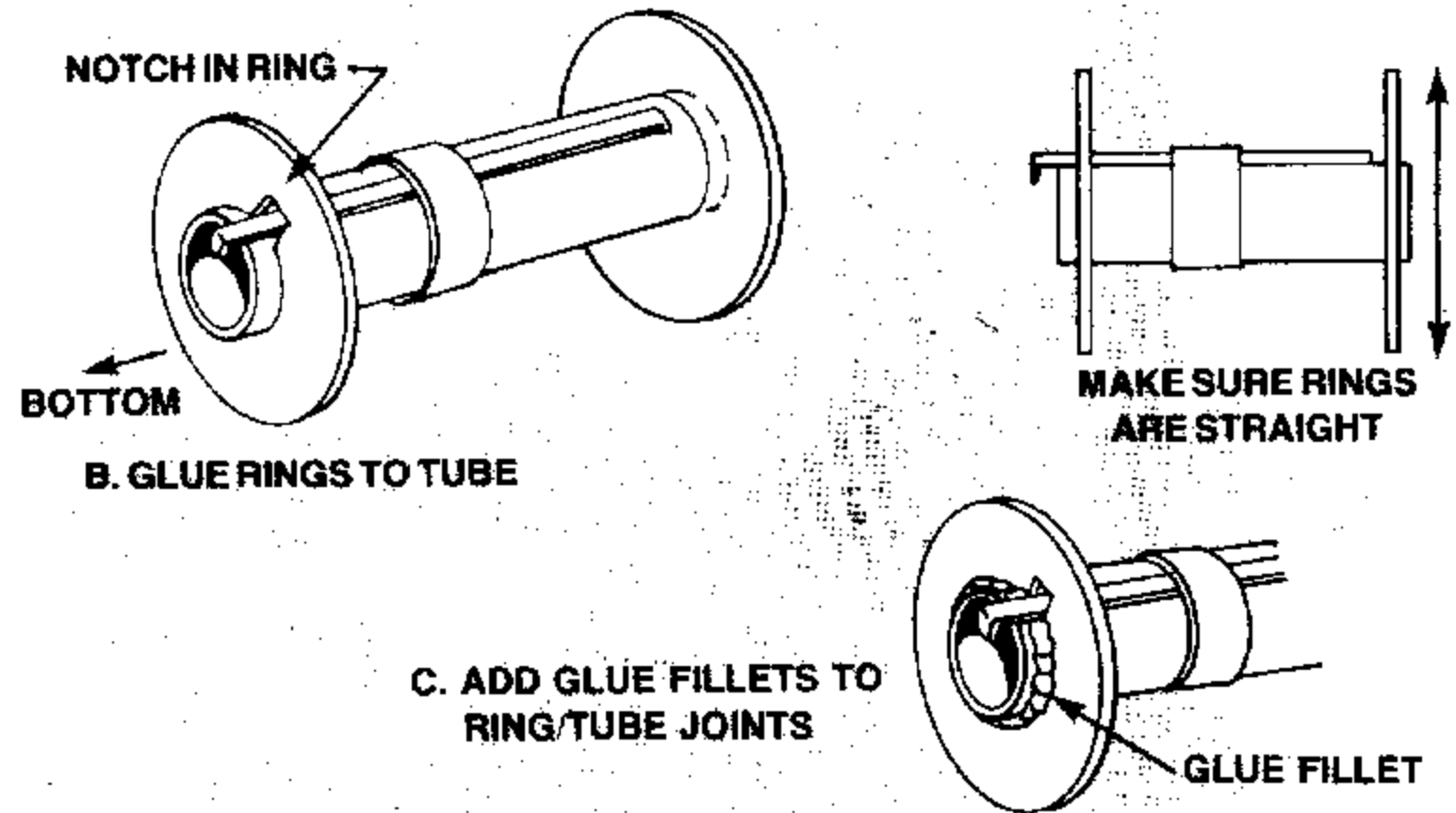

3

Prior to beginning fin assembly, you will need to make a sanding block as shown below. This block will be necessary to achieve a good tapered edge to the fins.

The plan views at right are full size views of a fin unit. You will need to refer to these views in subsequent assembly steps.

MAKE SANDING BLOCK

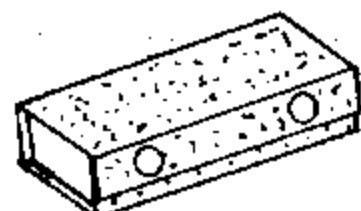
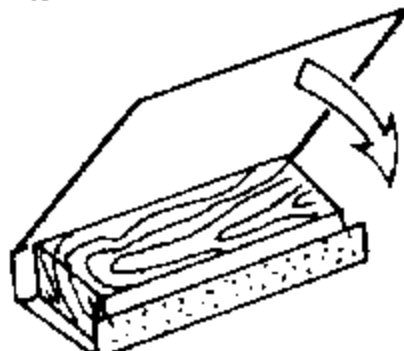

THUMB TACK ENDS TOGETHER

WRAP FINE SANDPAPER TIGHTLY AROUND SMALL WOOD BLOCK

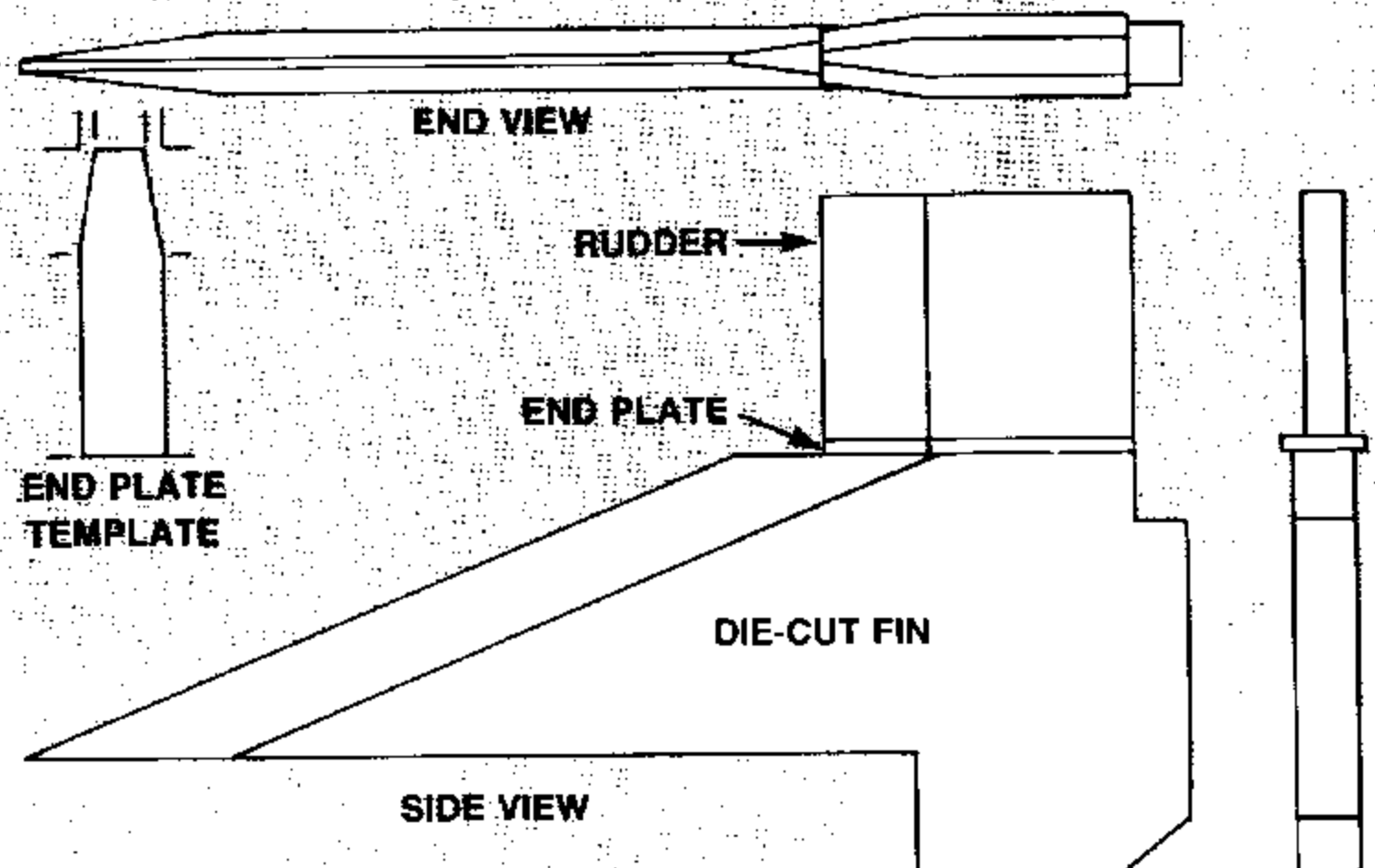

4

- A. Carefully free the fins from the balsa sheet by running the point of a hobby knife along the die-cut lines.
- B. Apply a film of glue on mating sides of two fins and press together. Align fin edges, remove excess glue, set fins on a flat surface and weight with a book or other flat, heavy object. Repeat with the three remaining pairs of fins. Allow glue to dry thoroughly before removing weights (at least 45 minutes).

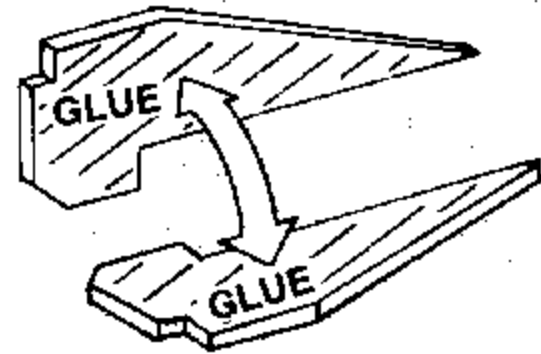

B. GLUE TWO FIN PIECES TOGETHER AND WEIGHT WITH BOOK

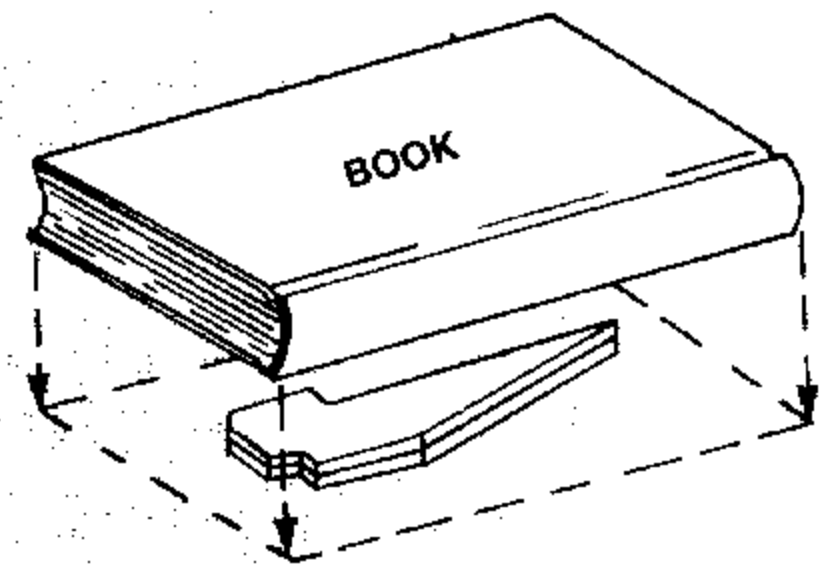

5

- A. Mark one edge of the balsa sheet as shown. Lay the sheet on a flat surface. Holding a pencil at the proper angle, draw a line along the edge of the sheet.
- B. Mark both sides of the sheet 5/16 inch from the same edge on which the center line was drawn. Draw pencil lines along the sides at the 5/16 inch marks.
- C. Using the sanding block, sand a taper to the upper sides of the strip. Leave about 1/32 inch flat at the top of the tapered portion.
- D. Cut four pieces from the sheet. Cut them slightly longer than shown on plan and sand to final length.

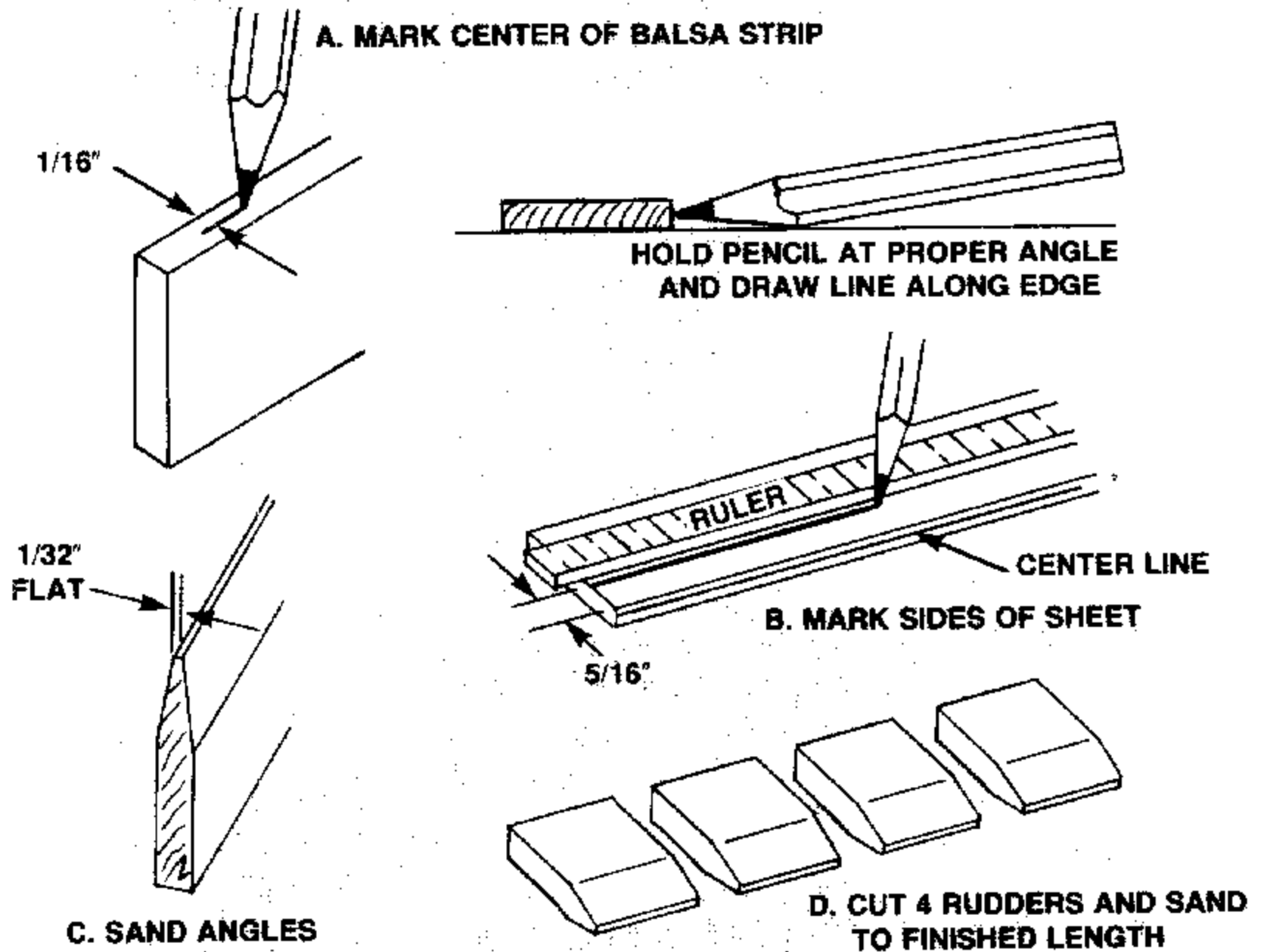

6

- A. Lay the plywood strip over the end plate template. Mark the intersect points of the angled upper portion of the plate.
- B. Sand the angled portion to shape, checking against template as you work.
- C. Lay the plywood on the template, mark the bottom of the end plate, and cut off. Make three more end plates in the same manner.

A. LAY PLYWOOD ON END PLATE TEMPLATE ON PAGE 2. MARK ANGLE POINTS.



B. SAND TAPERED PORTION TO SHAPE



C. CUT OFF BOTTOM

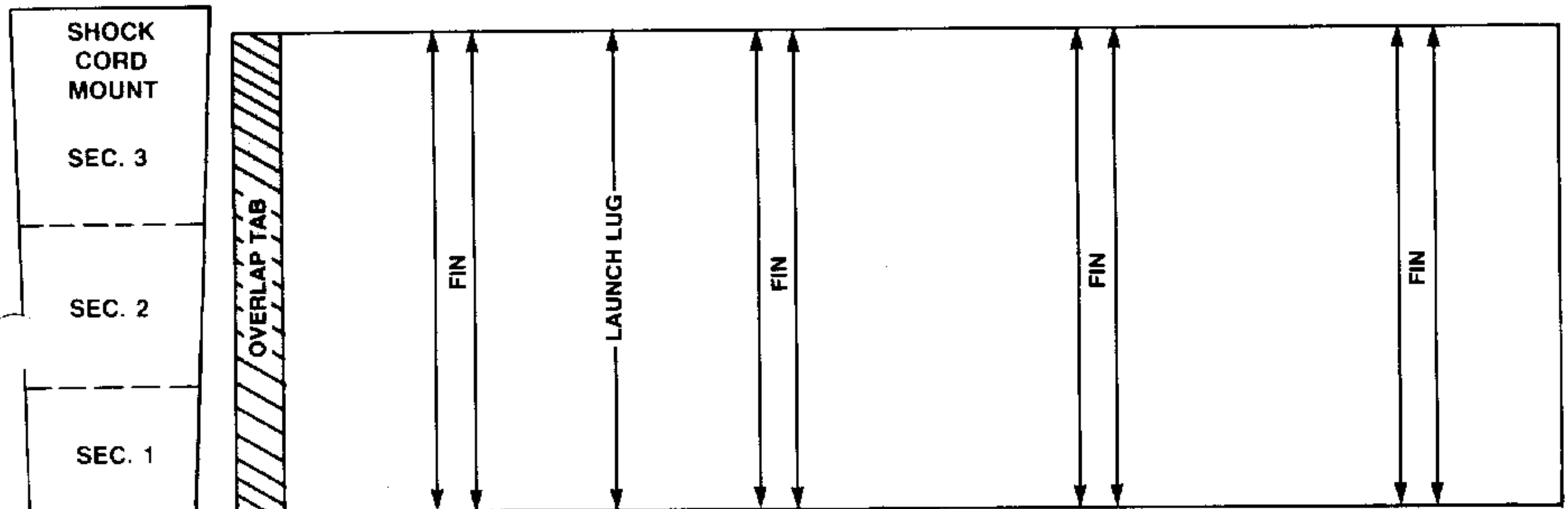

7

NOTE: Do not proceed with this step until the glue on the fins is THOROUGHLY dry.

- A. Draw a pencil line along the angled leading edge of each fin at the joint line between fin halves. Draw lines along both sides of each fin 1/4 inch from the leading edge.
- B. Carefully carve away some of the material from the upper sides. Finish to final taper by sanding. Leave about 1/32 inch of flat area along the leading edge. Sand both sides of each fin and sand all remaining edges square.

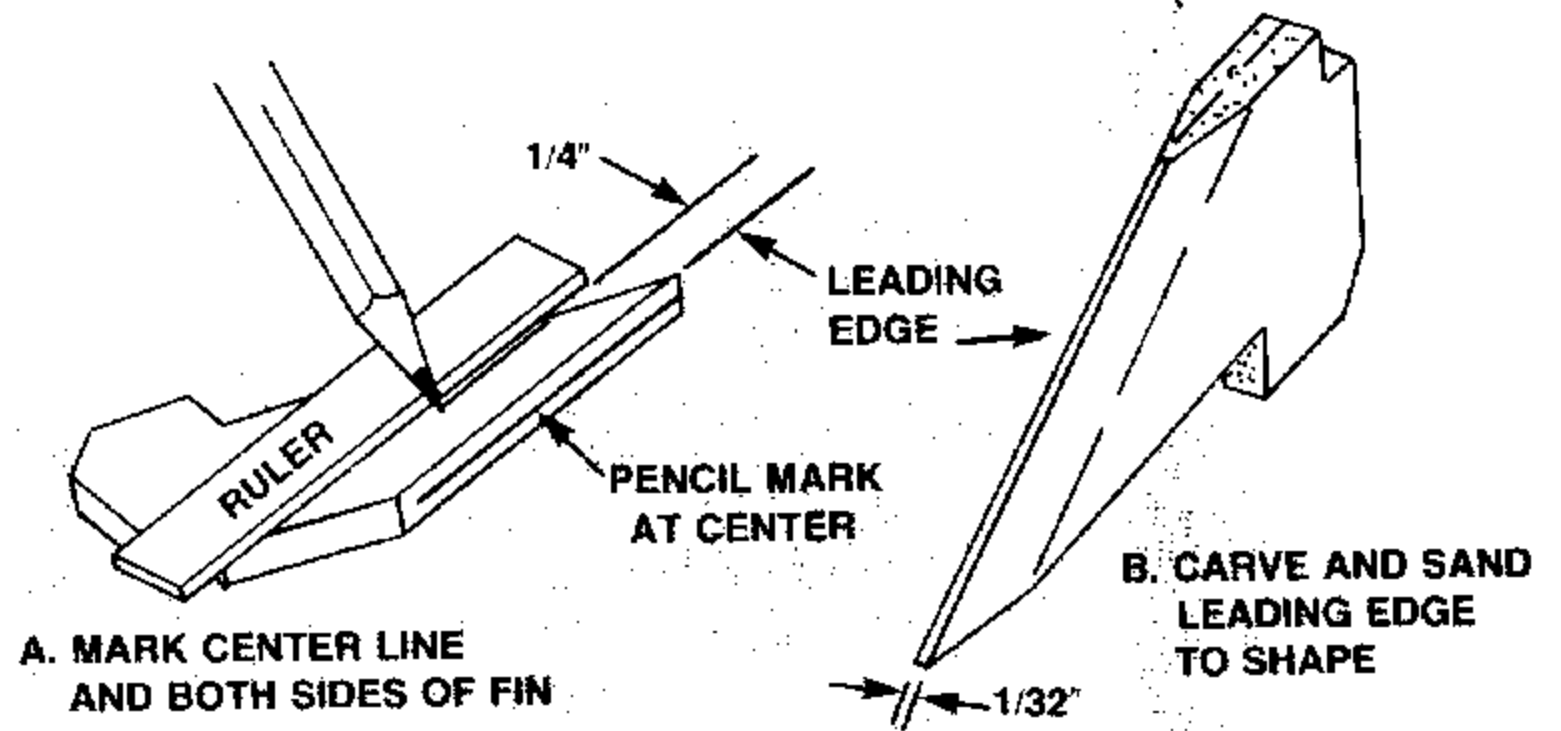

8

NOTE: Use plan view to align parts glued together in this step.

- A. Apply a thin film of glue to one side of an end plate and to the end of a fin. Let parts set for a minute, then press together. Make sure parts are properly aligned before glue sets. Wipe away any excess glue.
- B. Glue a rudder to the end plate using the procedure described above. Glue the remaining fin assemblies together in the same manner.
- C. Place a dab of glue on a piece of scrap paper. Using a needle, pin or piece of fine wire, pick up a small amount of glue and transfer it to one of the glued joints. Pull the "tool" along the joint to produce a small, even fillet. This reinforces the joint and also fills any small holes at the joint lines. Repeat this procedure on all glue joints.

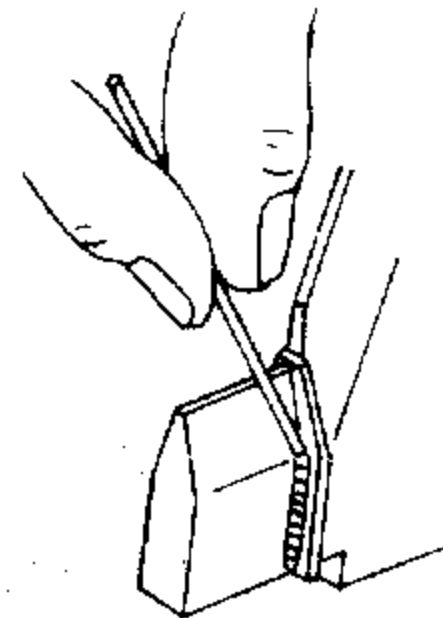
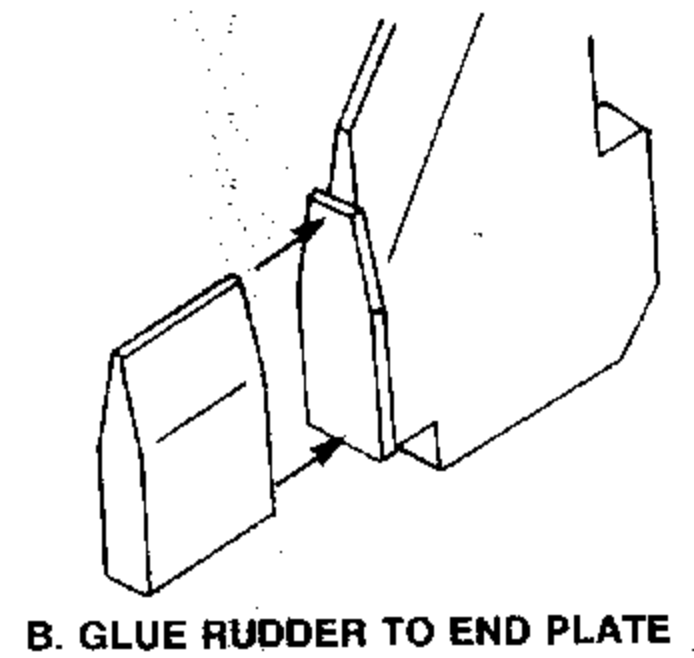
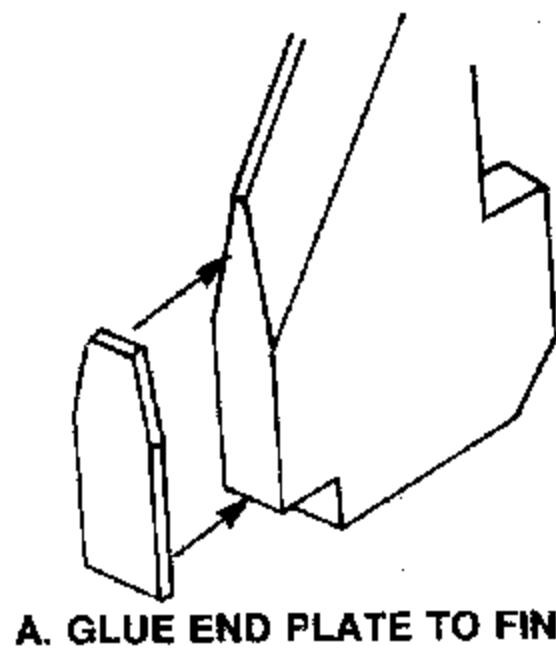

9

Note: Test fit the engine mount into the body tube BEFORE applying any glue. Make sure the mount slides into the body freely. Sand the rings, if necessary, to obtain a good sliding fit. Once glue is applied, it will be too late to make any adjustments.

- A. Using a piece of scrap balsa as an applicator, apply a generous bead of glue around the inside of the body tube about 2 inches from one end.
- B. Insert the front of the engine mount into the tube. Turning the mount at an angle, apply a bead of glue just inside the end of the tube. Slide the mount into the tube until the end of the ring is even with the end of the tube. Place the body in an upright position and support it that way until glue dries.

A. APPLY BEAD OF GLUE 2" INSIDE END OF BODY TUBE

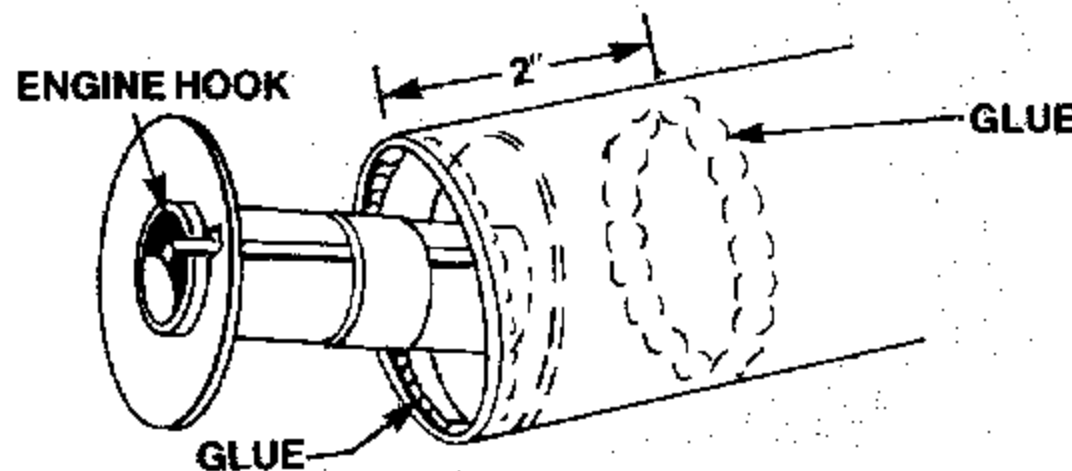

B. INSERT ENGINE MOUNT PART WAY AND APPLY GLUE AROUND REAR OF TUBE

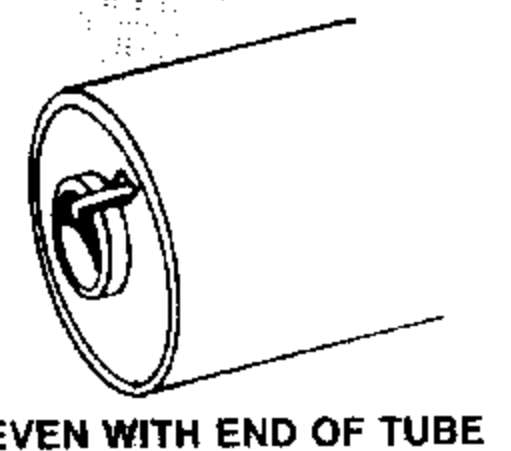

10

- A. Cut the body tube marking guide from the bottom of page 3. Wrap the guide around the end of the body in which the engine mount was glued and tape ends together. Twist the guide so the launch lug line is aligned with the engine hook. Mark the body at each of the arrow points, then remove guide.
- B. Using the lip of a door frame as a guide, draw lines connecting the marks. The fin lines should extend about 3 inches from the rear of the body, and the launch lug line should extend about 10 inches.

LINE UP LAUNCH LUG LINE WITH ENGINE HOOK

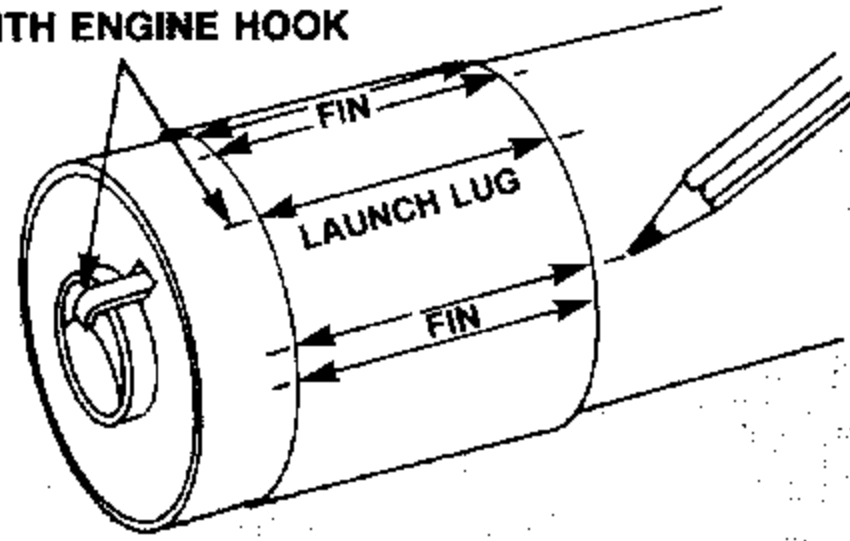

A. MARK BODY TUBE

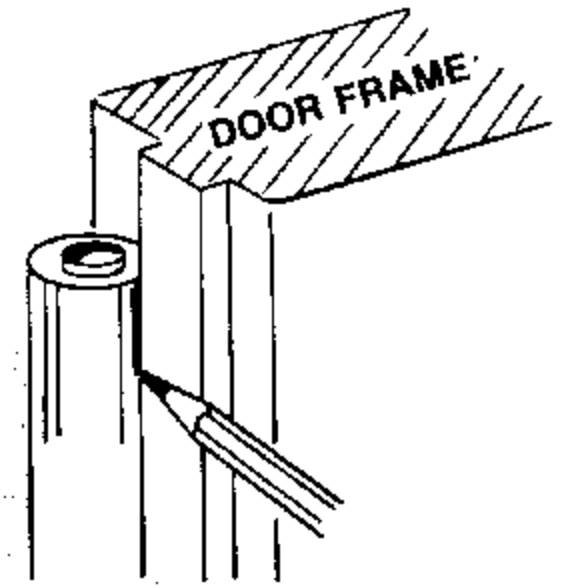

B. DRAW LINES ALONG TUBE. EXTEND LAUNCH LUG LINE 10"

11

- Note: Do not proceed with this step until all glue fillets on the fins are thoroughly dry.
- Apply sanding sealer to all fin surfaces except the edges that glue to the sides and bottom of the body. Allow the sealer to dry, then sand the surfaces. This procedure should be repeated several times until all balsa grain lines are filled and the fins are completely smooth.

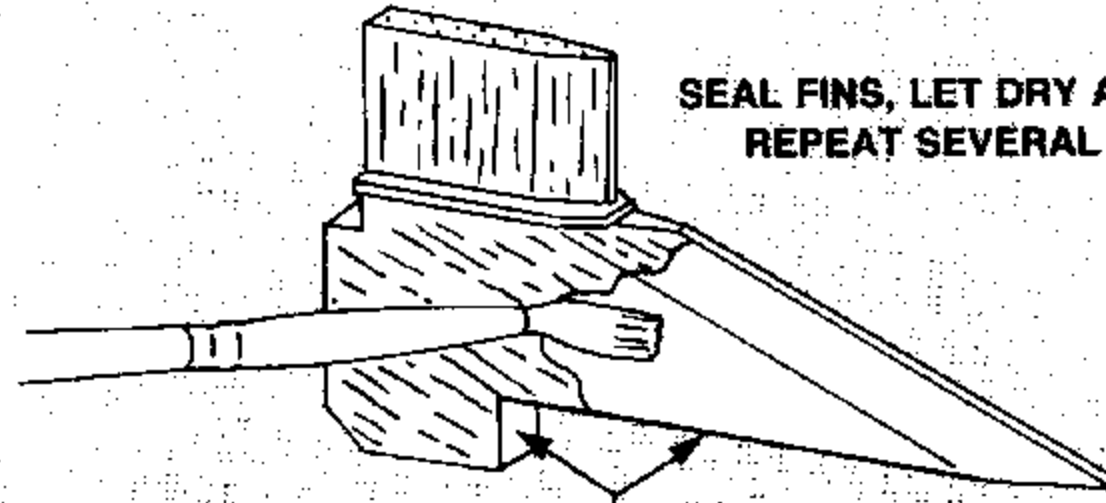

AVOID GETTING SEALER HERE

12

Glue a fin to the body, using the pencil lines to exactly position the fin. Sight from the rear of the body to make sure the fin extends straight from the body. Support the assembly, with the fin pointing straight up, until the glue dries. Next attach a fin to the opposite side of the body. The remaining two fins are glued in place in the same manner.

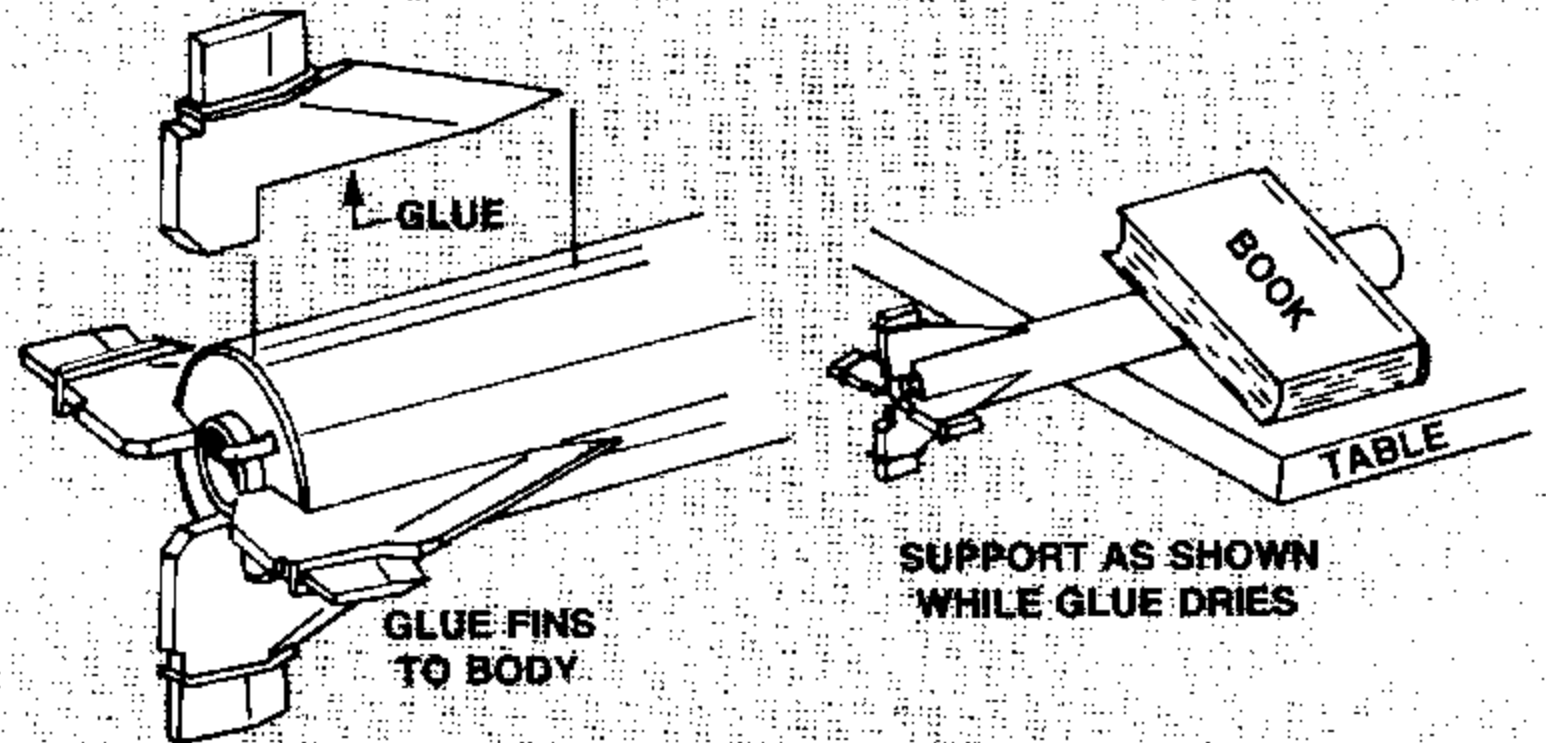

GLUE FINS TO BODY

SUPPORT AS SHOWN WHILE GLUE DRIES

13

Mark the launch lug line at the dimensions indicated and glue the launch lugs in place. If you have a launch pad, insert the launch rod through the lugs and align them before the glue sets. Leave the rod in place until the glue dries. If you do not yet have a launch rod, use a ruler to align one side of the lugs. The lugs must be properly aligned to prevent binding during launch.

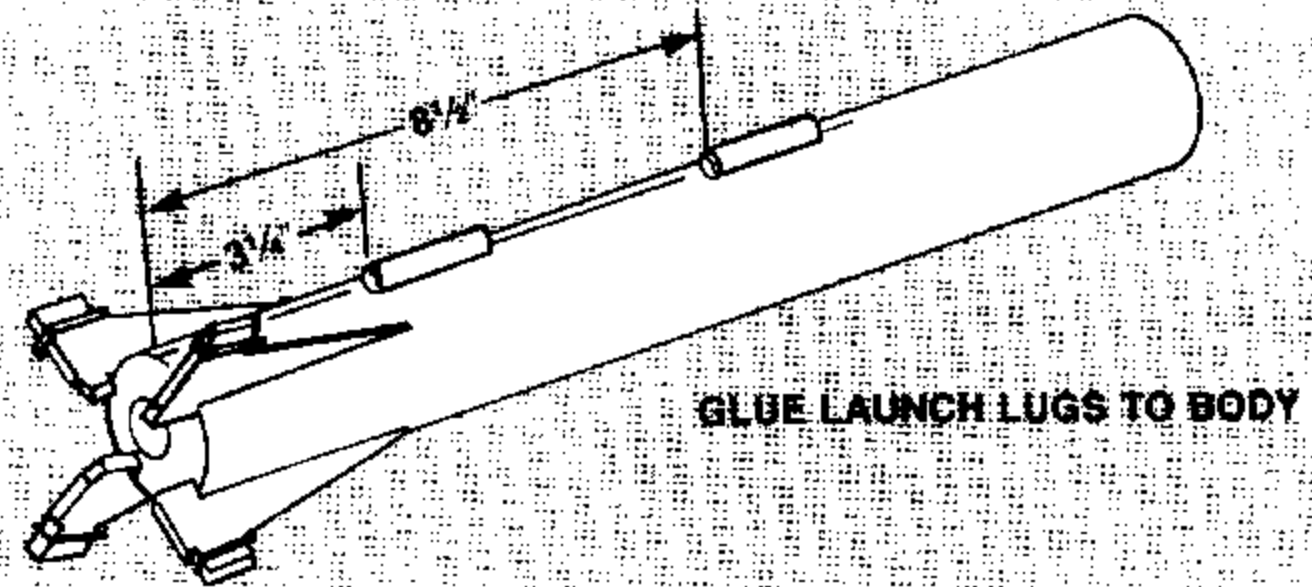

GLUE LAUNCH LUGS TO BODY

14

After the fin/body joints are dry, apply a reinforcing bead of glue to all fin/body joints. Use your finger to smooth the glue into small, even fillets. Wet your finger in water between smoothing operations. Apply a small fillet of glue to both sides of the launch lug/body joints. Support the assembly as shown in Step 12 while the glue dries.

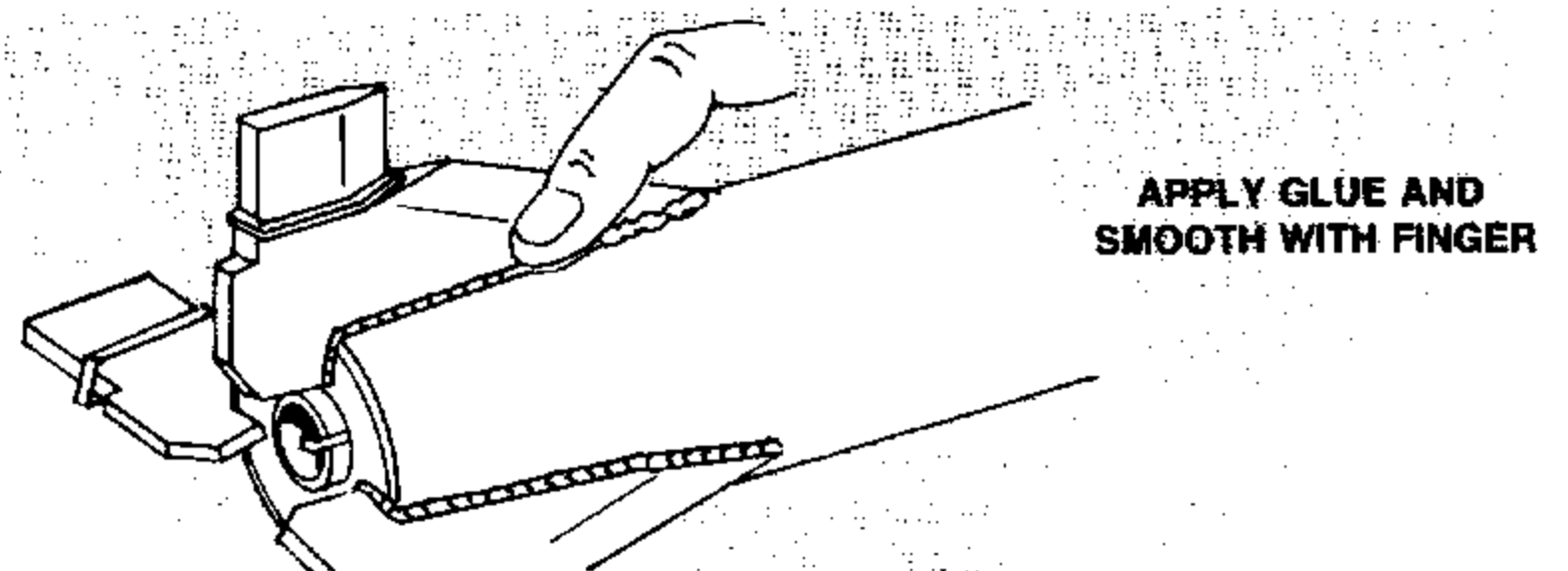

APPLY GLUE AND SMOOTH WITH FINGER

15

NOTE: Use tube-type plastic cement in this step, NOT white glue.

The connector fairings are attached to the body in the positions shown. Lightly sand the body in these areas to provide a better gluing surface. Apply plastic cement to the rear of the flange on each fairing and attach to body. Let the glue dry for 10 minutes, then, using a pin as an applicator, apply more glue up inside the fairings to strengthen the joint.

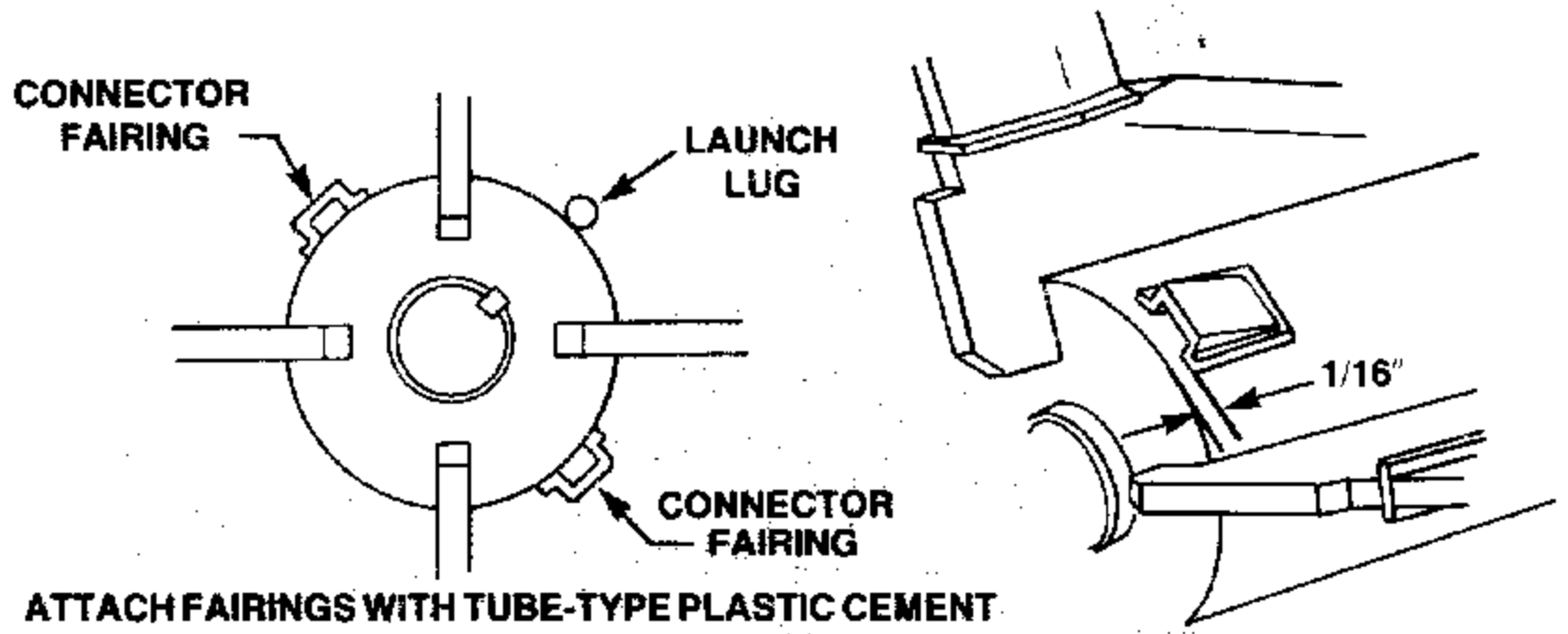

16

- A. Cut shock cord mount from page 3 of the instructions.
- B. Crease on dotted lines by folding. Spread glue on section 1 and lay end of shock cord into glue. Fold over and apply glue to back of first section and exposed part of section 2. Lay shock cord as shown and fold mount over again.
- C. Clamp unit together with fingers until glue sets.

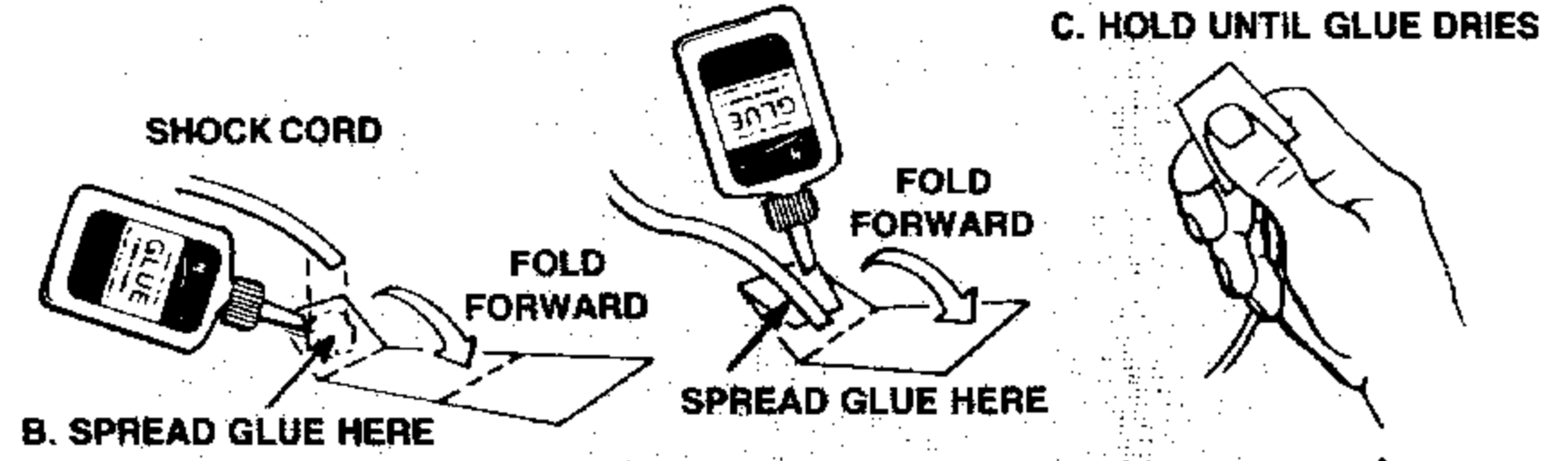

17

Apply a film of glue inside the front of the body at least 1 1/2 inches from the end. The glue area must be at least as large as the shock cord mount. Press the shock cord mount into the glue, molding the mount with your finger to fit the contour of the tube. After the glue is dry, smear a film of glue over the mount and surrounding body area.

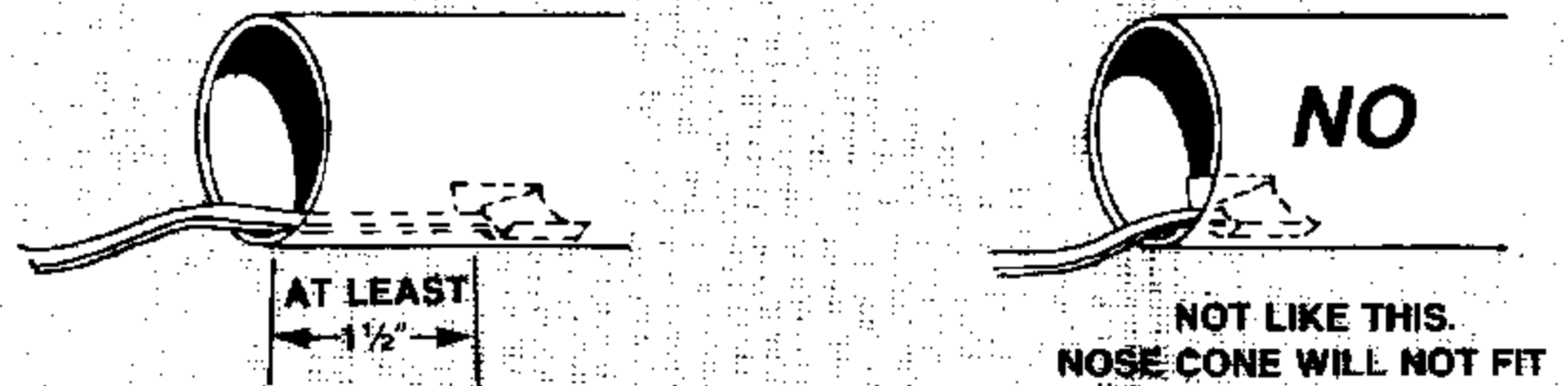

18

Note: Use tube-type plastic cement in this step.

- A. Trim away any excess plastic from the seams in the nose cone and lightly sand the seams until smooth.
- B. Test fit the tub onto the top of the nose cone. If fit is too tight, lightly sand inside of tub rings until tub fits down properly onto nose cone. Apply cement as shown and attach tub.
- C. Apply cement around the inside of the tub and attach tub top.
- D. The satellite may be inserted into the tub top before painting, but DO NOT cement in place. The satellite is for display only and must be removed for actual flight.
- E. In preparation for painting, wipe the plastic parts with a damp cloth.

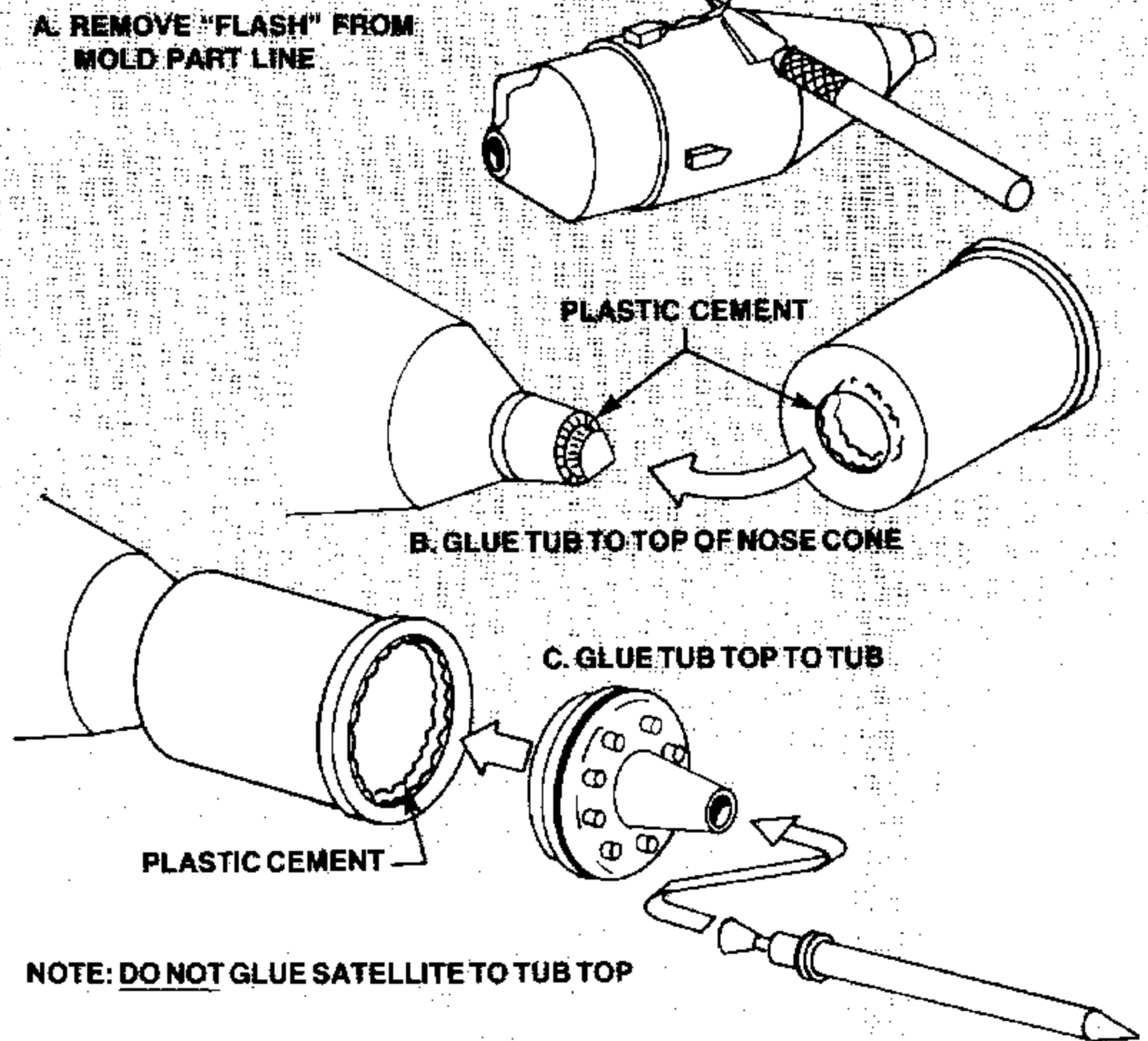

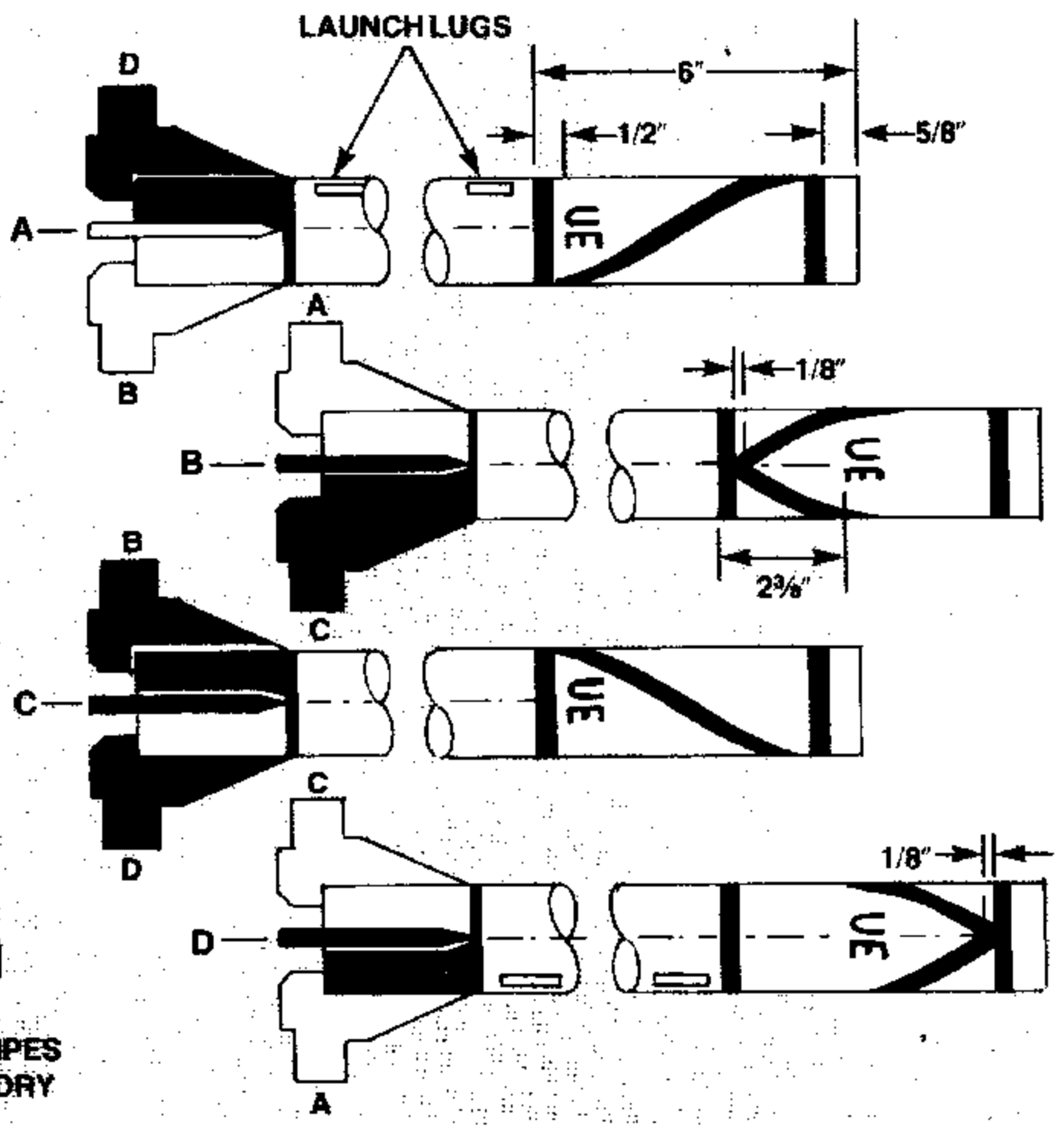
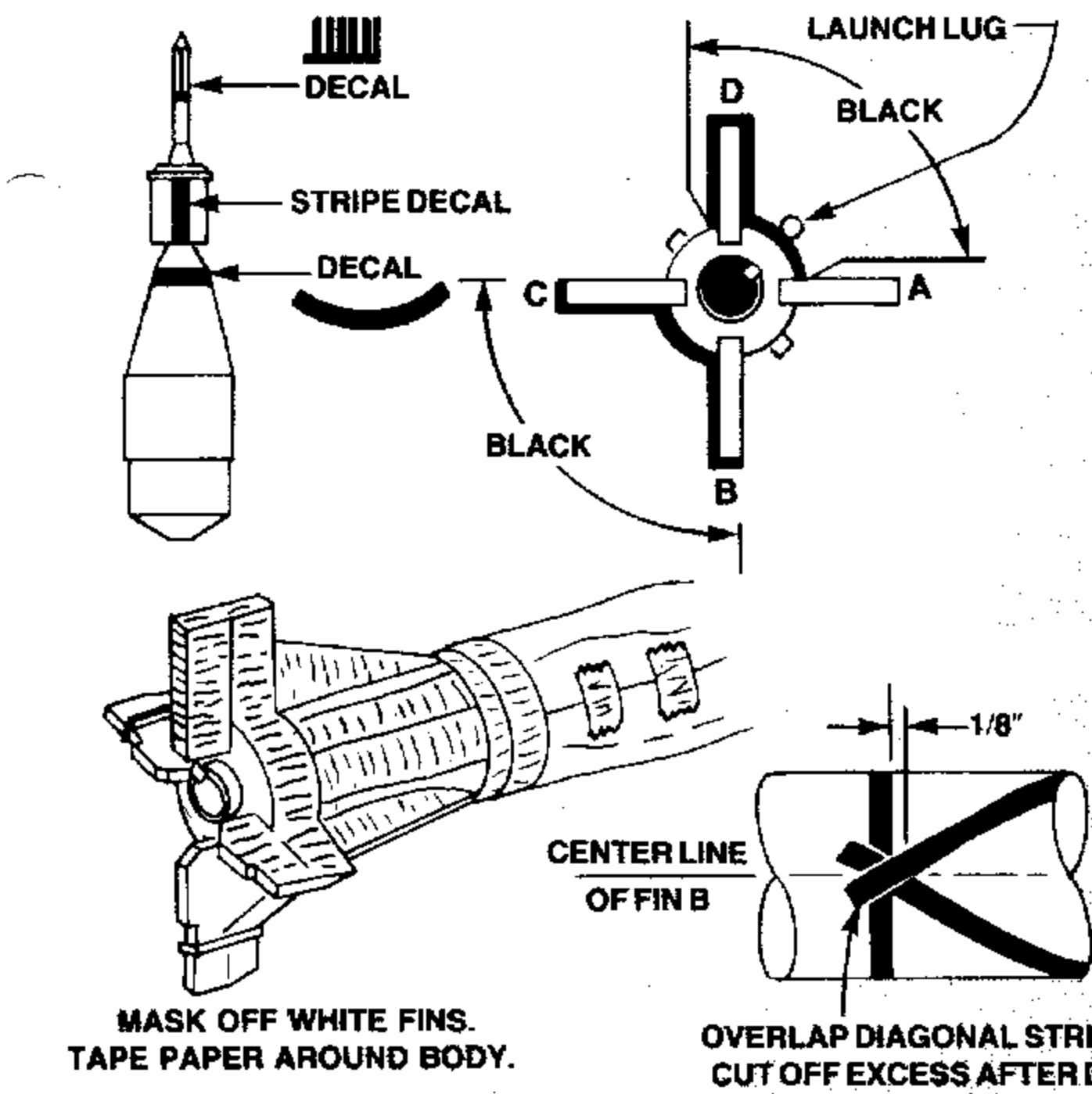

19 PAINTING AND DECALING

Spray paint the rocket and nose assembly white. Allow paint to dry overnight. Study the bottom view and side view drawings so you fully understand which fin and lower body areas are to be painted black. Mask off the fin and adjacent body areas which remain white. Use a piece of paper to mask off the body forward of the fins. Make sure all masked areas are completely sealed with tape. Spray the exposed portions of the lower body black. Allow paint to dry, then remove masking tape and paper.

Decals are cut individually from sheet and soaked in water until they are easy to transfer from backing material (usually 20 to 30 seconds). When decals are transferred to model, they will need to be moved around to be properly aligned.

Applying a little water over the decal with your finger will facilitate this. Apply the long narrow body stripe first. This stripe wraps around the body at the top edge of the fins. Align the ends of the stripe and allow to set for a few minutes before blotting away excess water. Next, apply two of the wide stripes around the body at the dimensions shown. These must be allowed to dry completely before applying diagonal stripes. Note that the diagonal stripe intersections as well as the "UE" decals are centered on fin lines. The diagonal stripes overlap the upper and lower decal bands. Allow stripes to dry, then carefully cut off and lift away excess stripe material. The three decals on the nose portion of the model are applied according to the drawing.

A spray coating of Testor's "Dull-Cote" will protect the decals and provide a realistic flat finish to the model.

20

- A. Cut out the parachute on its edge lines.
- B. Cut three 35 inch lengths of shroud line.
- C. Form small loop in one end of a shroud line and press onto sticky side of a tape disc. Press the disc, sticky side down, onto a corner of the 'chute. Press the disc down firmly onto the 'chute material. Attach the other end of the shroud line to an adjacent corner of the 'chute. Attach the other two shroud lines to the remaining four corners of the 'chute.
- D. Pass the end of the shroud line loops through the eyelet on the nose cone.
- E. Pass the 'chute through the loop ends.
- F. Pull the lines tight against nose cone eyelet.
- G. Tie the free end of the shock cord to the eyelet using a double knot.

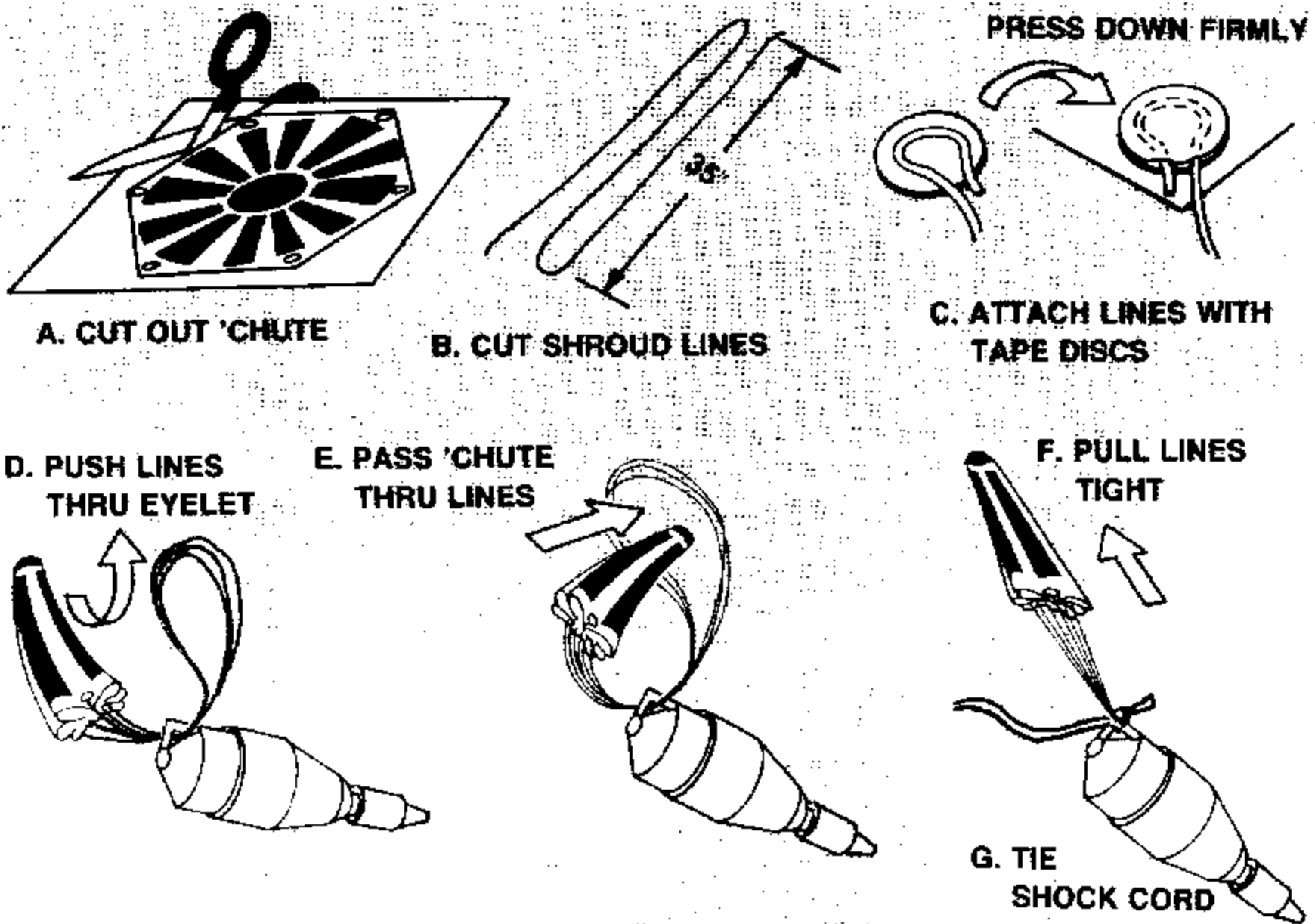

ROCKET PREFLIGHT

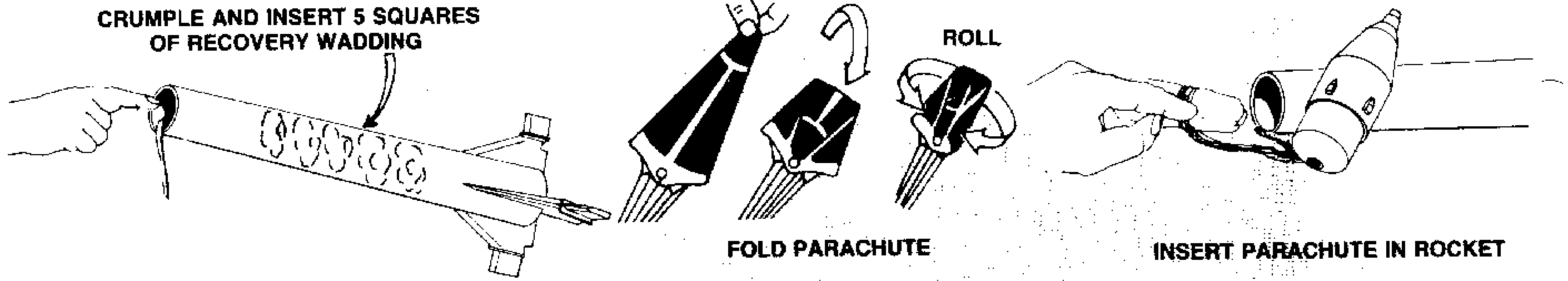

PREPARE ENGINE

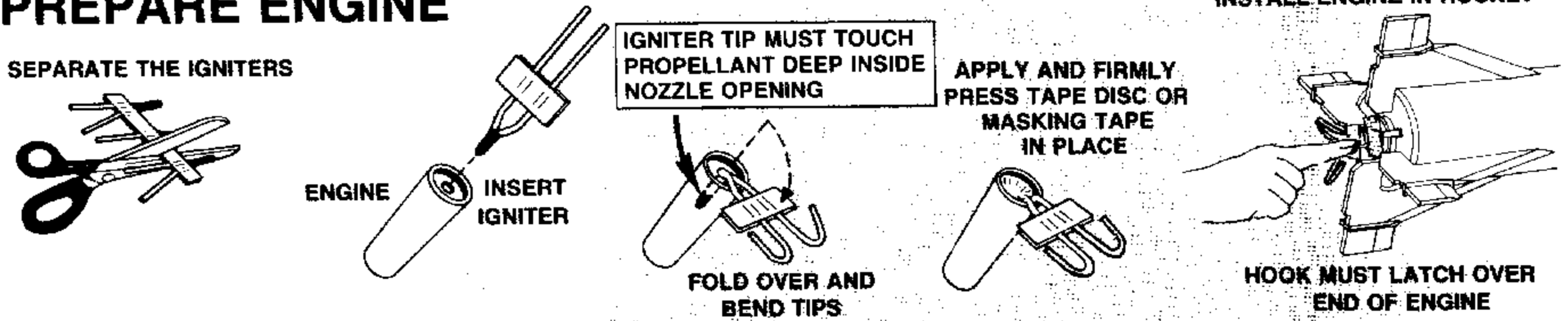

LAUNCH SUPPLIES

To launch your rocket you will need the following items:
 —An Estes model rocket launching system
 —Estes Recovery Wadding (No. 2274)
 —Recommended Engine: C5-3

FLYING YOUR ROCKET

Choose a large field away from power lines, tall trees, and low flying aircraft. Try to find a field at least 250 feet square. The larger the launch area, the better your chance of recovering your rocket. Football fields and playgrounds are great.

Launch area must be free of dry weeds and brown grass.

Launch only during calm weather with little or no wind and good visibility.

Don't leave parachute packed more than a minute or so before launch during cold weather [colder than 40° Fahrenheit (4° Celsius)]

MISFIRES

Failure of the rocket engine to function properly is nearly always caused by a failure to install the igniter correctly. This failure permits the igniter to heat and burn into two pieces without igniting the engine.

FOR YOUR SAFETY AND ENJOYMENT

Always follow the NAR-HIA* MODEL ROCKETRY SAFETY CODE while participating in any model rocketry activities.

*National Association of Rocketry-The Hobby Industry of America
 page 8

COUNTDOWN AND LAUNCH

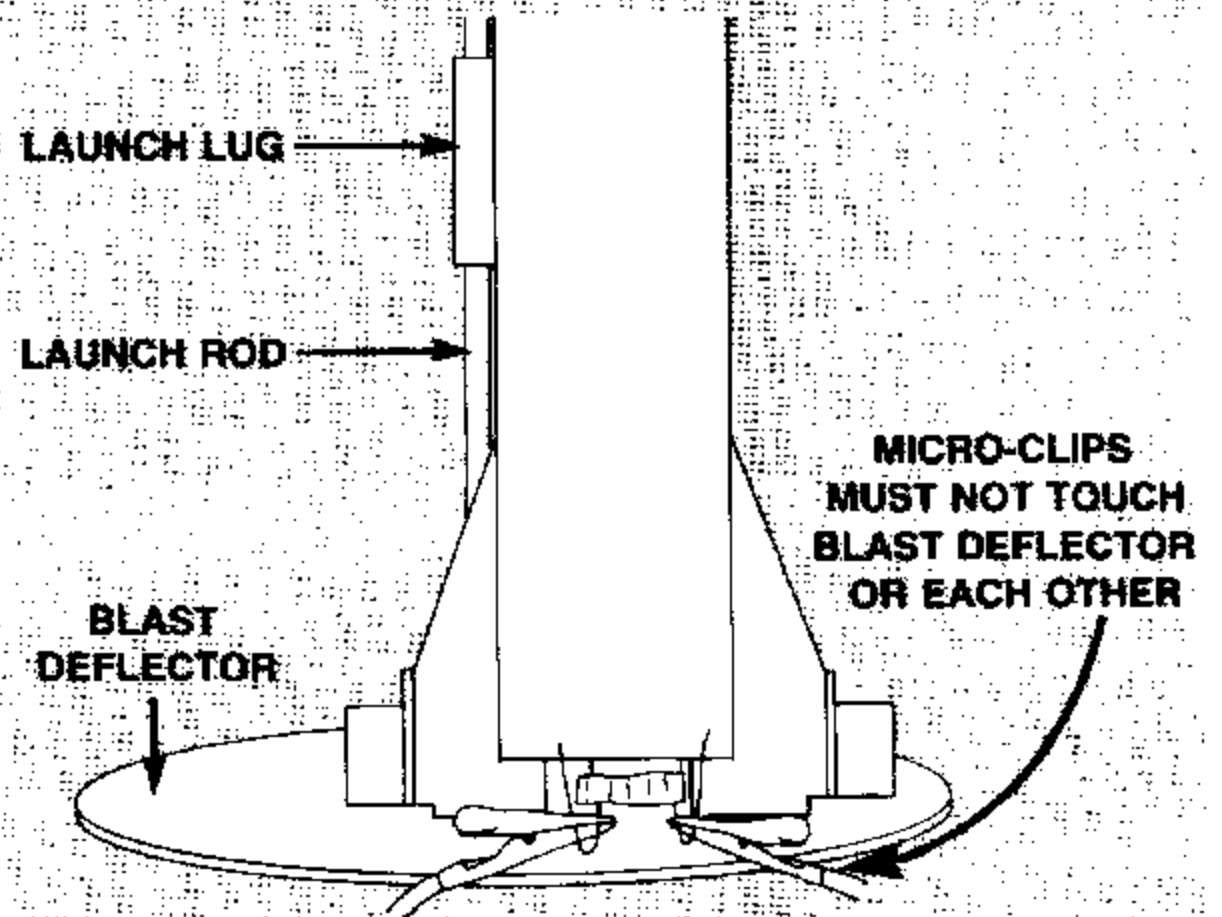

- ⑥ Remove the satellite from the top of the rocket and store it in a safe place.
- ⑤ REMOVE SAFETY KEY to disarm the launch controller.
- ④ Remove safety cap and slide launch lugs over launch rod to place rocket on launch pad. Make sure the rocket slides freely on the launch rod.
- ③ Attach micro-clips to the igniter wires. Arrange the clips so they do not touch each other or the metal blast deflector. Attach clips as close to protective tape on igniter as possible.
- ② Move back from your rocket as far as launch wire will permit (at least 15 feet).
- ① INSERT SAFETY KEY to arm the launch controller.

LAUNCH!!! PUSH AND HOLD LAUNCH BUTTON UNTIL ENGINE IGNITES

Remove safety key—Replace cap on rod.