

See kit  
 Provided 2-6-98



**ESTES INDUSTRIES**  
 PENROSE, CO 81240 USA

# STRIKEFIGHTER™

**FLYING MODEL ROCKET**  
**NO. 2015**

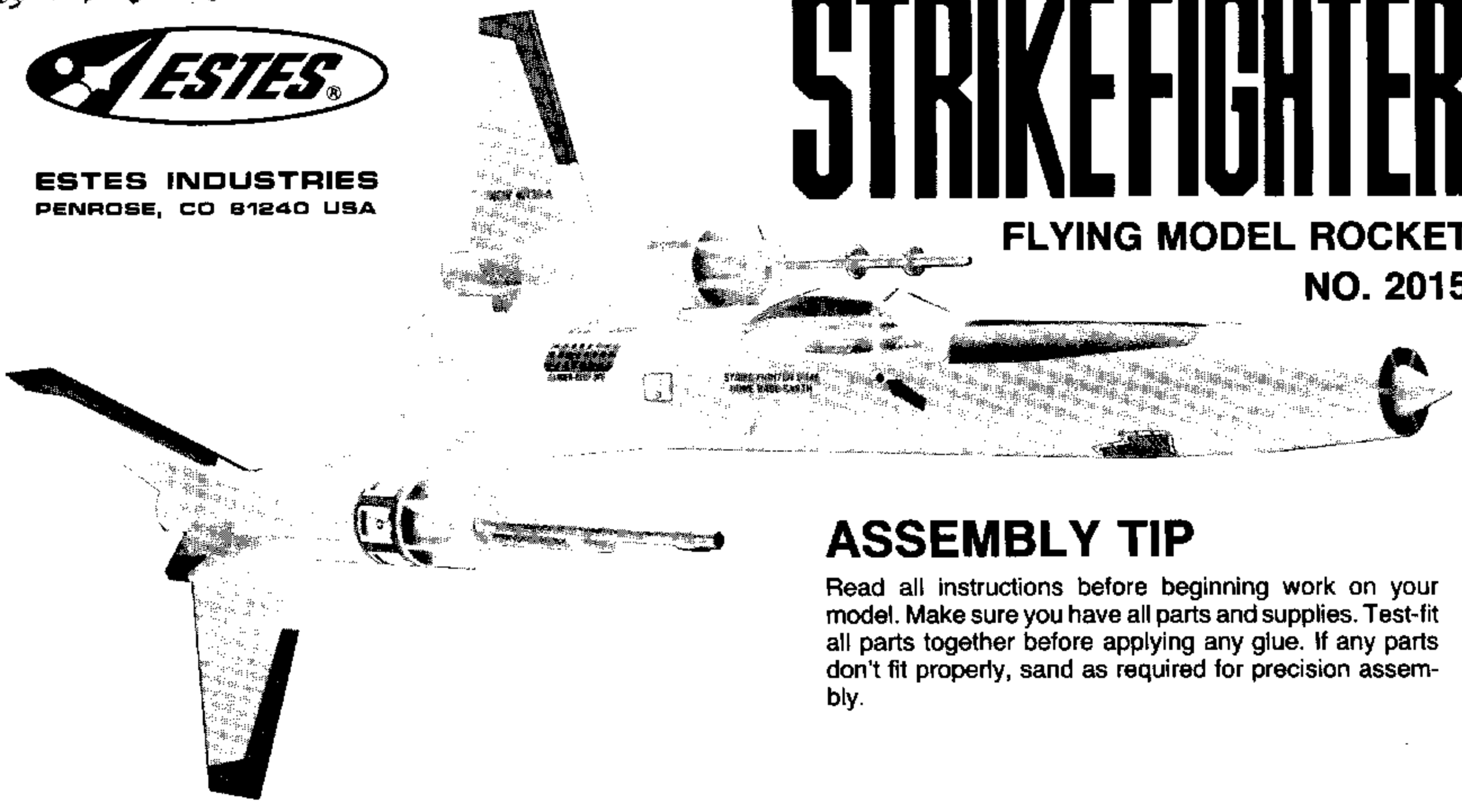

## ASSEMBLY TIP

Read all instructions before beginning work on your model. Make sure you have all parts and supplies. Test-fit all parts together before applying any glue. If any parts don't fit properly, sand as required for precision assembly.

## PARTS AND SUPPLIES

Locate the parts shown and lay them out on the table in front of you.

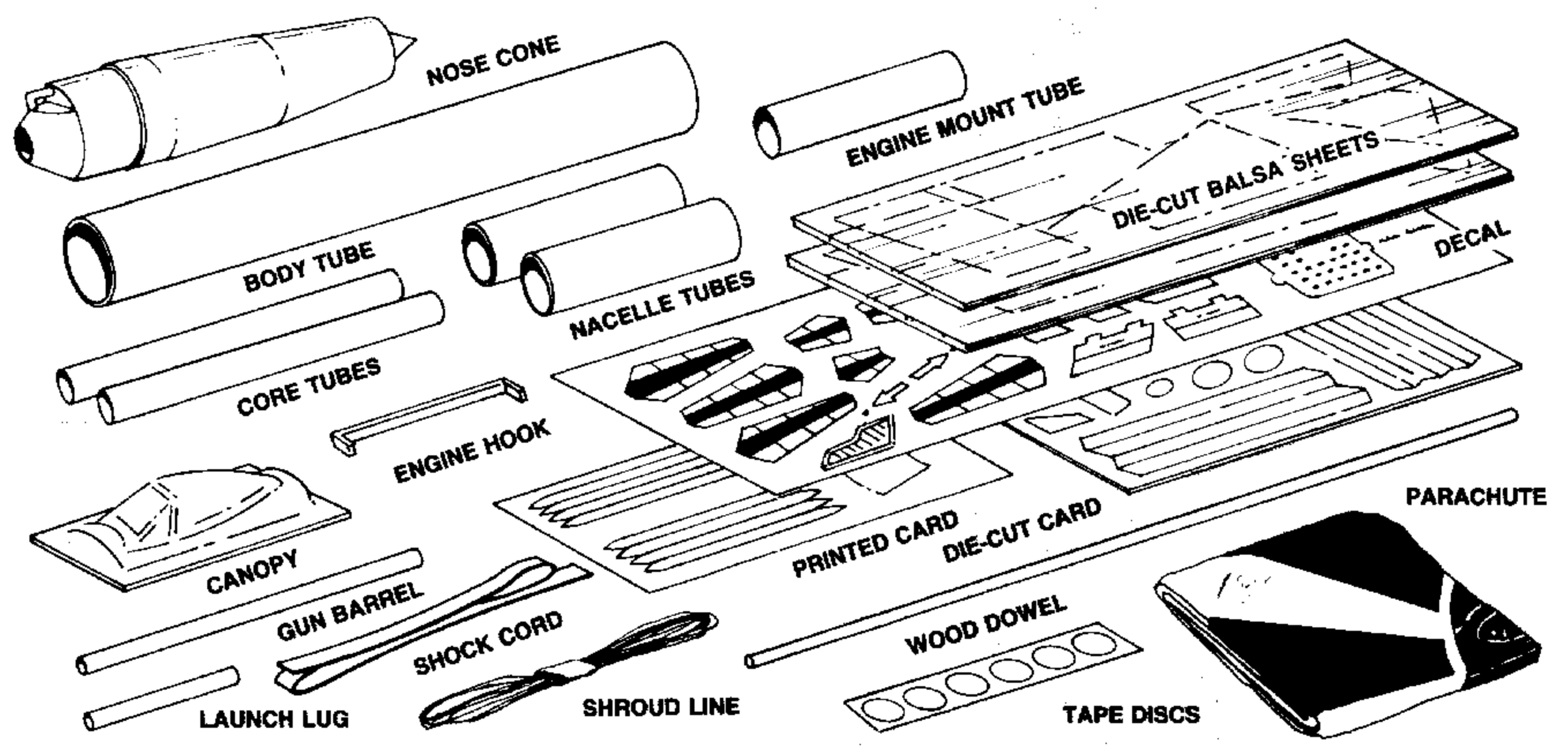

In addition to the parts included in the kit you will also need:

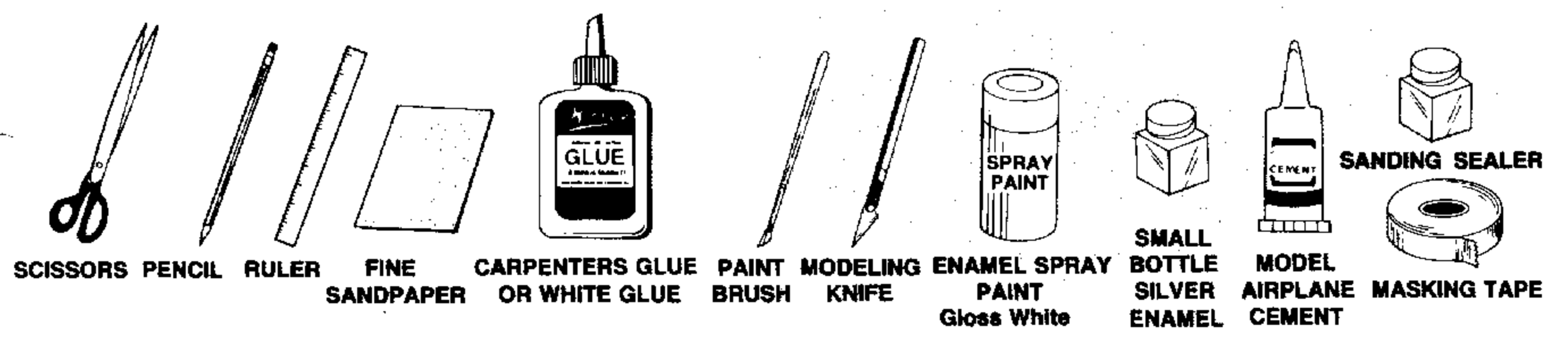

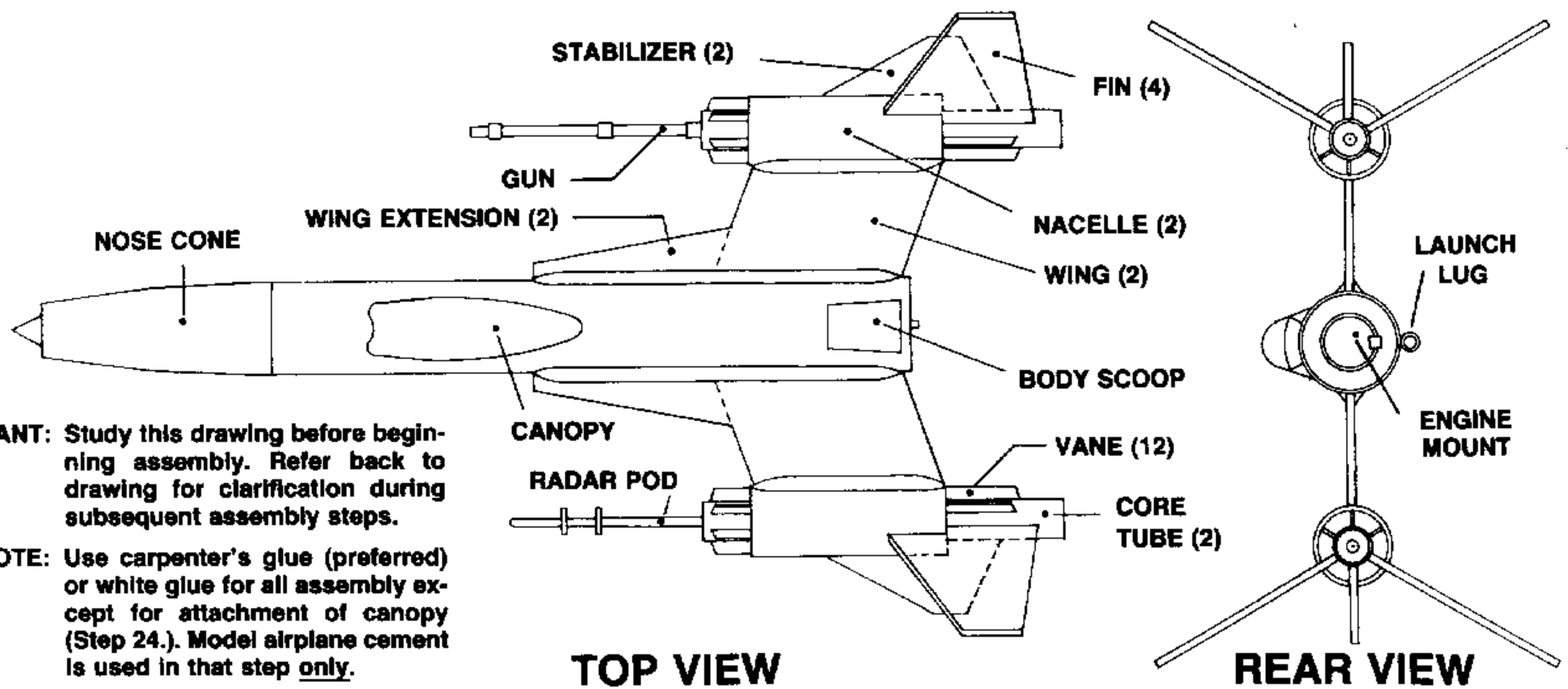

## ROCKET ASSEMBLY

**1.**

- Mark engine mount tube 1 inch and 2½ inches from one end. Cut a 1/8 inch wide slit at the 2½ inch mark.
- Gently bend engine hook so it has a very slight upward bow. Insert one end of hook into slit.
- Remove two large rings from card. Slide one ring over tube and hook and position at 1 inch mark. Apply glue to both sides of ring-tube joint. Glue remaining ring to front of tube, about 1/16th inch from end. Apply glue to both sides of this ring.

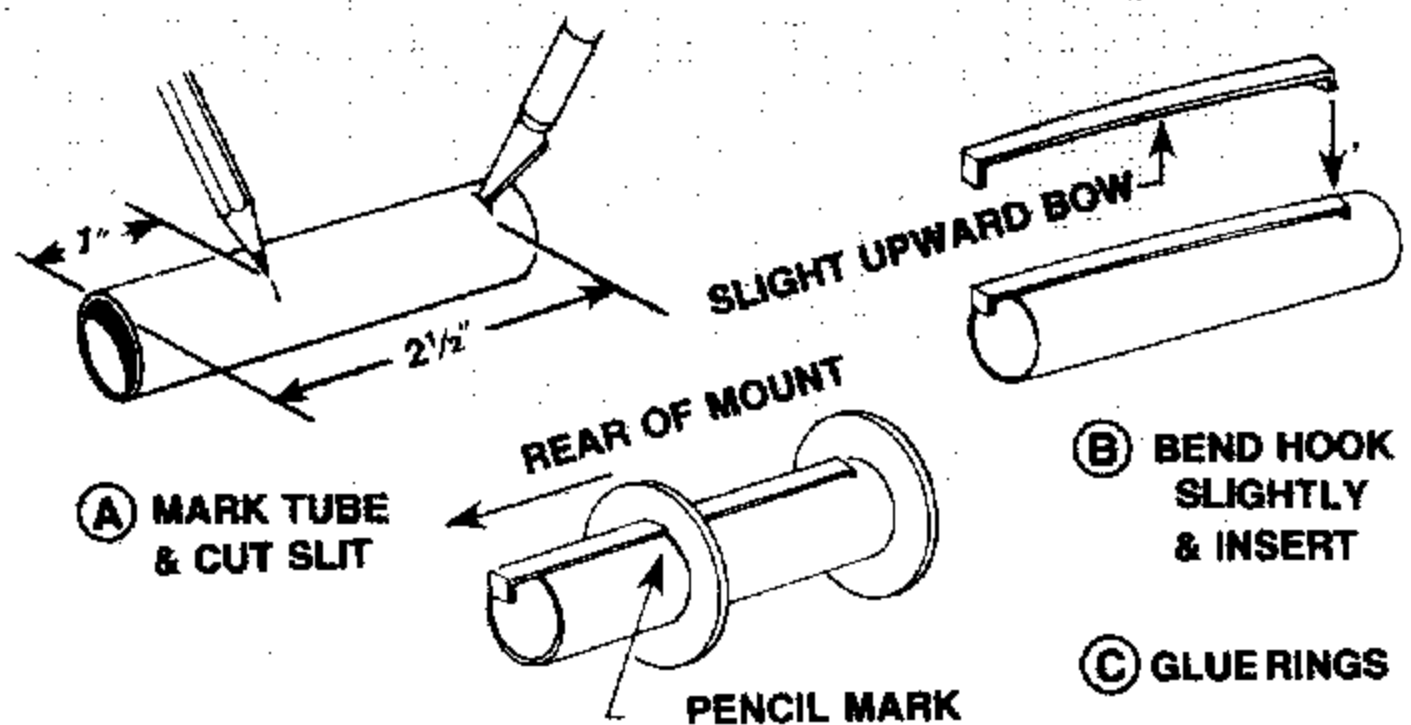

**2.**

- Sand both sides of balsa sheets. Run knife along die-cut lines to free parts from sheets.
- Stack identical parts together and sand edges.

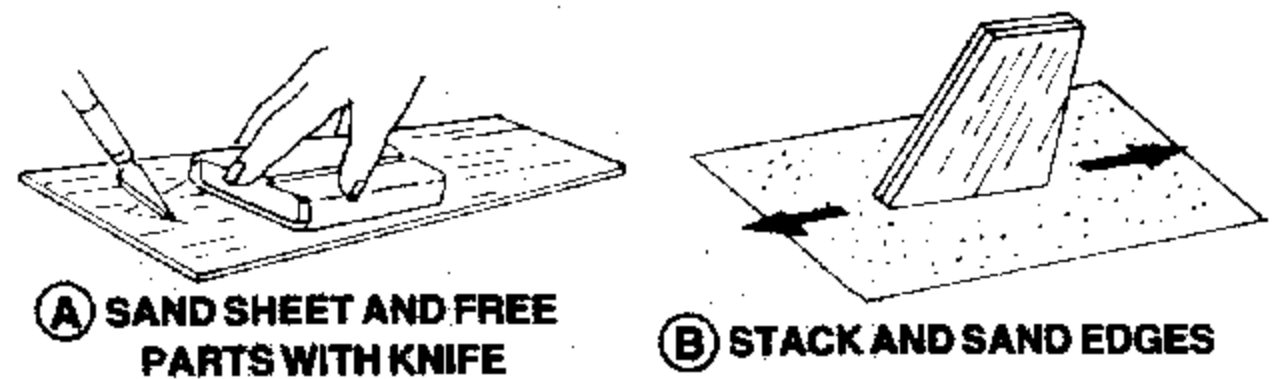

**3.**

- Using a piece of scrap balsa as applicator, apply a bead of glue around inside of body tube about 2 inches from end.
- Insert engine mount into body and push forward until rear edge of engine tube is even with rear of body.
- Using stick, apply glue around rear ring-body joint. Stand on end and let glue dry.

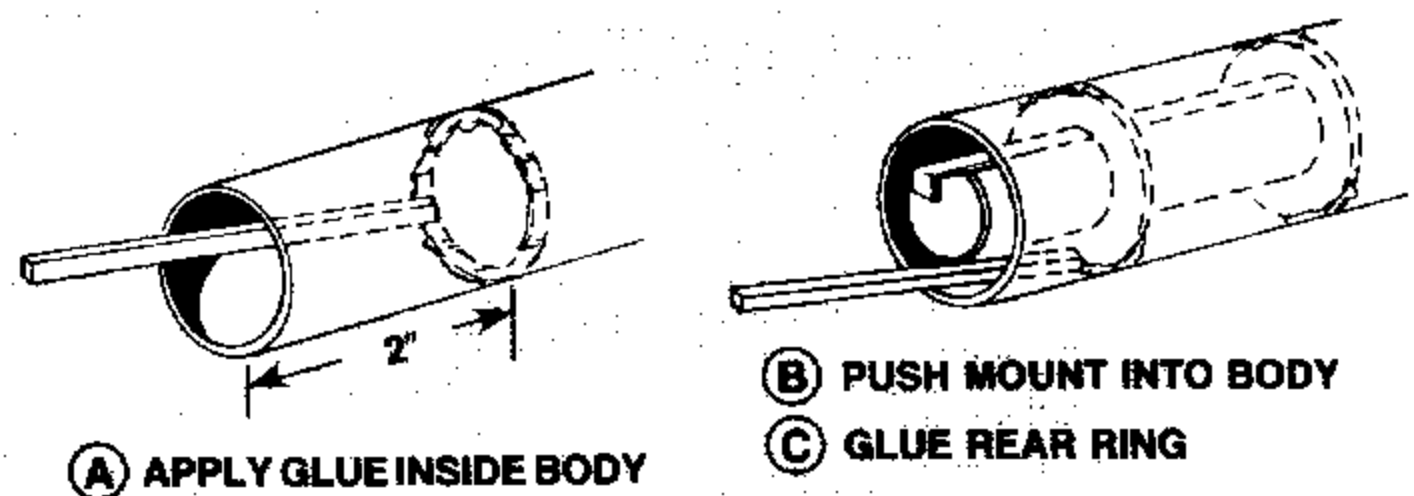

**4.**

- Cut body tube marking guide from page 5 of instructions.
- Wrap guide around body and tape ends together. Rotate guide so engine hook is aligned with launch lug line. Mark body at arrow points. Print 'LL' on body next to launch lug line.
- Remove guide. Using a door frame as marking guide, draw lines along length of body at all marks.

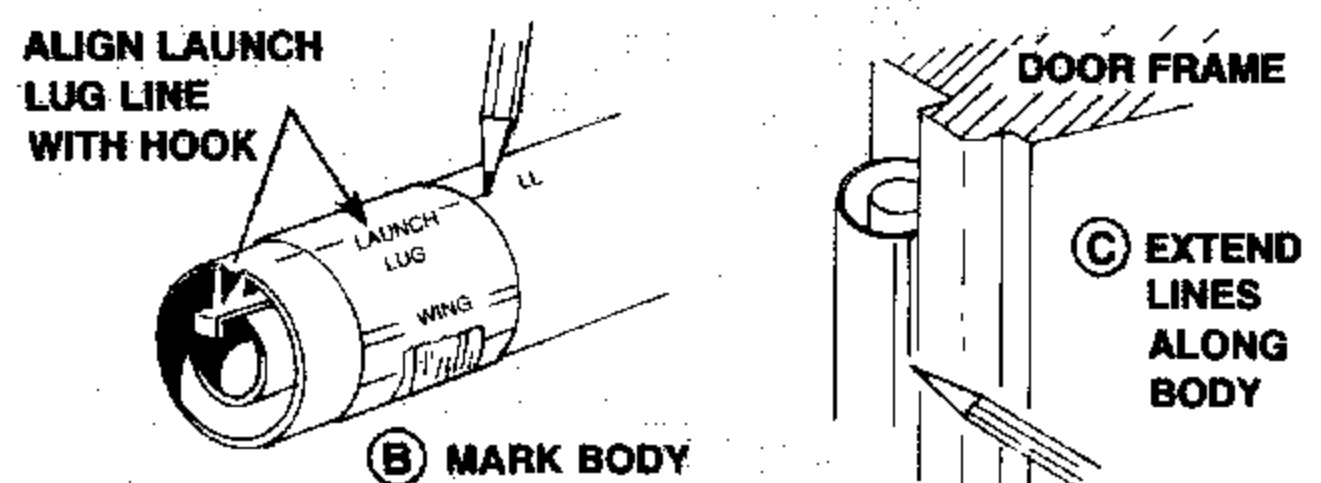

## 5.

- A. Cut wing and nacelle support pads from back of panel. Fold supports and tape ends together.  
Glue wing to body on wing lines with rear of wing 1/8th inch from rear of body. Align wing so it points straight out from body. Hold till glue begins to set.
- C. Attach remaining wing to opposite side.
- D. Lay body on flat surface and place supports under wings. Let glue dry.
- E. Glue wing extensions to front of wings.

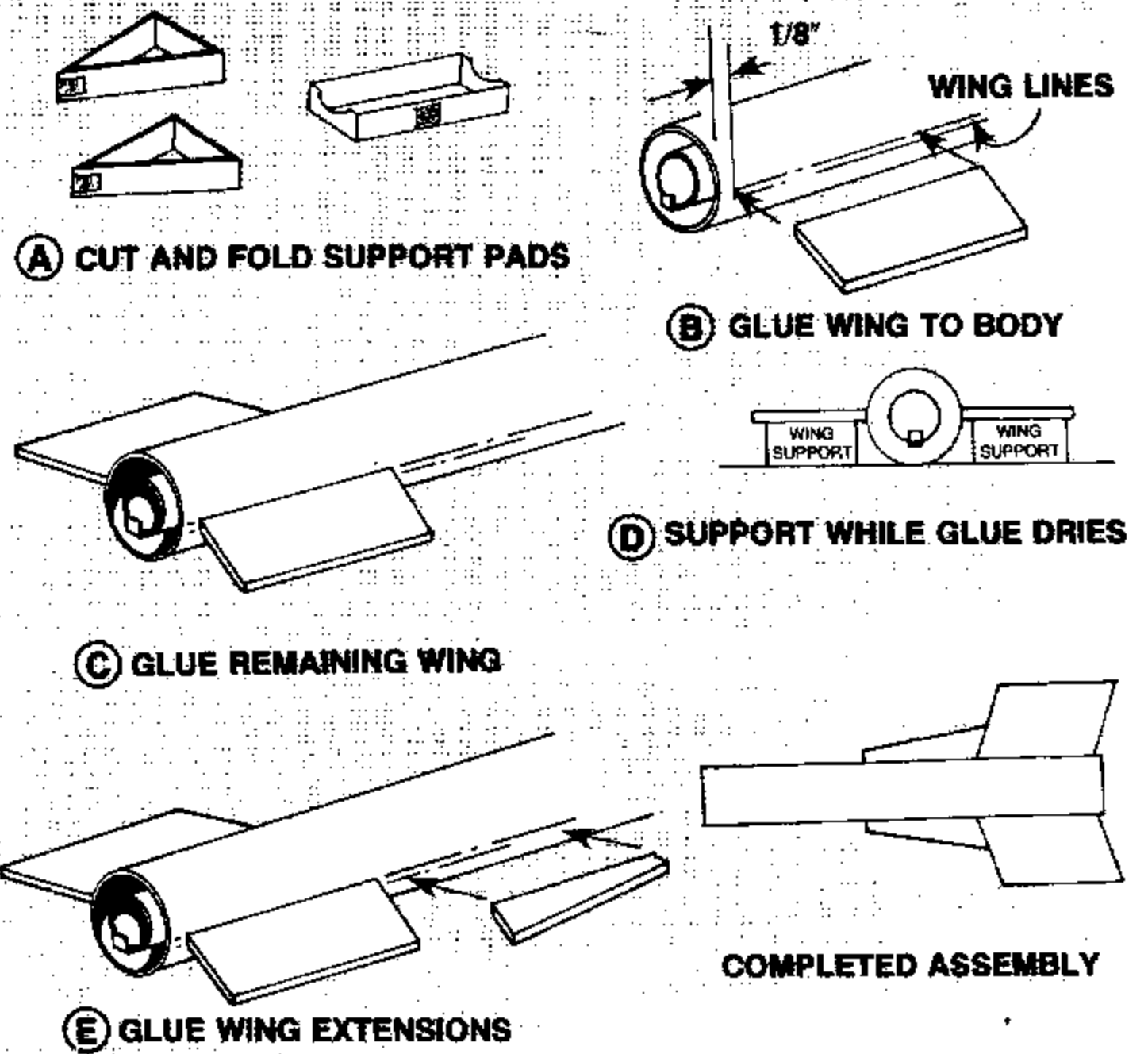

## 6.

- A. Cut nacelle marking guide from page 5. Mark both nacelle tubes at arrow points. Print 'W' next to wing marks. Using the door frame again as a guide, draw lines a long length of tubes.
- B. Apply a bead of glue to a nacelle between wing lines (Make sure it is the wing lines.) and glue nacelle to end of a wing.
- C. Set assembly on a flat surface with wing supports under wings and nacelle cradled in its support.
- D. After glue has dried, attach remaining nacelle to other wing in same manner.

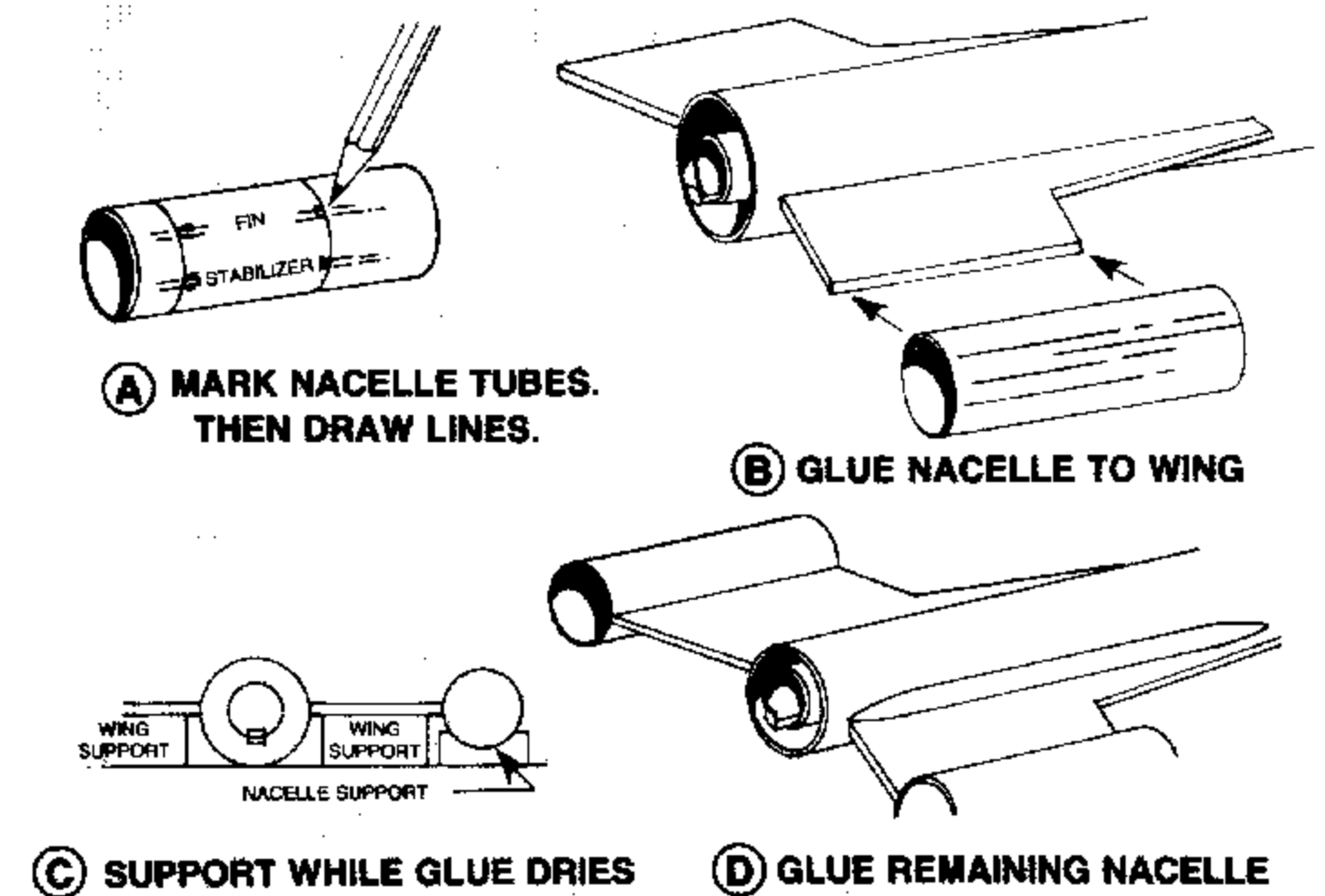

## 7.

- A. Remove three body scoop parts from die-cut card and cut scoop top from printed card. Glue side pieces to rear of scoop. Form a curve in top piece and glue it to assembly. Allow glue to dry.
- B. Glue scoop to top of body 1/8 inch from rear and centered on top center line (opposite side of body from launch lug line).

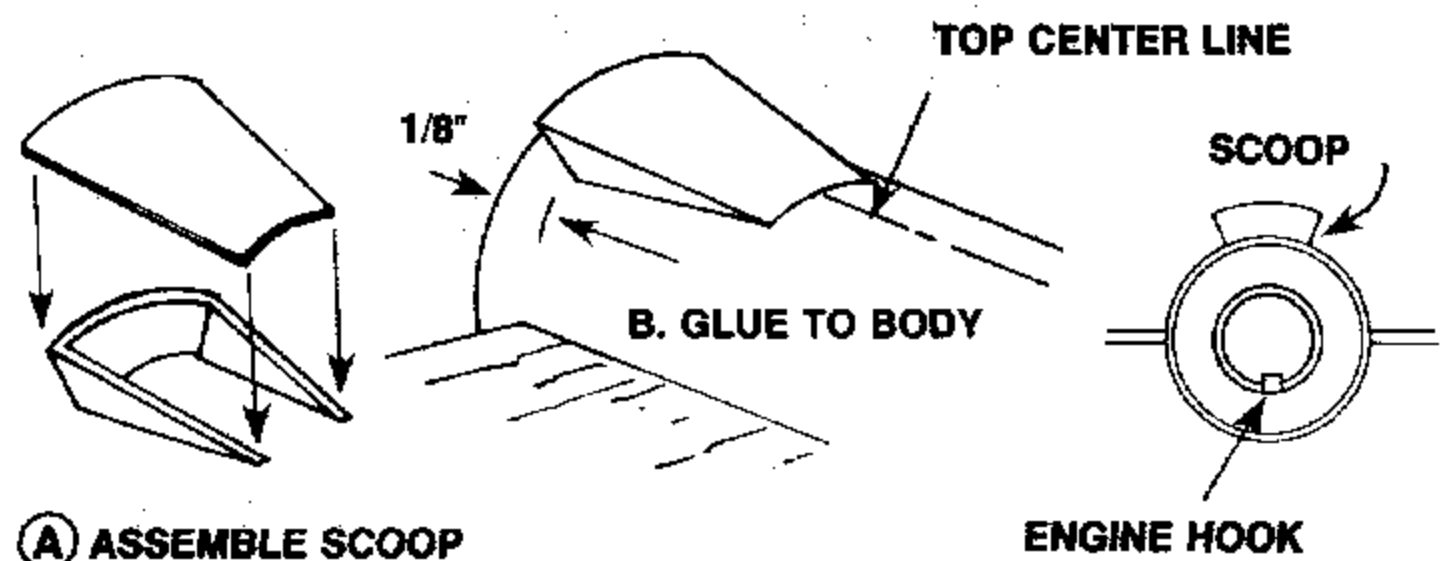

## 8.

- A. Apply reinforcing fillets of glue to both sides of wings where they join body and nacelles. Keep glue back about 1/4 inch from ends of wings.
- B. Lay flat on table with supports under wings and allow glue to dry completely.

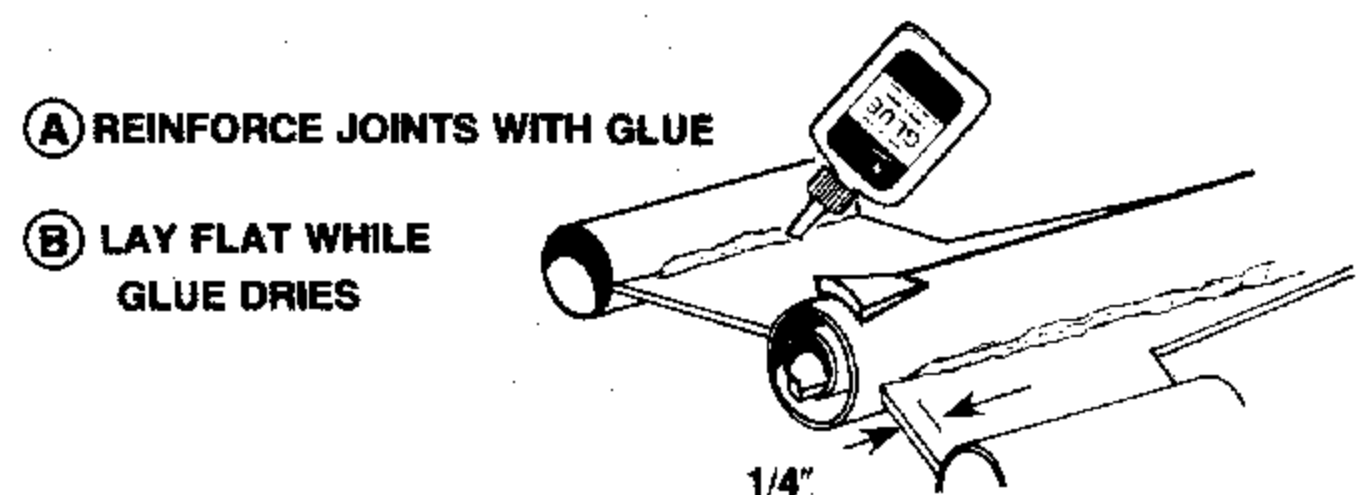

## 9.

- Cut a 3/16 inch wide strip from edge of instruction sheet. Cut three pieces from strip, each 2 1/2 inches long.
- Mark gun barrel tube at dimensions shown. Glue strips of paper around barrel at marks.
- Remove from die-cut card the two rings which have a hole large enough to fit over barrel. Push one ring onto barrel and against paper wrap. Glue in place. Glue second ring onto rear end of barrel.
- Cut 1 3/4 inch long piece from wood dowel. Glue to barrel in position shown. Cut remainder of paper strip into two 1 3/4 inch pieces and glue around barrel and dowel.

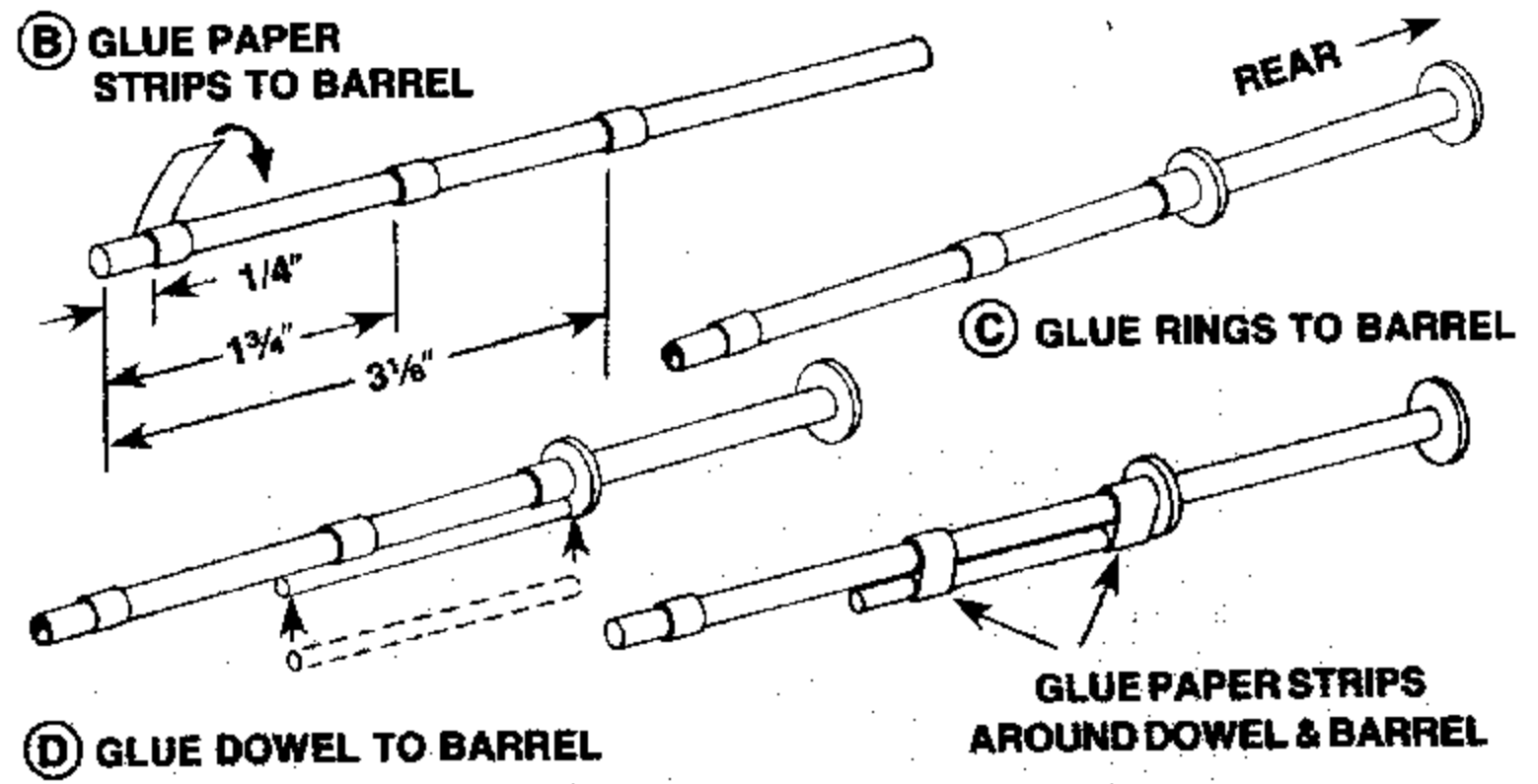

## 10.

- Cut a 4 1/4 inch piece from dowel. Sand one end round. Measure from round end and mark dowel at dimensions shown.
- Remove two 3/8 inch diameter and two 1/2 inch diameter rings from card. Glue these onto dowel at marks. Note that two smaller rings are at 3/4 and 1 1/2 inch marks.

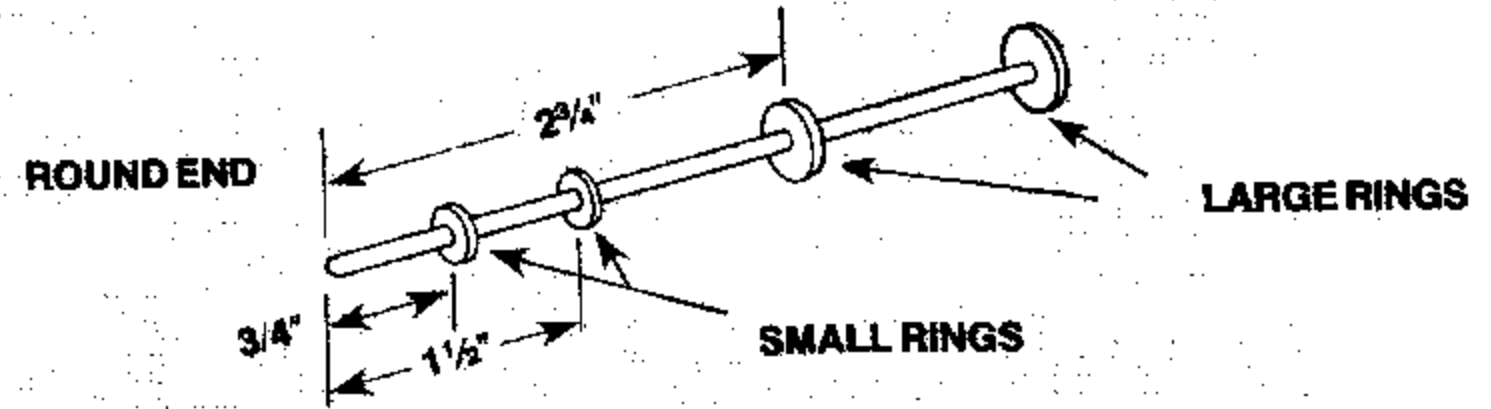

## 11.

- Cut out core tube marking guide from page 5. Mark both core tubes at all arrow points. Draw lines full length of tubes.
- Draw a line around each tube 3/32 inches from one end. Remove 12 vanes from die-cut card. Glue one long vane to core tube, centered on a line with one end at the 3/32 inch mark.
- Next, glue two more long vanes on center line on either side of the first vane. Use template at right to insure that vanes extend from tube at the proper angle.
- Glue three short vanes on the remaining center lines. These vanes have one end angled and the other end square. Make sure angled end is at front of tube. Glue six remaining vanes to second core tube in same manner.
- Glue two remaining die-cut rings into rear of core tubes.

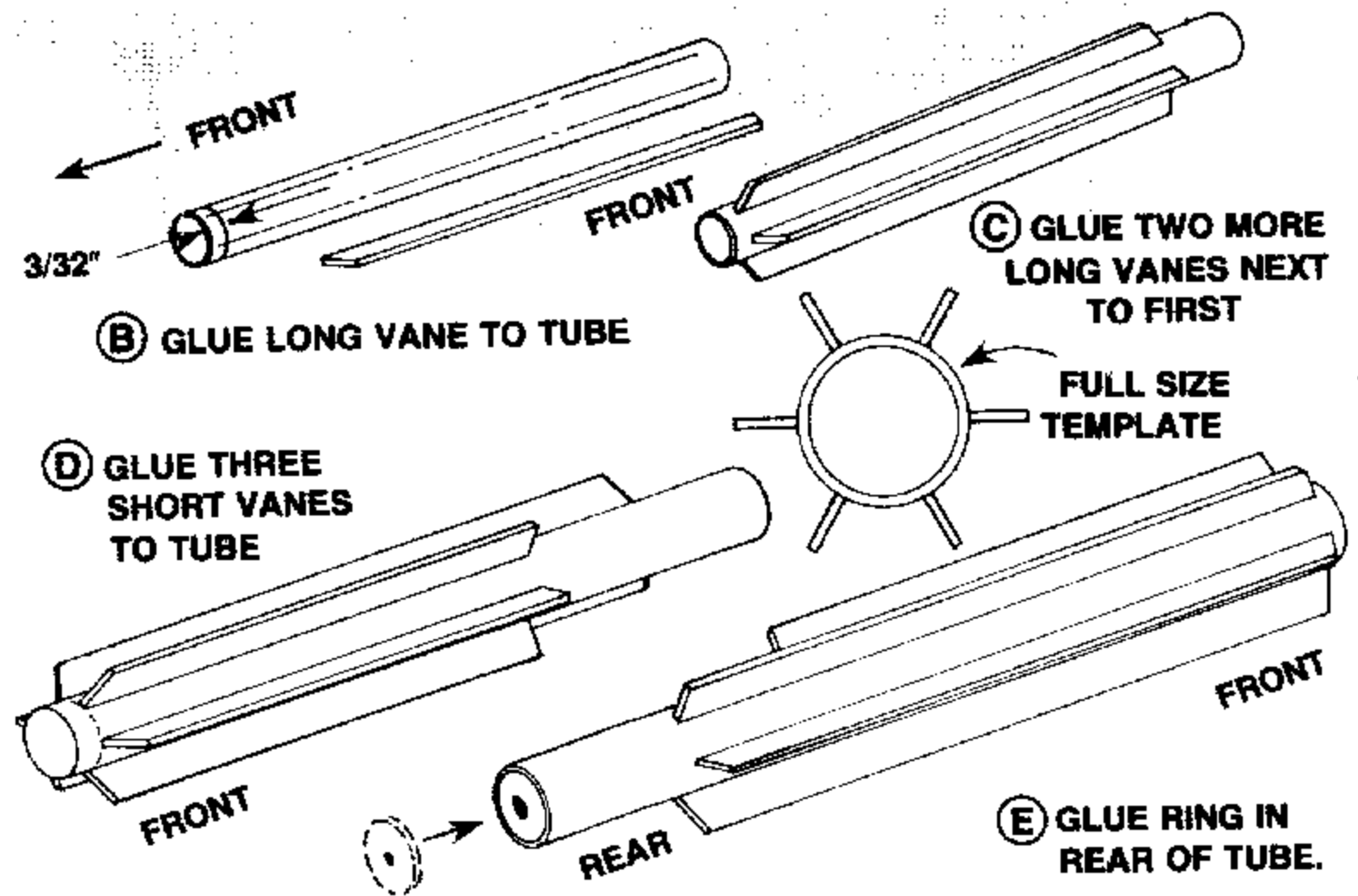

## 12.

- Cut fairing strips from printed card. Curl ends of a long fairing down slightly. Apply glue to back of fairing and attach to a body-wing joint. With ends pushed down into crux of joint, fairing will center itself between body and wing. Smooth fairing with your finger. Apply remaining long fairings to body wing joints. Apply short fairings to joints between wings and nacelles.
- After glue dries, run glue along edges of fairings and smooth out with your finger.

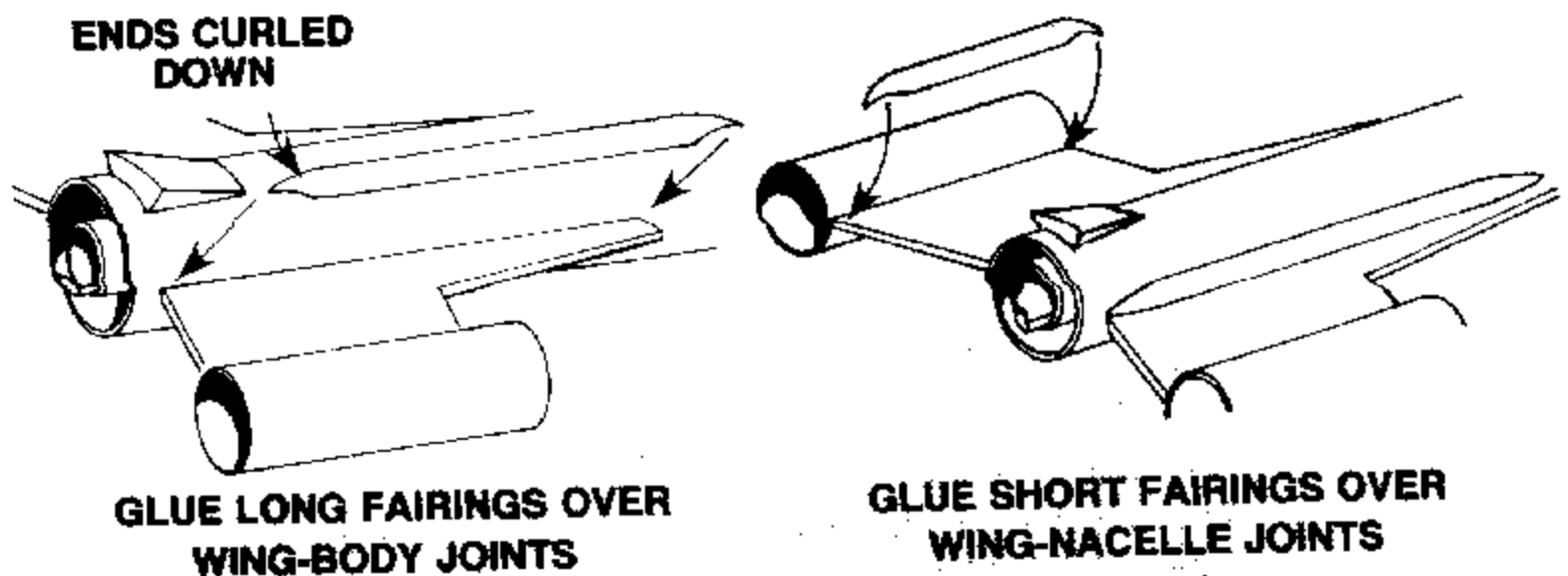

## 13.

- Slide a core unit into a nacelle. If fit is too tight, sand outside edges of vanes. Position core unit so long vanes point in toward body and rear edges of short vanes are even with rear of nacelle. Note that middle long vane is aligned with wing. Study drawing to make sure core unit is correctly positioned. Use a toothpick to apply small beads of glue to joints between vanes and inside of nacelle.
- Glue second core unit into other nacelle in same manner.

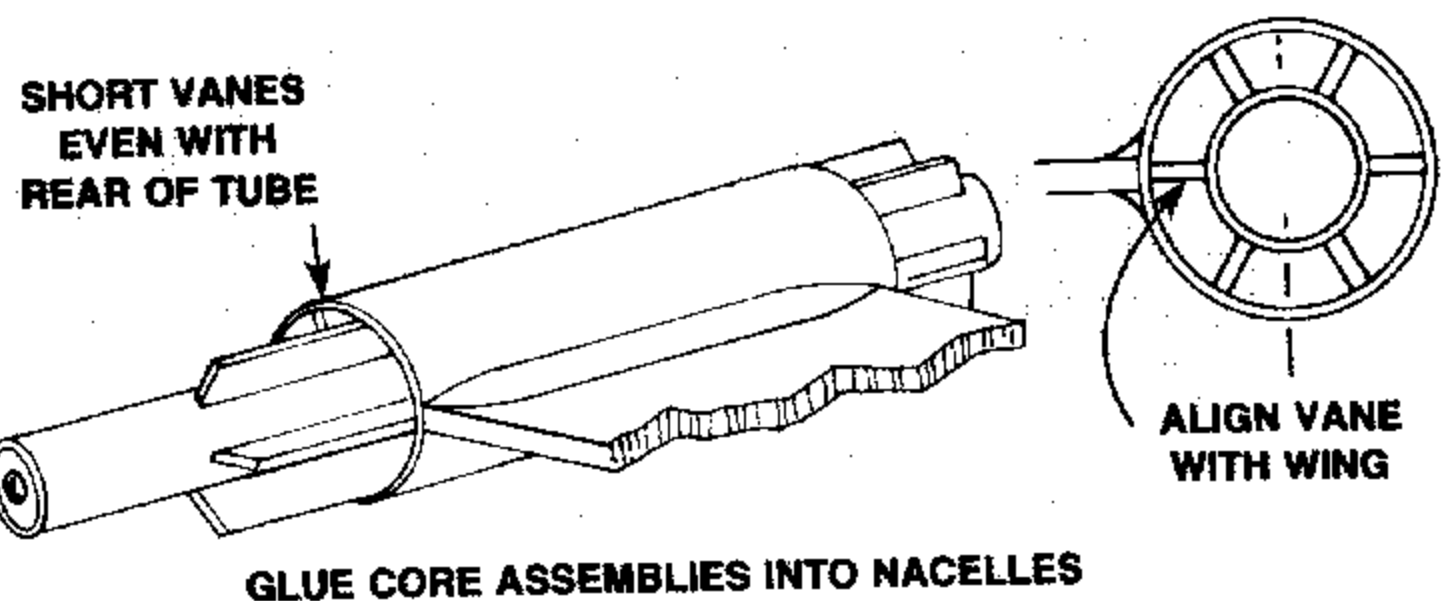

# 14.

- A. The gun is glued into the right core tube with dowel below barrel as shown in drawing. Apply glue inside core tube about 1½ inches from front end. Insert gun unit and position as shown.
- B. Apply a film of glue around end of ring and tube.
- C. Glue radar pod into left core tube in same manner.

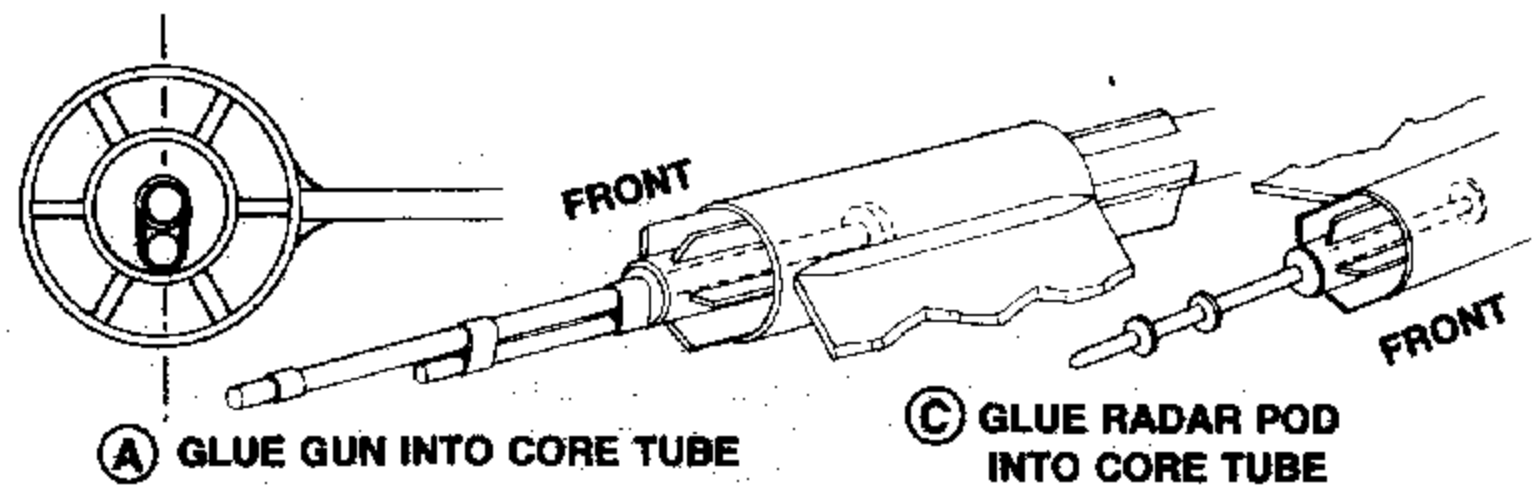

# 15.

- A. Glue the stabilizers to the outside of the nacelle bodies. The stabilizers extend straight out and are in line with wings.

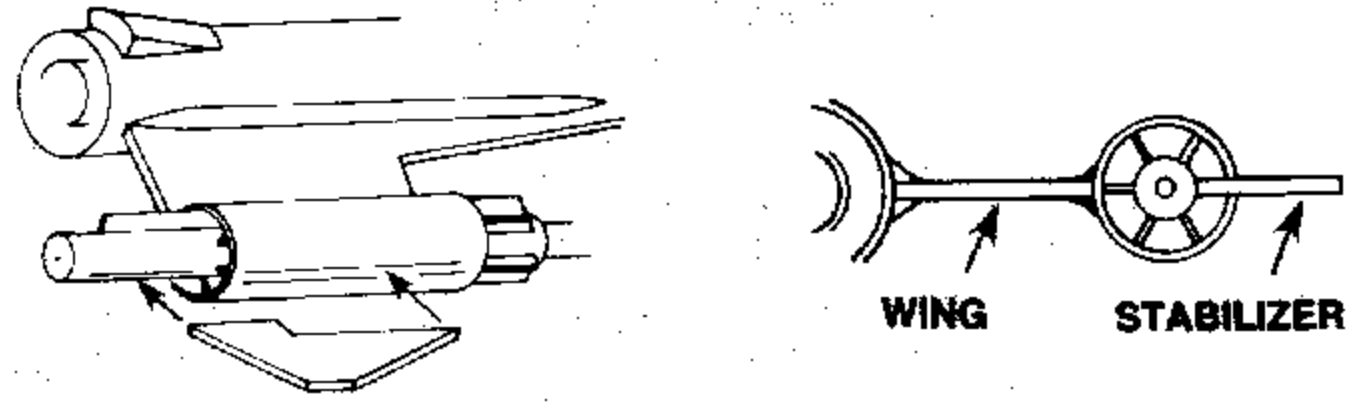

# 16.

- A. Mark the top center line at dimensions shown. Use knife point to make very small cuts on center line at marks. These slight cuts will still be visible after painting and will be used to locate the cockpit.

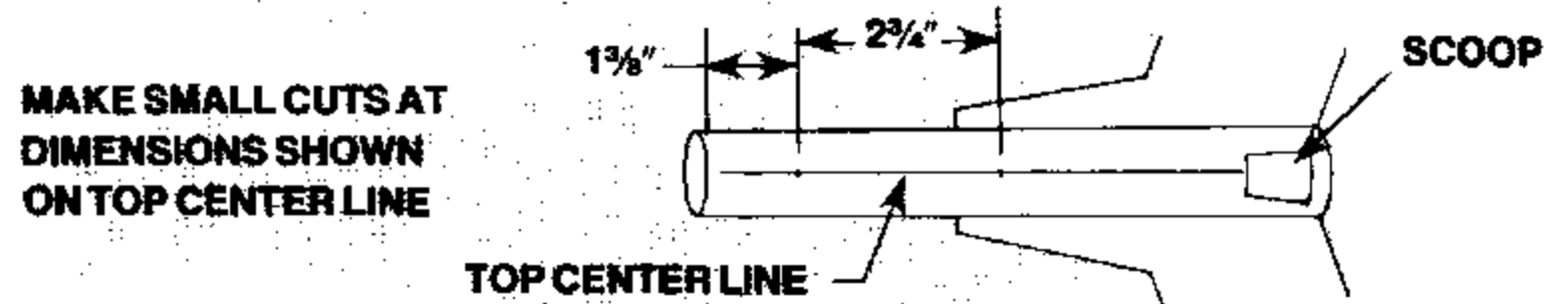

# 17.

- A. Cut the alignment guide from back of kit panel. Glue a fin to top of nacelle and core tube in position shown. Use alignment guide to provide correct angle to fin. Place model on flat surface and allow glue to dry. Periodically check alignment with guide to insure fin has not moved.
- B. Glue fin to top of other nacelle in same manner. After glue dries, turn model over and attach two remaining fins to bottoms of nacelles. Do not let model rest on top fins while glue dries on bottom fins. Instead, allow fins to extend off edge of table.
- C. After glue has dried, all fin and stabilizer joints should be reinforced. Apply a small bead of glue along a joint. Pull your little finger along joint to smooth glue into an even fillet and to remove excess glue. After all joints are filleted, support model in horizontal position while glue dries.

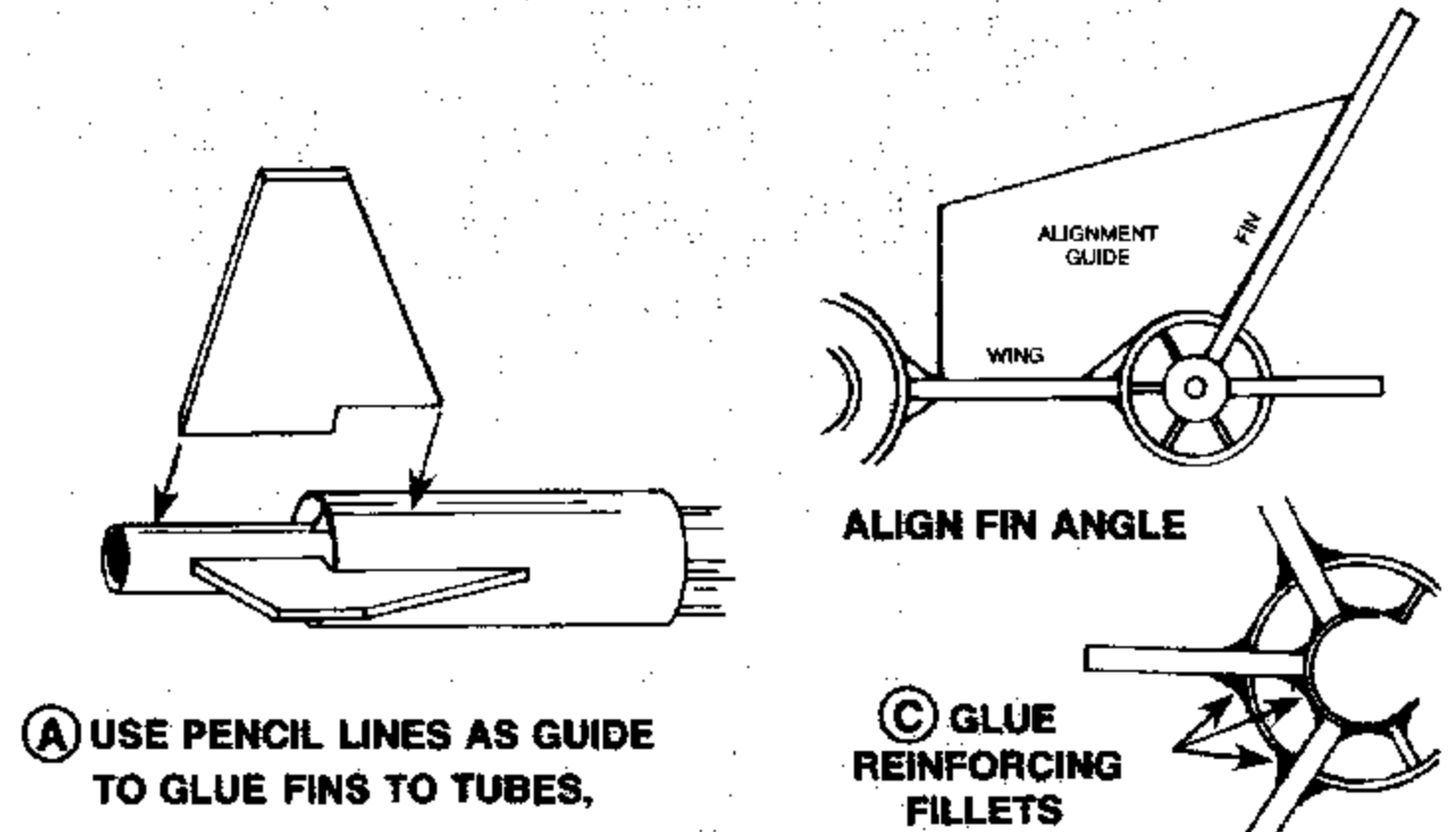

# 18.

- A. Glue launch lug to bottom of body in position shown. Add small beads of glue to both sides of joint between lug and body to provide additional strength. Smooth glue with finger.

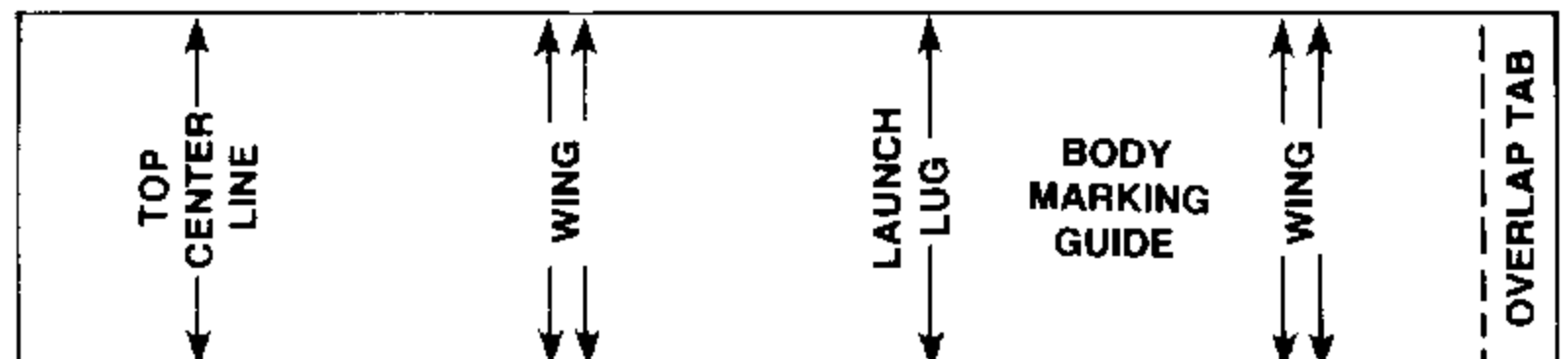
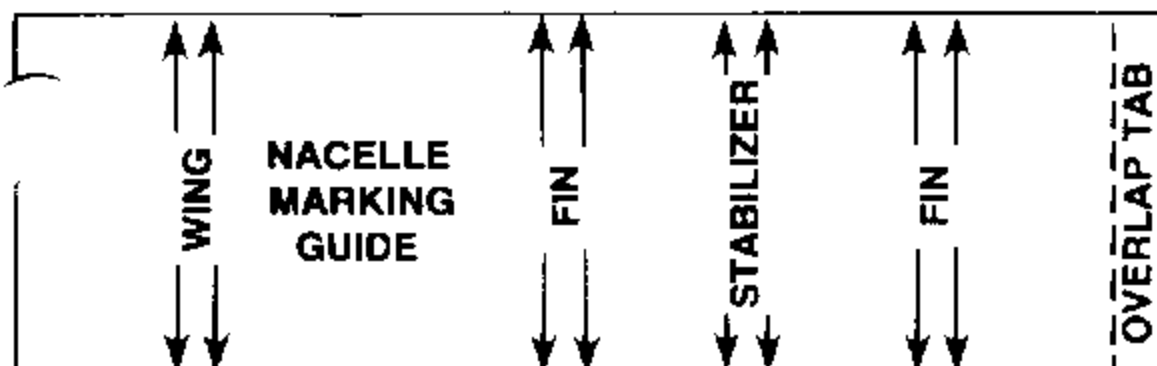
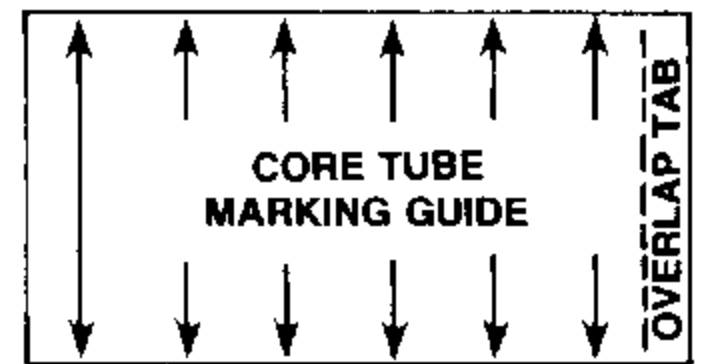
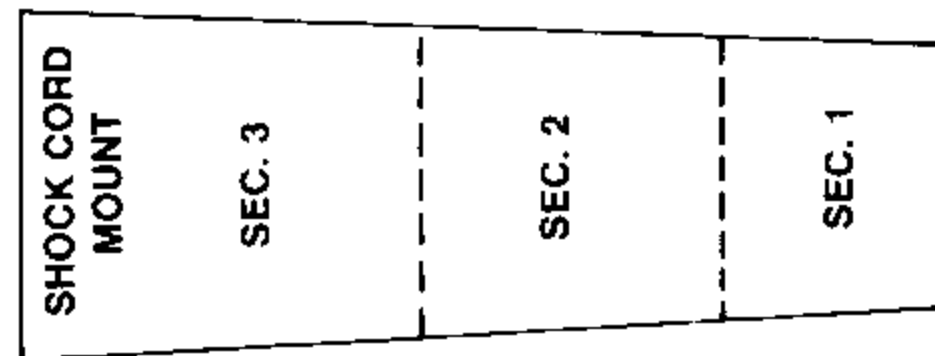
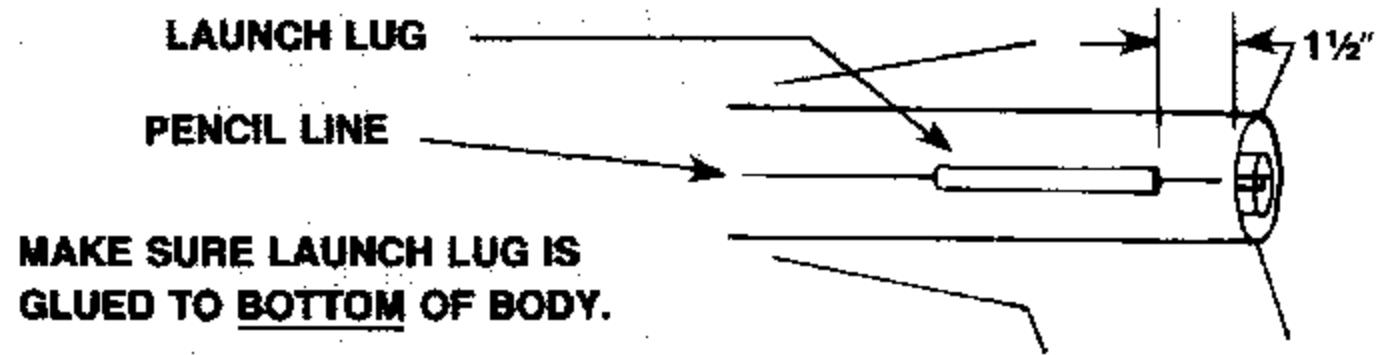

## 19.

- Cut shock cord mount from page 5 of instructions.
- Crease on dotted lines by folding. Spread glue on section 1 and lay end of shock cord into glue. Fold over and apply glue to back of first section and exposed part of section 2. Lay shock cord as shown and fold mount over again.
- Clamp unit together with fingers until glue sets.

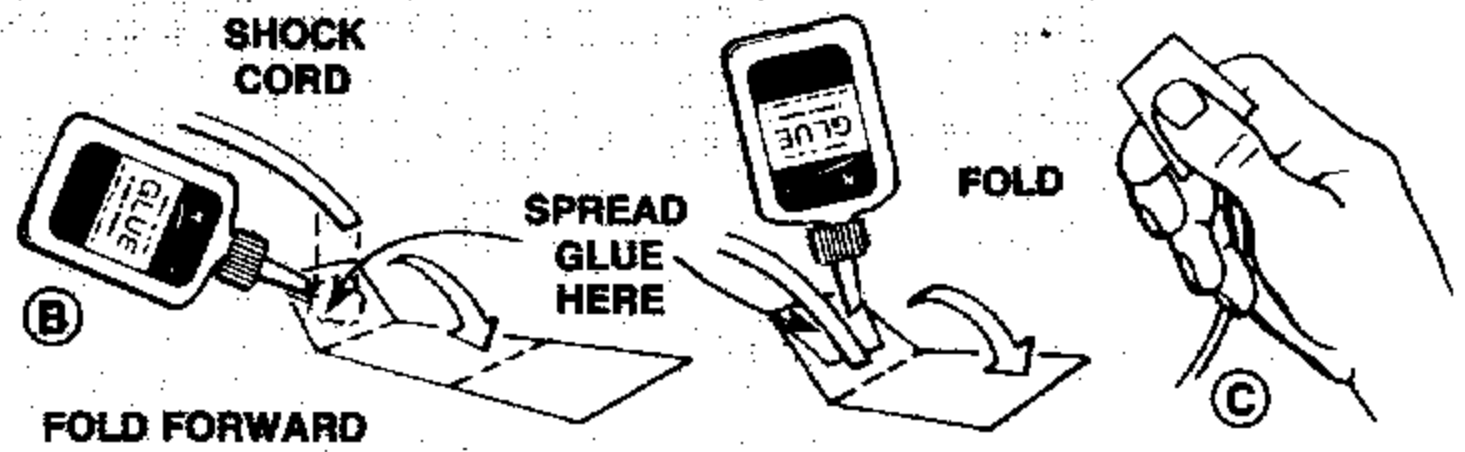

## 20.

- Apply glue to inside front of body tube to cover an area no less than 1 1/4 inches to 2 inches from end. The glued area should be same size as shock cord mount.
- Press mount firmly into glue as shown.
- Hold until glue sets.

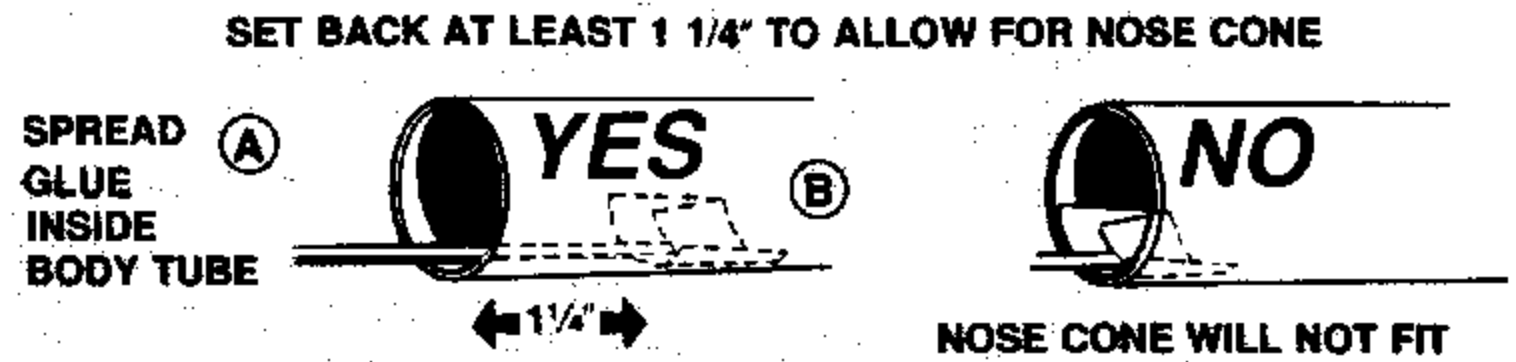

## 21.

- Trim excess plastic from part lines of nose cone with a sharp knife. Also remove any excess plastic from inside molded eyelet. Wipe nose cone with damp cloth to remove oil and dirt.

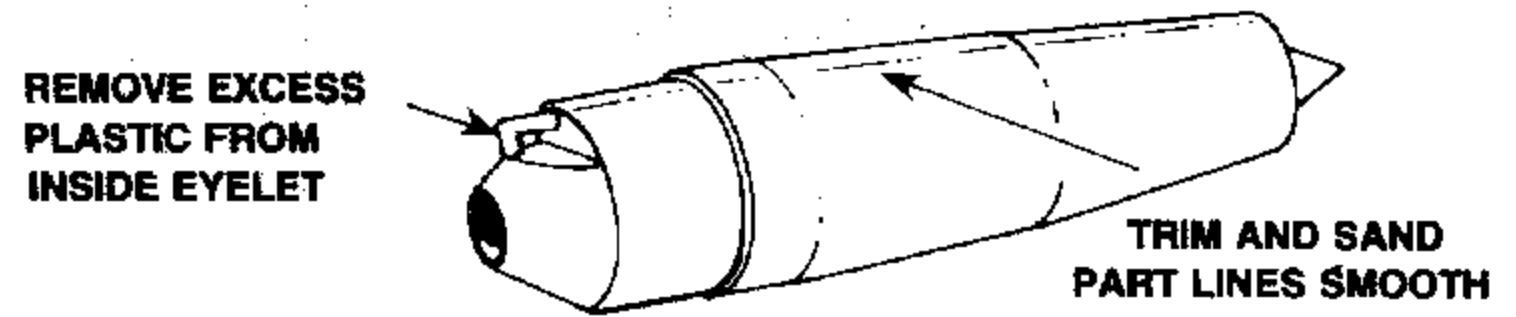

## 22.

- Cut out parachute on edge lines.
- Cut three 35 inch lengths of shroud line.
- Form small loops with ends of shroud line and press onto sticky side of tape discs. Attach tape discs with line ends to top of parachute as shown.
- Press tape discs firmly into place until tape discs and parachute material are molded around shroud line loops.
- Pass shroud line loops through eyelet on nose cone. Pass parachute through loop ends and pull lines tight against the nose cone.
- Tie free end of shock cord to nose cone eyelet.

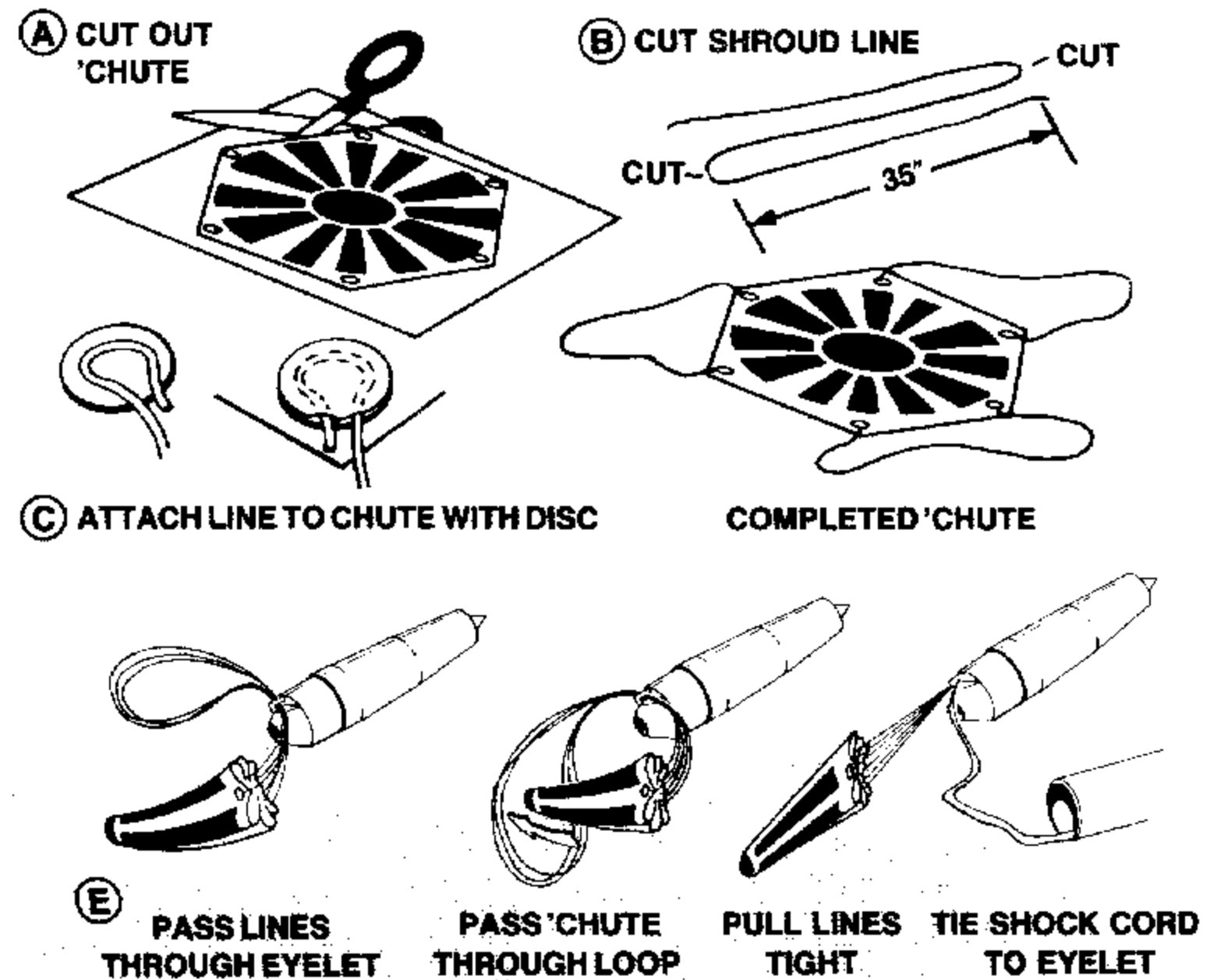

## 23.

- Cut material away from sides and ends of canopy sheet as shown.
- Wrap sandpaper around body and pull canopy back and forth across sandpaper. The base material will become frosted from sanding and will provide visible line for cutting out canopy.
- Using a small scissors, carefully cut out canopy. Be careful not to cut away small flange around bottom of canopy. This will be used as gluing surface to attach canopy to body.
- Wrap sandpaper around body again and sand bottom of canopy to make it smooth. Lightly sand edges of canopy and lay it aside for time being.

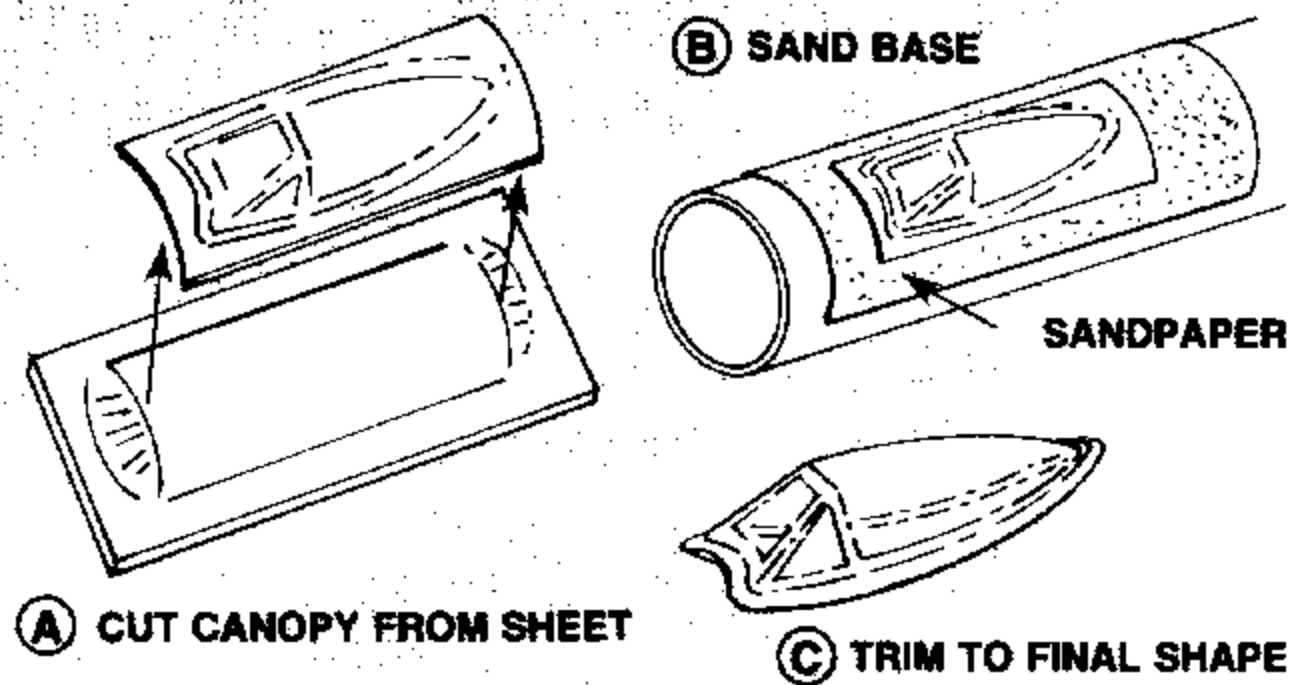

## 24.

- Apply sanding sealer to balsa surfaces. Let dry, then sand. Repeat sealing and sanding until balsa grain lines are filled.
- Tightly roll piece of paper and insert into engine tube to serve as paint holder. Lightly spray gloss white enamel into front and rear of nacelles to cover visible portions of core tubes and vanes. Spray entire model, using several light coats and spraying from several directions. Let paint dry.
- Brush paint gun and radar pod silver. Canopy may be brush painted by spraying small amount of white into spray can cap, then carefully painting raised areas with small brush. Canopy may also be spray painted after first applying small pieces of masking tape over all areas which remain clear. Be sure all clear areas are covered. Apply long strips of masking tape to underside of base to prevent overspray from getting inside canopy. Decal segments have narrow border of clear material surrounding printed area. Some decals require that all or portion of clear border be cut away as close as possible to printed edge. Cut out decals shown at right, trimming away clear where indicated.
- Use photo on front of instructions as guide for decal locations. Apply cockpit decal first. Soak decal in water until it slides on backing (20 to 30 seconds). Slide decal from backing onto top of body. Position decal so black marks at front and rear are aligned with cut marks on body (step 16). Being careful not to move decal, blot away water and press out air bubbles with soft cloth. Next apply decals around leading edges of fins. Center decals on leading edges and gently press down onto sides of fins. Smooth decals into place with cloth. In same manner, apply shorter decals over tips of fins and small red decals over ends of stabilizers. Aileron decals are applied to top rear edges of wings and black ring decal is applied to front of nose around conical tip.
- Place canopy on body and center it over cockpit decal. Draw light pencil line on body around outside of canopy. Lay canopy aside. Using tip of knife blade, scrap away narrow strip of paint on body between decal edge and pencil line. Apply airplane cement around underneath side of canopy base and glue it in place over decal. Remove excess glue with tip of knife blade. If necessary, touch up around edge of canopy with white paint. Apply the black anti-glare decal in front of canopy. After decal is completely dry, cut through decal where body is joined to nose cone. Apply remaining decals to model and allow to dry several hours.

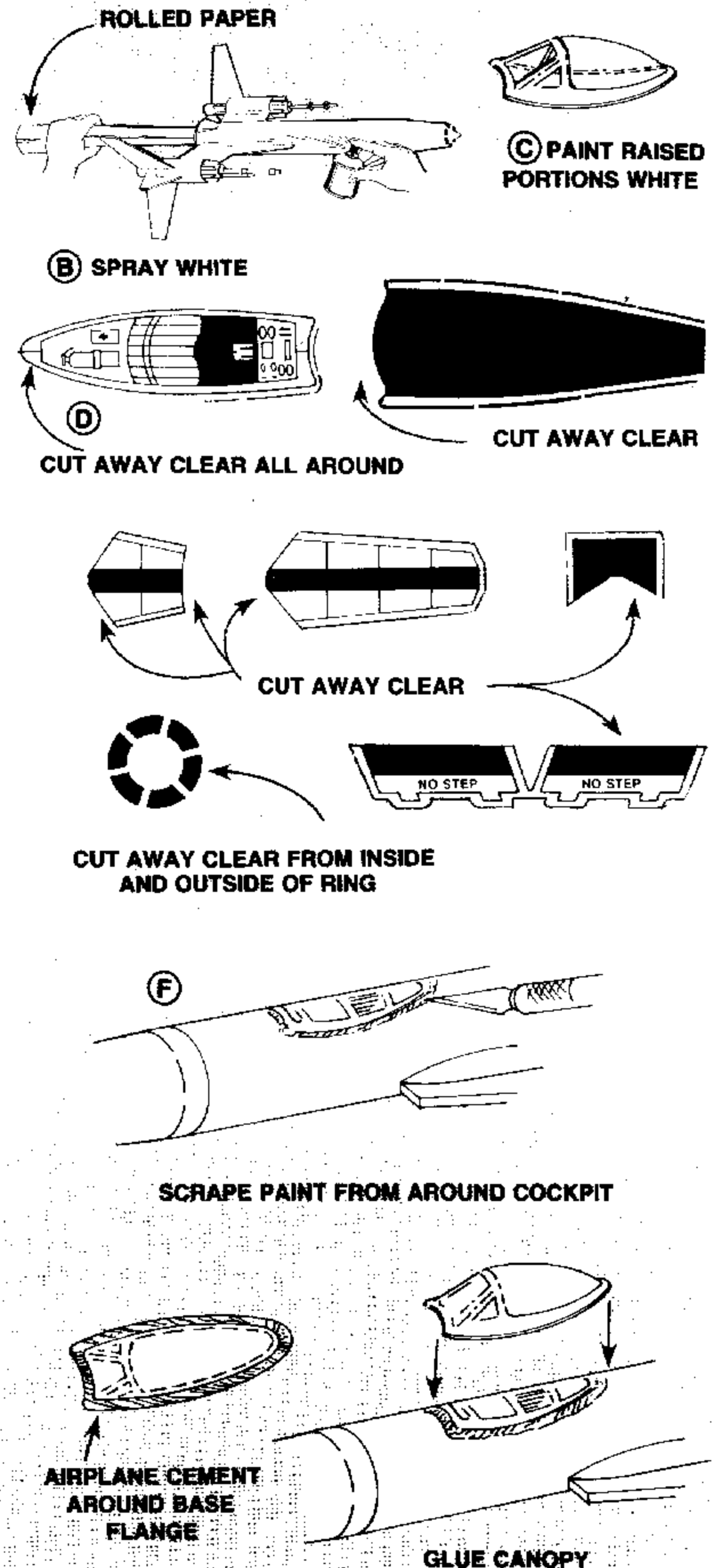

# ROCKET PREFLIGHT

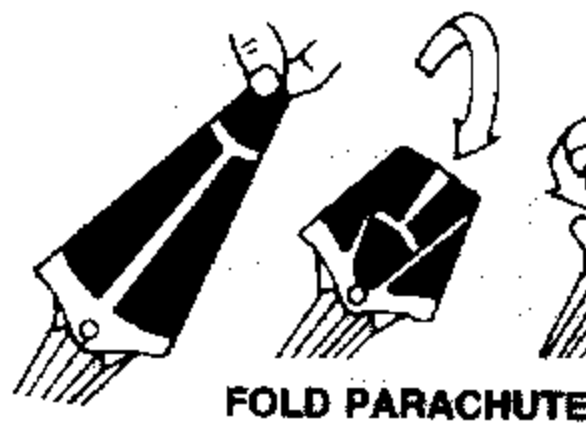
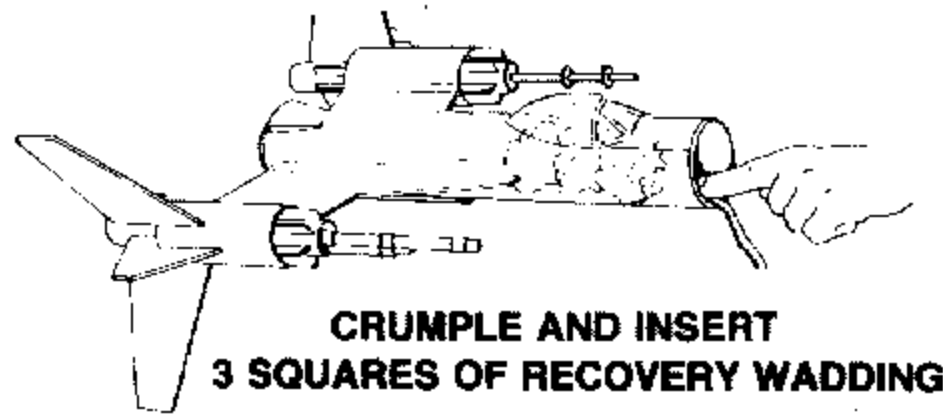

**WRAP LINES LOOSELY  
AROUND CHUTE.  
INSERT  
PARACHUTE  
IN ROCKET.**

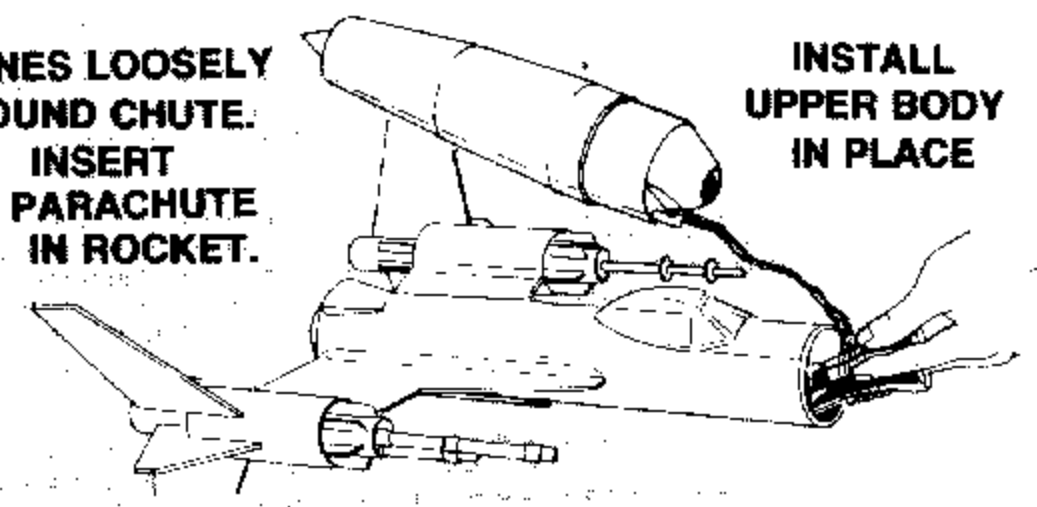

# PREPARE ENGINE

**SEPARATE THE IGNITERS**

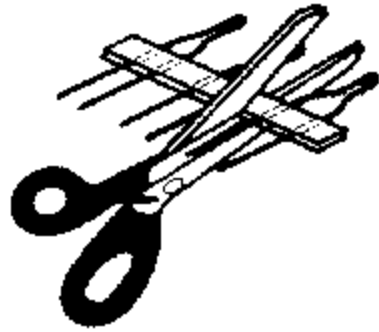

**ENGINE**

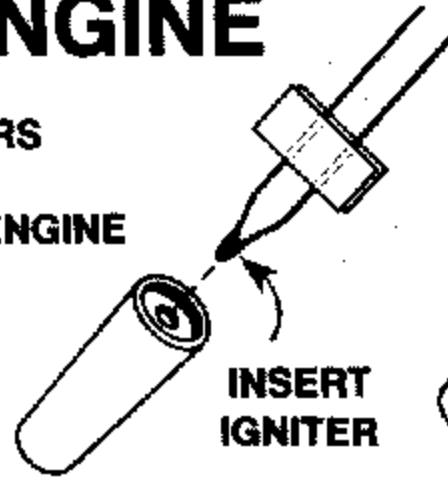

**IGNITER TIP MUST TOUCH  
PROPELLANT DEEP INSIDE  
NOZZLE OPENING**

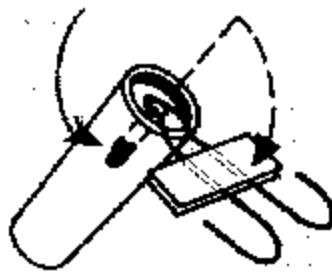

**FOLD  
OVER**

**BEND LEADS  
IN U SHAPES**

**APPLY AND FIRMLY  
PRESS MASKING  
TAPE IN PLACE**

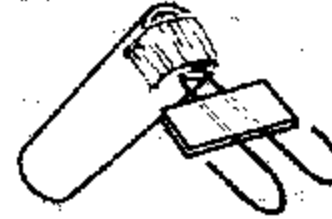

**INSTALL  
ENGINE IN ROCKET**

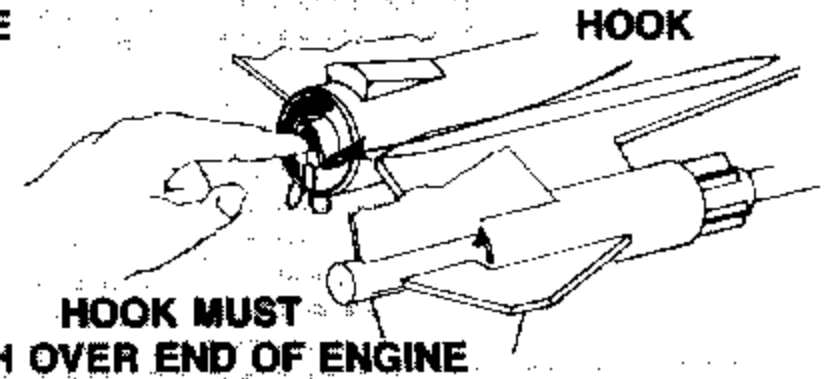

# LAUNCH SUPPLIES

To launch your rocket you will need the following items:

- Estes Electrical Launch System
- Estes Recovery Wadding (No. 2274)
- Recommended Estes Engines: B4-4, B6-4, or C6-3

To become familiar with your rocket's flight pattern, use a B4-4 engine for your first flight.

**Use only with Estes products.**

# FLYING YOUR ROCKET

Choose a large field away from power lines, tall trees, and low flying aircraft. Try to find a field at least 250 feet square. The larger the launch area, the better your chance of recovering your rocket. Football fields and playgrounds are great.

Launch area must be free of dry weeds and brown grass.

Launch only during calm weather with little or no wind and good visibility.

Don't leave parachute packed more than a minute or so before launch during cold weather [colder than 40° Fahrenheit (4° Celsius)].

Parachute may be dusted with talcum powder to avoid sticking

# MISFIRES

Failure of the model rocket engine to ignite is nearly always caused by incorrect igniter installation. An Estes igniter will function properly even if the coated tip is chipped. However, if the coated tip is not in direct contact with the engine propellant, it will only heat and not ignite the engine.

When an ignition failure occurs, remove the safety key from the launch control system and wait one minute before approaching the rocket. Remove the expended igniter from the engine and install a new one. Be certain the coated tip is in direct contact with the engine propellant, then tape the igniter leads firmly to base of engine as illustrated above. Repeat the countdown and launch procedure.

# FOR YOUR SAFETY AND ENJOYMENT

Always follow the NAR\* MODEL ROCKETRY SAFETY CODE while participating in any model rocketry activities.

\*National Association of Rocketry

# COUNTDOWN AND LAUNCH

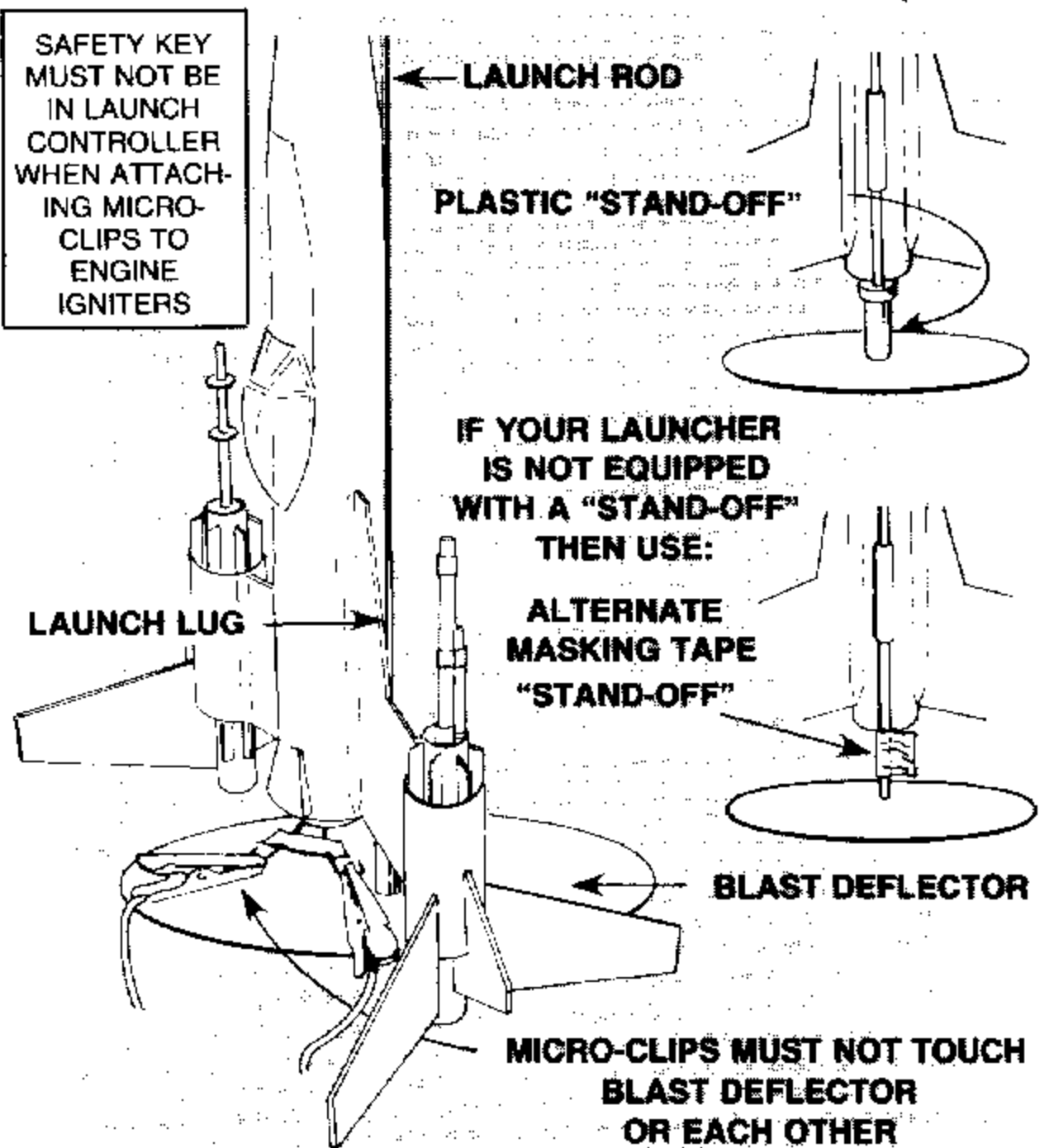

- ⑩ BE CERTAIN SAFETY KEY IS NOT IN LAUNCH CONTROLLER.
- ⑨ Remove safety cap and slide launch lug over launch rod to place rocket on launch pad. Make sure the rocket slides freely on the launch rod.
- ⑧ Attach micro-clips to the igniter wires. Arrange the clips so they do not touch each other or the metal blast deflector. Attach clips as close to protective tape on igniter as possible.
- ⑦ Move back from your rocket as far as launch wire will permit (at least 15 feet - 5 meters).
- ⑥ INSERT SAFETY KEY to arm the launch controller. Give audible countdown 5...4...3...2...1

**LAUNCH!!** PUSH AND HOLD LAUNCH BUTTON UNTIL ENGINE IGNITES

REMOVE SAFETY KEY FROM LAUNCH CONTROLLER. REPLACE SAFETY KEY AND SAFETY CAP ON LAUNCH ROD.