



ESTES INDUSTRIES
1295 H Street
Geneseo, CO 81240

SUPER VEGA™

FLYING MODEL ROCKET
#2036

*Started 3-2-95
Finished 4-2-95*



ASSEMBLY TIP

Read all instructions before beginning work on your model. Make sure you have all parts and supplies. Test-fit all parts together before applying any glue. If any parts don't fit properly, sand as required for precision assembly.

PARTS AND SUPPLIES

Locate the parts shown below and lay them out on the table in front of you.

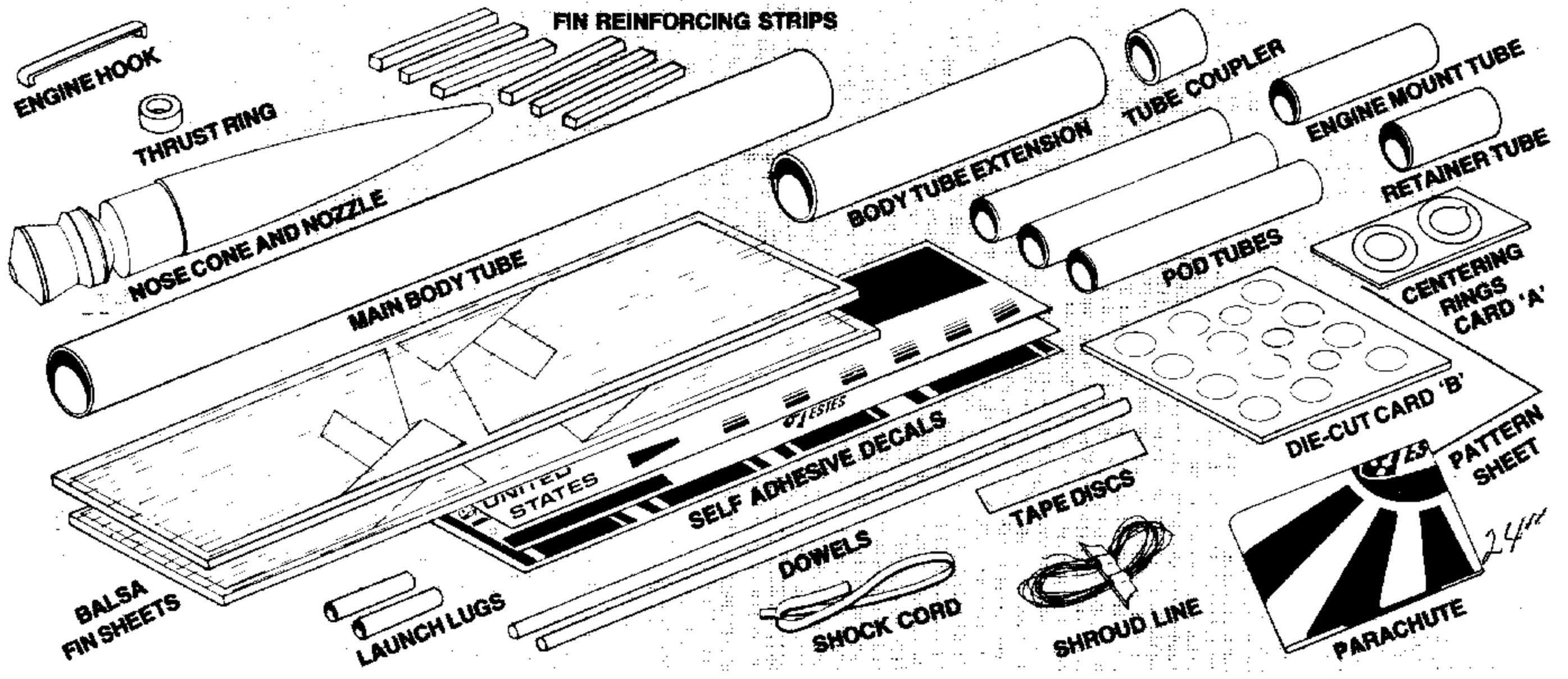

In addition to the parts included in the kit you will also need:



ROCKET ASSEMBLY

1. A. Mark engine mount tube $1\frac{3}{16}$ inches and $2\frac{1}{2}$ inches from one end. Cut a $\frac{1}{8}$ inch wide slit at the $2\frac{1}{2}$ inch mark.
- B. Bend engine hook so it has a very slight upward bow. Insert one end of hook into slit in tube.
- C. Apply a bead of glue around upper portion of engine mount tube and smear glue into an even film with finger. Slide retainer tube over front of engine mount tube and slide down to $1\frac{3}{16}$ inch mark. Make sure engine hook is parallel with tube. Wipe away excess glue.
- D. Slide the thrust ring down into tube until it is against end of engine hook. Use toothpick to apply glue around joint between ring and tube.
- E. Remove engine mount centering rings from die-cut card 'A'. Apply a bead of glue around joint between engine mount tube and rear of retainer tube. One centering ring has a small semi-circular cut-out area on the inner ring. Slide this ring onto bottom of mount with the cut-out area over the engine hook. Push the ring up against the retainer tube.
- F. Apply a bead of glue around the joint between engine mount tube and front of retainer tube. Slide remaining ring over front of mount and down against front of retainer tube. Apply a reinforcing bead of glue to both sides of both ring/tube joints.

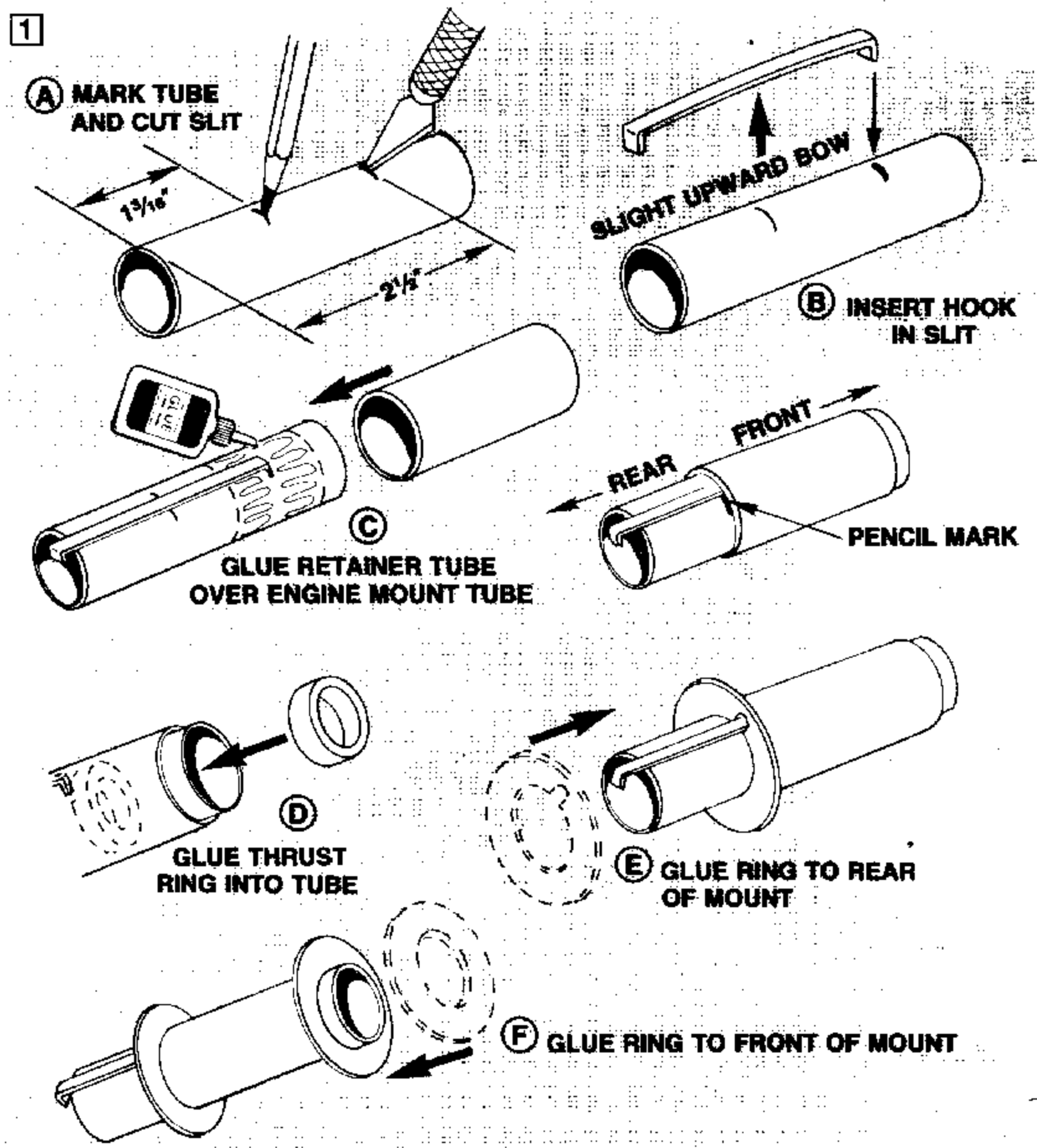

2. A. Lightly sand both sides of balsa sheets. Run knife along die-cut lines to free parts from sheets.
- B. Cut a piece from plastic parts bag and place on a flat surface. Lay a fin and fin extension on the plastic. Place the parts so they fit together as shown in the drawing. Apply a bead of glue to the edge of the extension that fits against the edge of fin. Press the pieces together. Let glue dry for awhile, then rub a film of glue over the joint. Let this glue dry, then turn assembly over and apply a film of glue to joint on that side. Glue extensions to two remaining fins in same manner.
- C. Stack like parts together and sand edges. Leave all edges square.

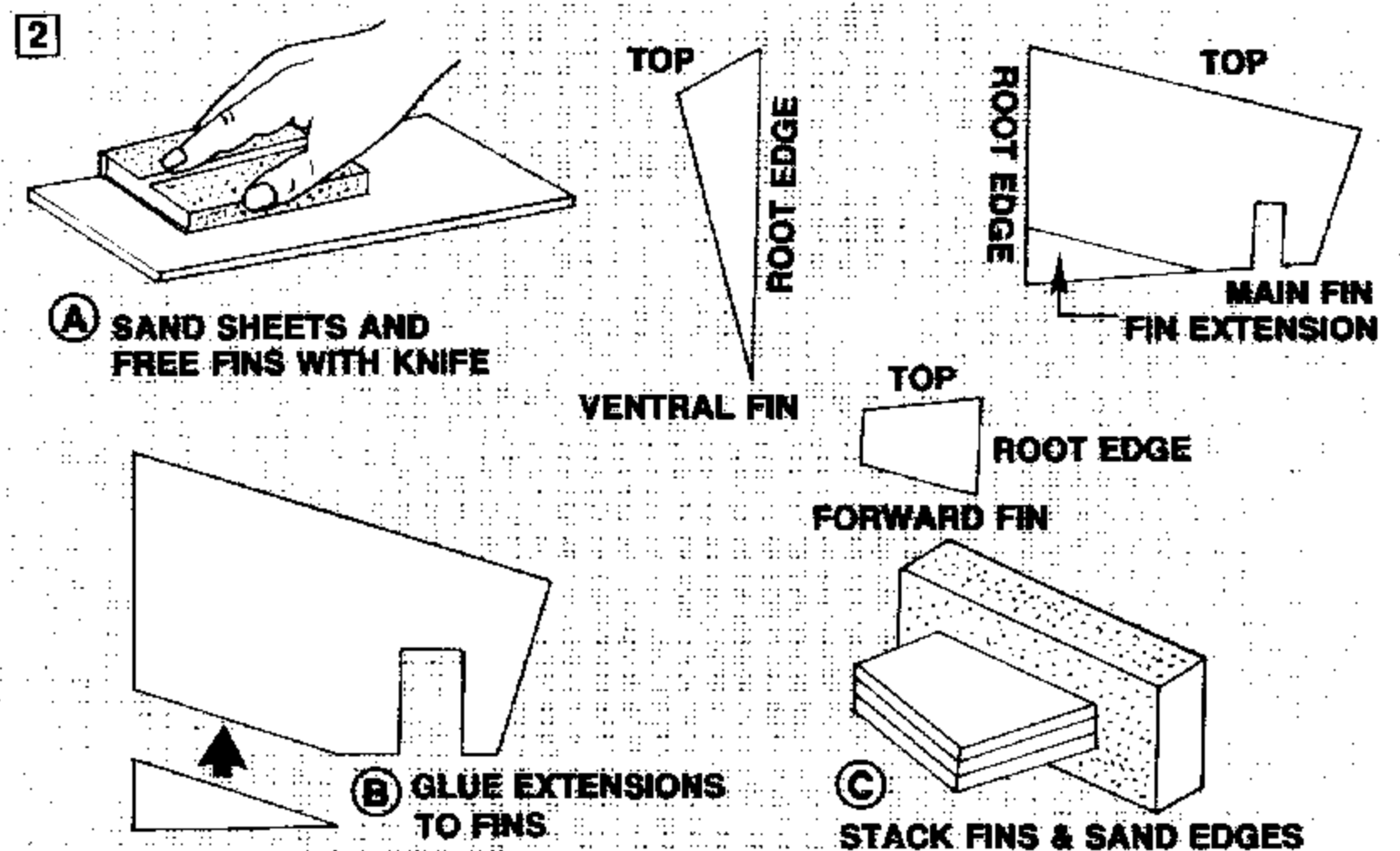

3. *Note: proceed only if glue on engine mount is completely dry.*
 - A. Test fit the engine mount into main (longest) body tube. Sand edges of rings, if necessary, so mount will slide into tube. Apply a generous bead of glue around inside of body tube about 2 inches from one end.
 - B. Slide engine mount into tube and push forward until engine mount tube extends exactly $\frac{3}{4}$ inches from end of body tube.
 - C. Apply a bead of glue to the joint between body and rear ring. Stand body on end while glue dries.

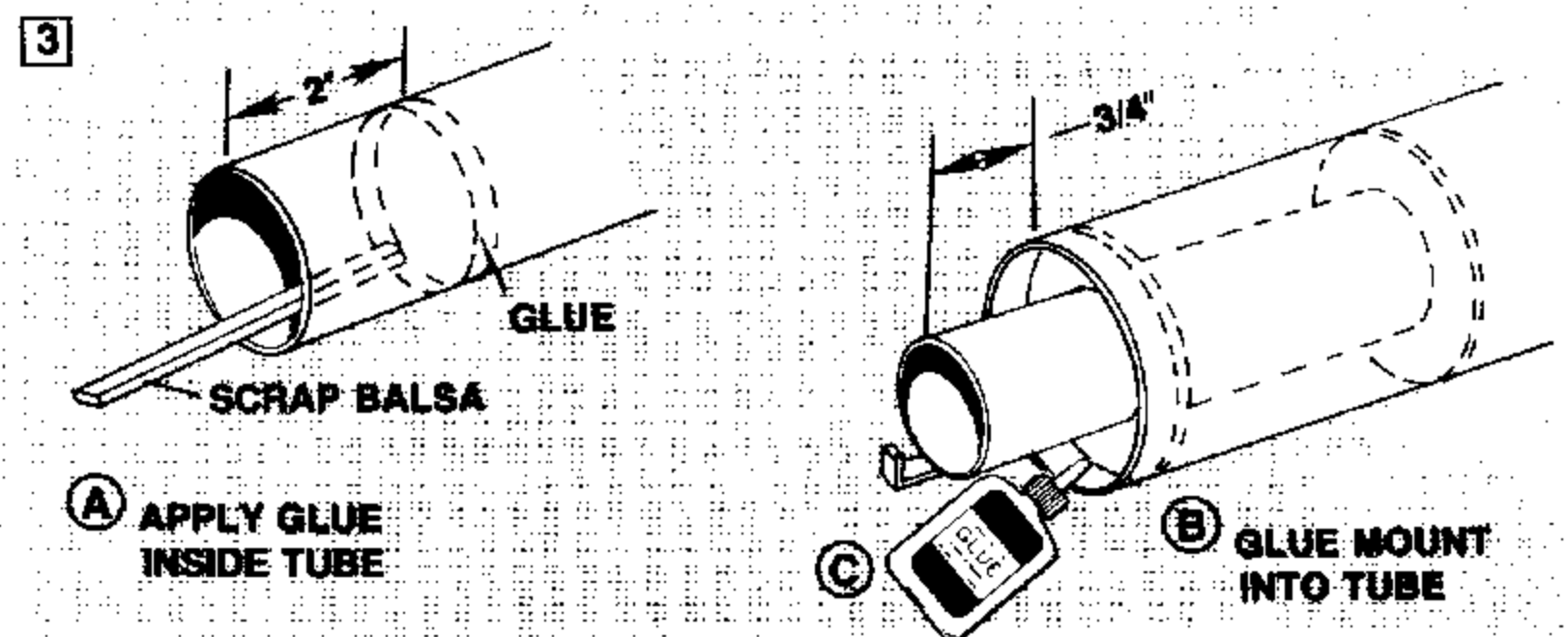

4. A. Cut the body tube marking guide from pattern sheet. Wrap guide around rear of body (the end with engine mount) and tape ends together. Mark the tube at arrow points and remove guide.
 B. Using a door frame as a drawing guide, extend lines the length of the tube at each pair of marks.
 C. Cut the pod tube marking guide from pattern sheet. Mark and draw lines on the three pod tubes using same procedure described above.

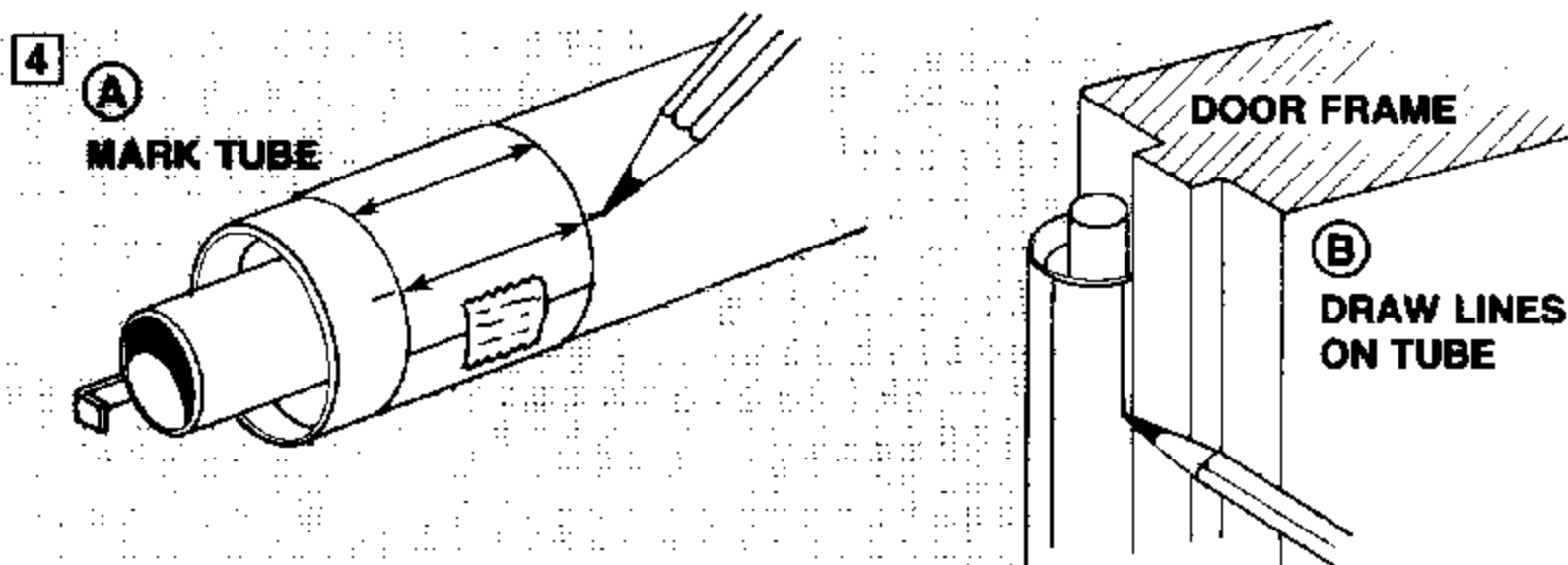

5. A. Mark tube coupler 3/4 inches from one end. Apply a bead of glue around inside of front of body tube. Smooth glue with finger and push coupler into tube until pencil mark is even with end of tube.
 B. Apply bead of glue around inside of one end of body tube extension. Smooth glue with finger and push tube onto coupler. Push tube down until end is butted against end of main body tube.

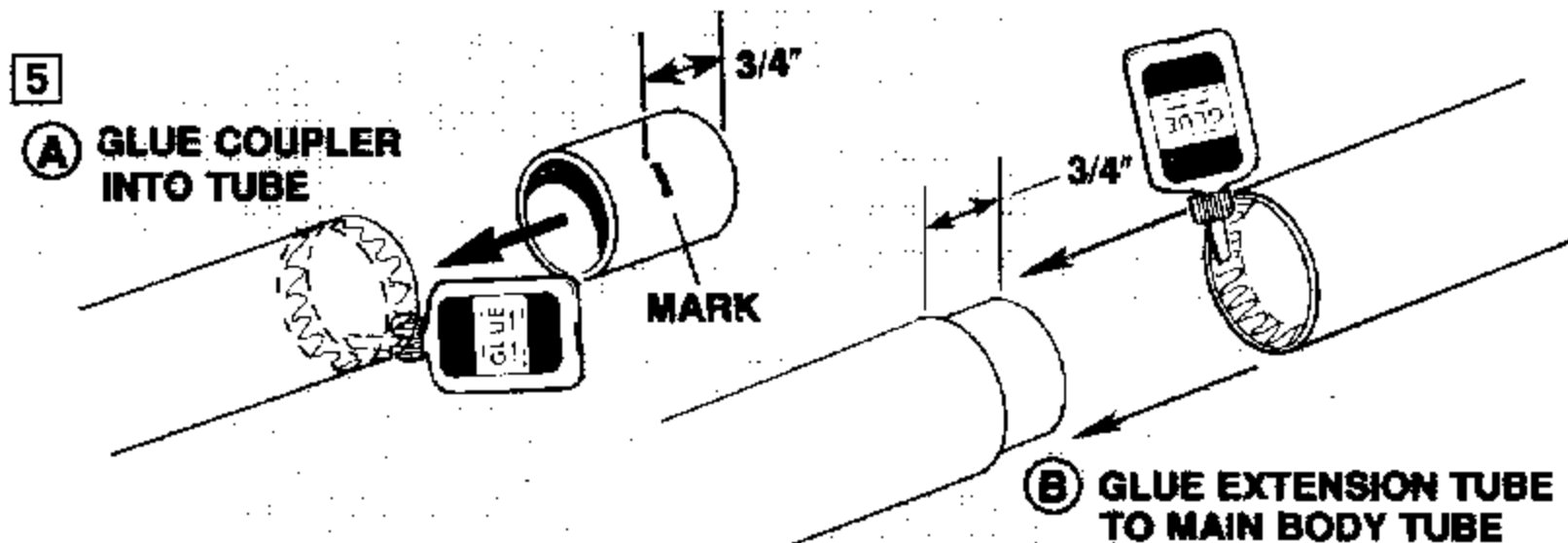

6. A. Place a mark on one of the body tube pencil lines 1 3/8 inches from rear. Place similar marks at 1 3/8 inches on every other line. Apply a bead of glue to the root edge of a main fin and attach the fin to the body, centered on the fin line, rear of fin should be at the 1 3/8 inch mark. Make sure the fin points straight out from body. Place body on table with fin pointing straight up. Place a book on front of body to keep it from rolling. Allow glue to dry.

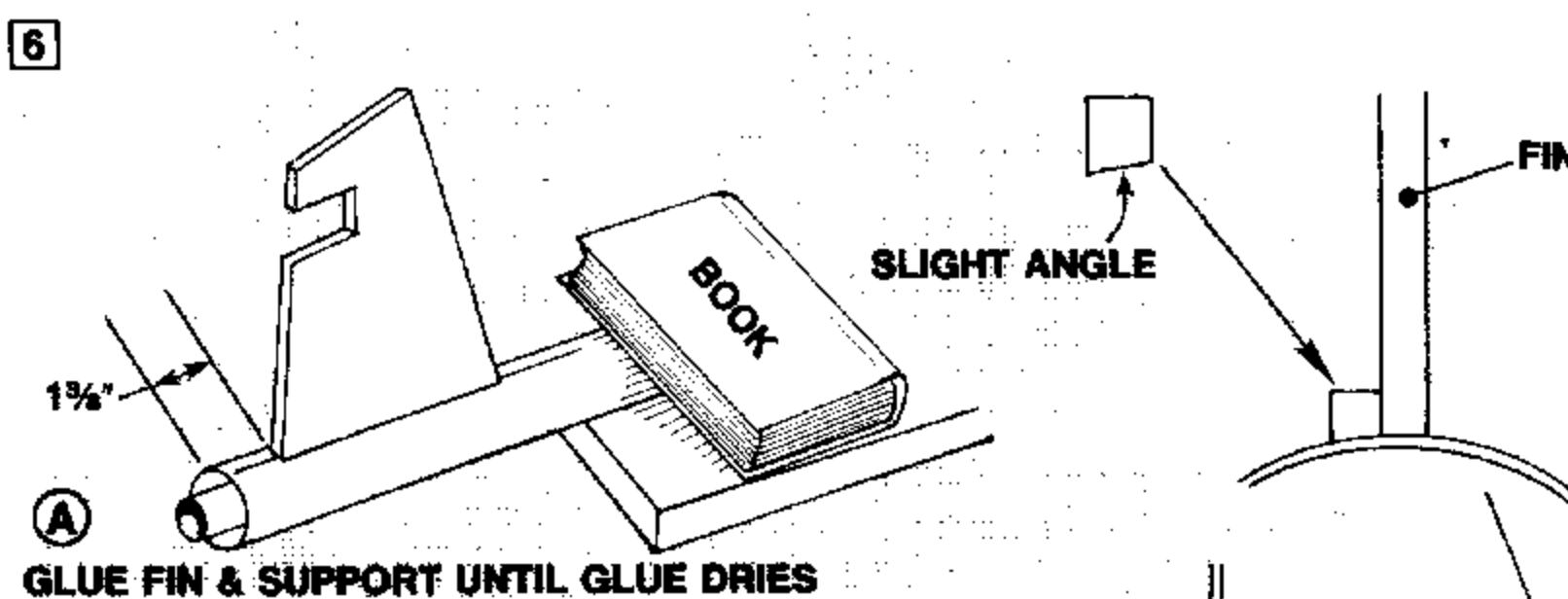

- B. Sand a slight angle to one side of a balsa fin reinforcing strip. Place strip against fin and check fit. Strip should fit well against fin and also fit against body tube. Apply glue to the edges of strip that fit against fin and body. Press strip into place. Fit and glue a second strip to other side of fin.

- C. Main fins are glued to every other pencil line. Glue second fin in place in same manner as first. It will be necessary to support assembly with fins extending off the edge of the table while glue dries. Glue reinforcing strips to the second fin, then attach the last fin and reinforcing strips in same manner.

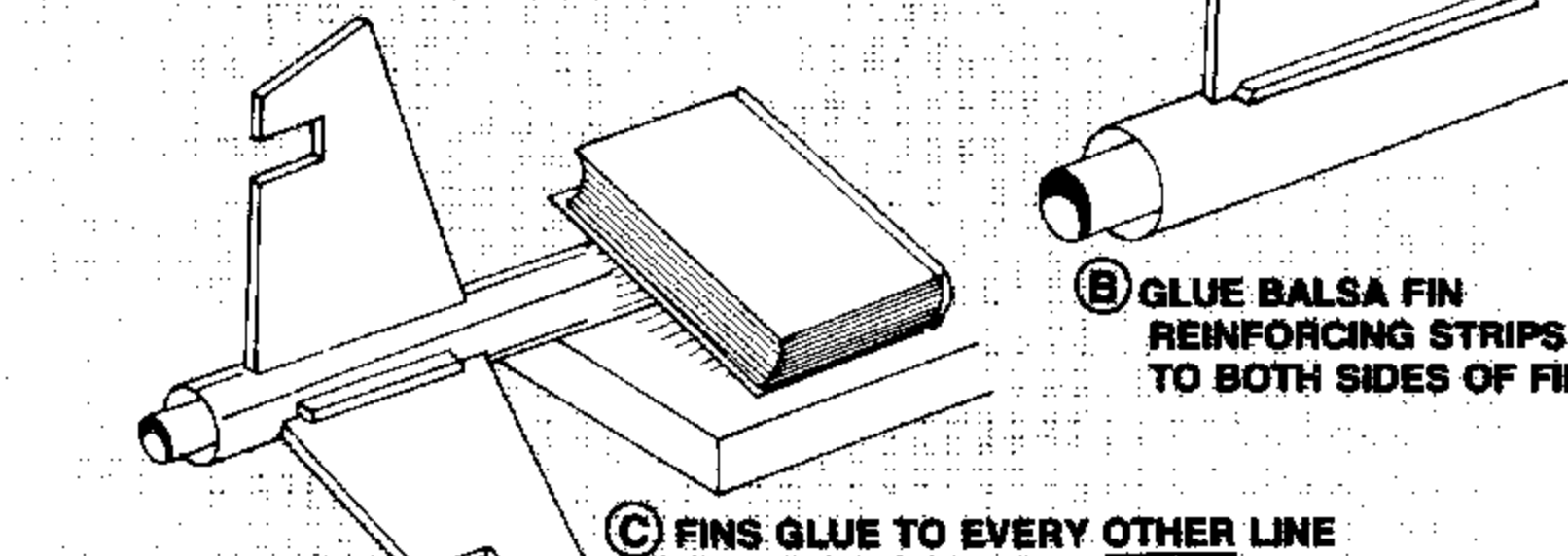

- D. The ventral fins are glued to the body, centered on the lines between the fins and with rear edges even with rear of body. As before, support body in horizontal position and allow glue to dry on one fin before attaching the next.

- E. The forward fins are glued to the same lines as the main fins, with rear edges of fins 12 inches from rear of body.

- F. When glue has dried on all parts, apply reinforcing fillets of glue to all fin/body joints and reinforcing strip/fin joints. Smooth glue with your finger. Again, support model in horizontal position while glue dries.

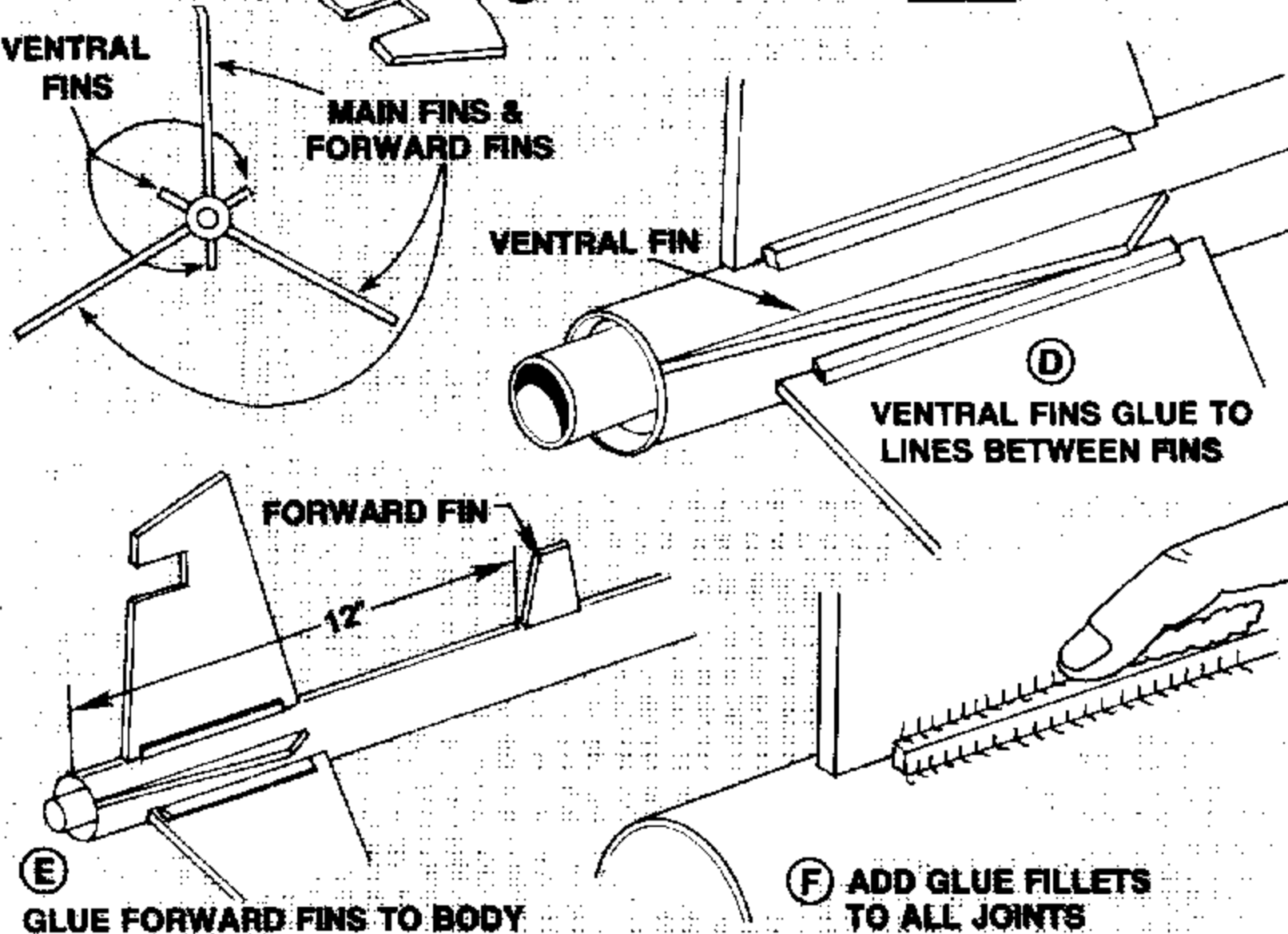

- 7.** A. Glue a launch lug to the side of one ventral fin as shown.
 B. After glue has dried, slip one of the wood dowels through the launch lug. Slide the remaining launch lug over the front of the dowel and position so that rear of lug is even with rear of forward fins. Apply a bead of glue to launch lug, then rotate it so glue is in contact with the body.
 C. After glue has dried, remove dowel. Apply reinforcing fillets of glue to both launch lugs.

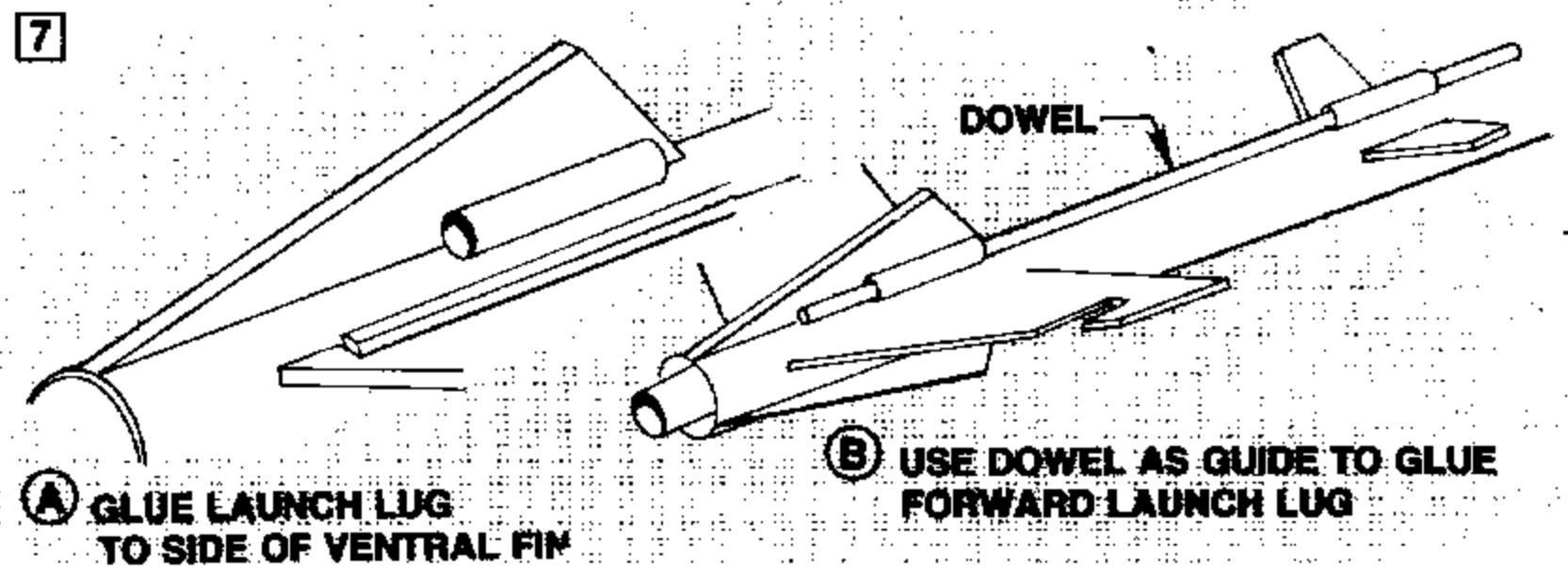

- 8.** A. Cut two $7\frac{1}{4}$ inch long pieces from one dowel and one $7\frac{1}{4}$ inch piece from the second dowel. Mark the three pieces $5\frac{3}{8}$ inches from one end.
 B. Remove the 12 rings and 3 discs from the die-cut card 'B'. Slide one ring onto a dowel, position at the $5\frac{3}{8}$ inch mark and apply a bead of glue to both sides of ring/dowel joint. Glue another ring to the end of the dowel as shown. NOTE: Study drawing to make sure this ring is glued to the correct end of the dowel. Glue 4 more rings to 2 remaining dowels in same manner.
 C. Glue 2 rings together. Make sure the edges of the rings are even. Sand a slight taper to one end of a piece of scrap dowel. Insert dowel in hole in rings and twist back and forth to remove excess glue. Remove dowel. Glue another pair of rings together, then a third in this manner. Remove excess glue from holes in rings. Glue a disc to one side of each ring assembly. These will be called the "feet" for the pod assemblies.
 D. The glue on the ring/dowel units must be completely dry before proceeding with this step. Check fit of a ring/dowel unit into a pod tube. Sand edges of rings, if necessary, so unit will slide into tube easily. Push unit through tube until front ring extends about 1 inch beyond tube. Use piece of scrap dowel to apply a bead of glue around inside of end of tube as shown. Slide unit back into tube until front ring is flush with end. Use scrap dowel to apply a bead of glue around joint between rear ring and tube. Construct two more pod assemblies in same manner.
 E. Glue a "foot" (step c) to exposed end of dowel on each pod unit. Make sure feet are square with pod units. After glue dries, apply a bead of glue to joints between "feet" and dowels.

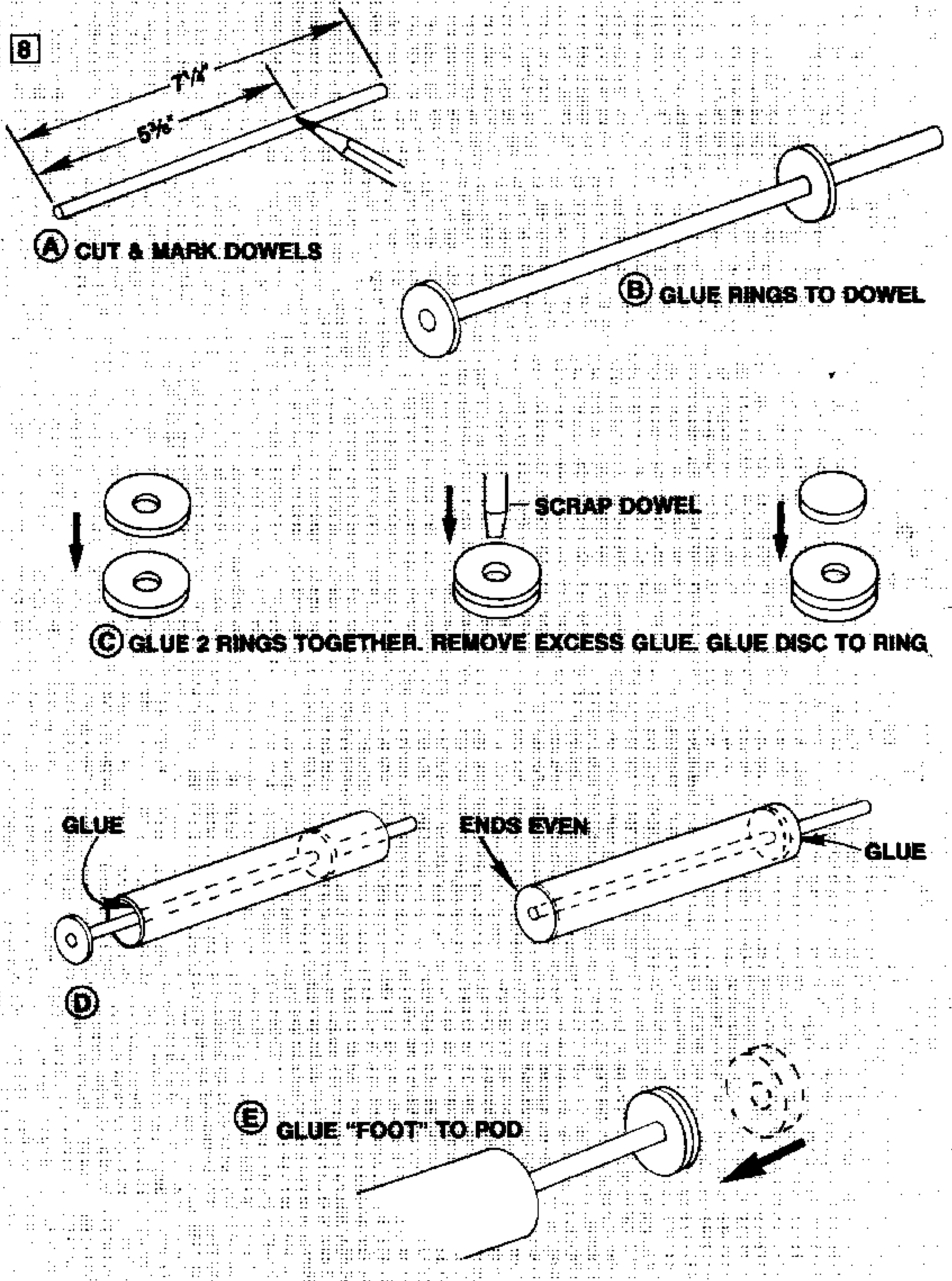

- 9.** A. Check fit a pod into slot in fin. Sand edges of fin slot, if necessary, so pod will fit. Note that lines on pod tubes are aligned with edges of fin slot.
 B. Apply glue to slot and push pod into place. Make sure pod is straight with fin and let glue dry. Glue pods into remaining fins. Apply glue fillets to joints between pods and fins. Let glue dry, then apply a second fillet of glue to form a very strong bond.

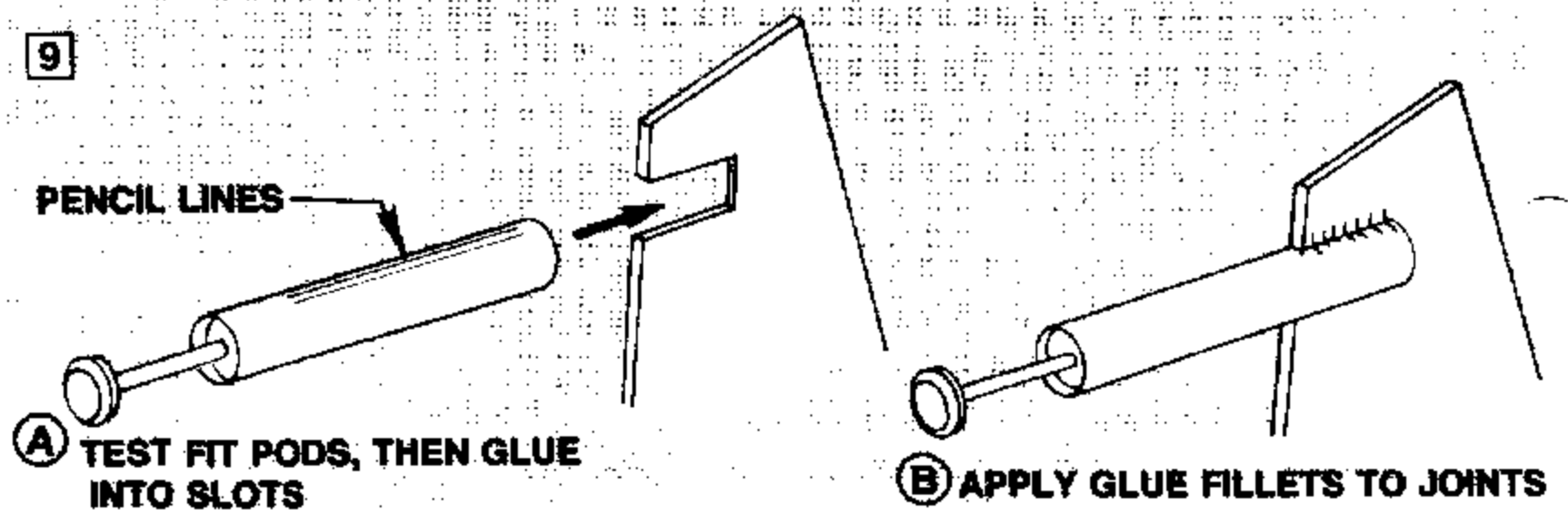

- 10.A.** Using a hobby saw, separate nose cone and nozzle units.
- B.** Remove and discard nozzle sections indicated. Sand nozzle ends smooth. Use a knife to trim any excess plastic from nose cone and to remove any flash from inside of eyelet. **NOTE:** Lay nozzle aside. It will not be installed until after model is painted.

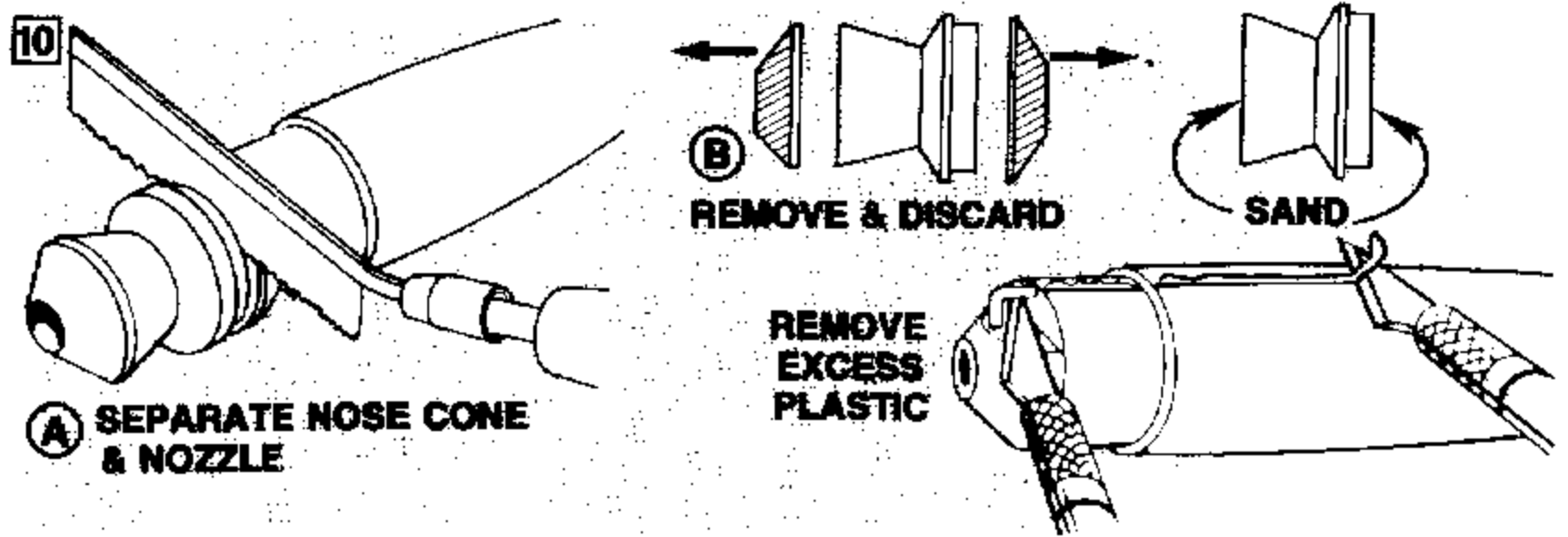

- 11.A.** Cut shock cord mount from pattern sheet.
- B.** Crease on dotted lines by folding. Spread glue on section 1 and lay end of shock cord into glue. Fold over and apply glue to back of first section and exposed part of section 2. Lay shock cord as shown and fold mount over again.
- C.** Clamp unit together with fingers until glue sets.

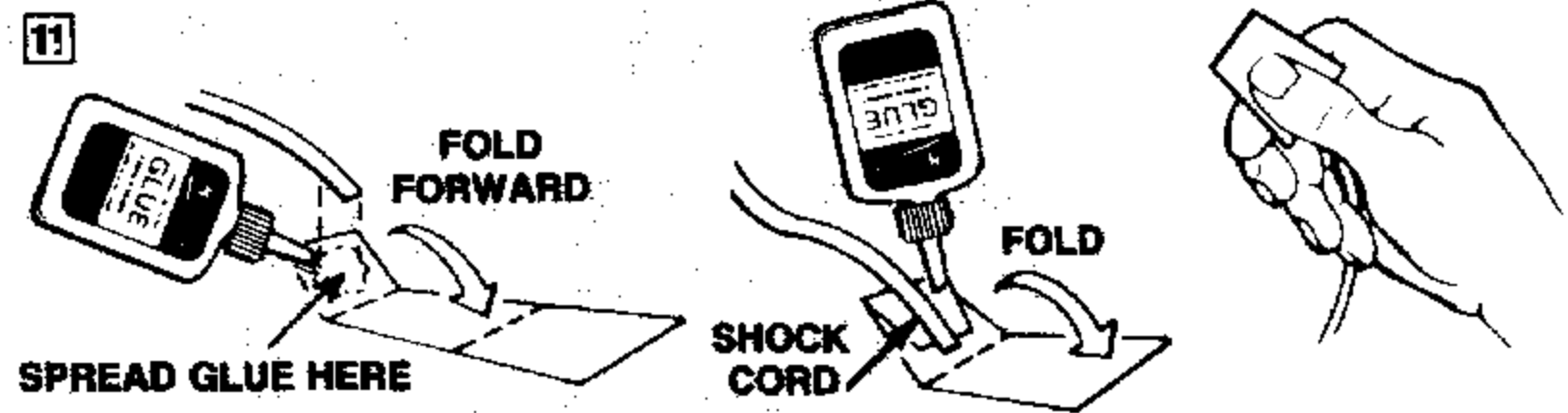

- 12.A.** Apply glue to inside front of body to cover an area no less than 1³/₄ inches to 2³/₄ inches from end. The glued area should be same size as shock cord mount.
- B.** Press mount firmly into glue as shown.
- C.** Hold until glue sets.

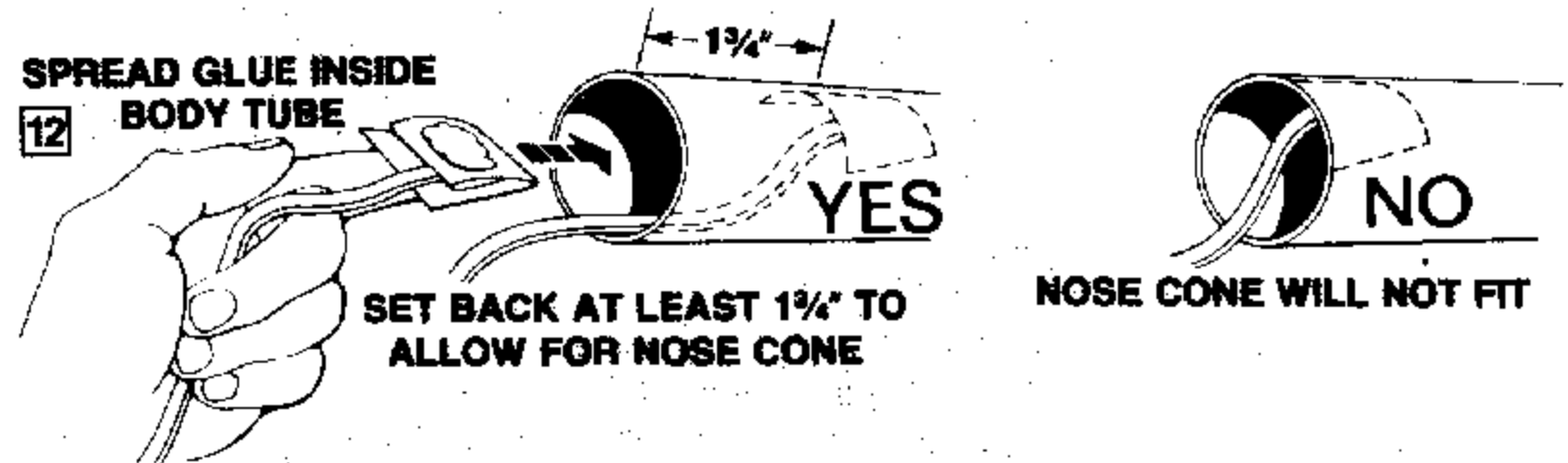

- 13.A.** Cut out parachute on edge lines.
- B.** Cut three 47 inch lengths of shroud line.
- C.** Form small loops with ends of shroud line and press onto sticky side of tape discs. Attach tape discs with line ends to top of parachute as shown.
- D.** Press tape discs firmly into place until tape discs and parachute material are molded around shroud line loops.
- E.** Pass shroud line loops through eyelet on nose cone. Pass parachute through loop ends and pull lines tight against the nose cone.
- F.** Tie free end of shock cord to nose cone eyelet. Push 'chute and shock cord into body and socket nose cone in place.

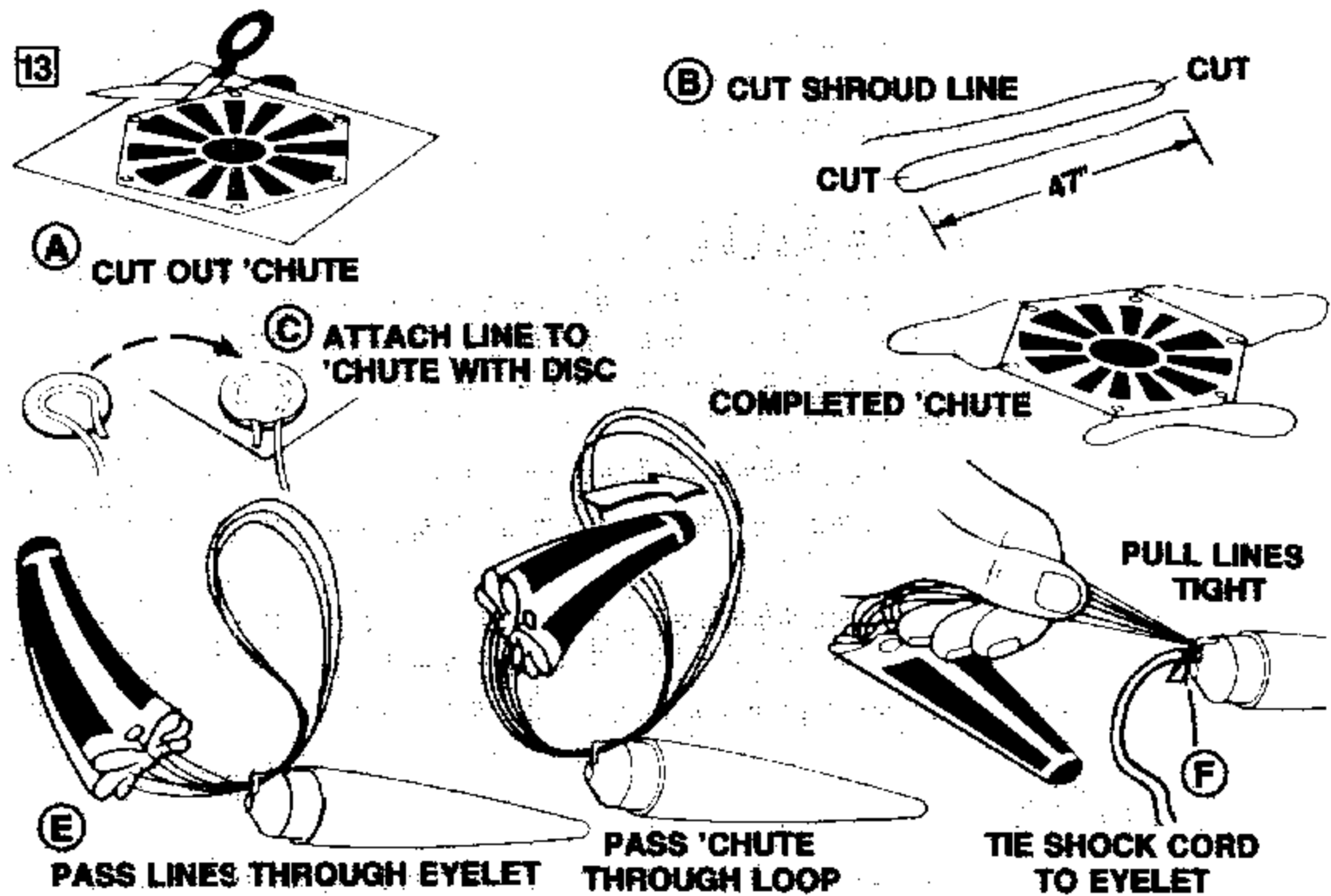

14. FINISHING THE MODEL

Seal all fins with sanding sealer, let dry, then sand. The number of times you repeat this process will have a direct bearing on the appearance of the finished model. Once the model is sealed, wipe with a damp cloth to remove sanding dust. Place the model upright on newspapers for painting. Spray the model with gloss white spray enamel. Brush paint the exhaust nozzle with gloss or flat black enamel. After paint on rocket is dry, brush paint the feet and dowels with silver enamel. Allow paint to dry overnight before applying decals.

These are self-adhesive decals. They must be cut individually from the sheets. Cut just inside the dotted black lines. It is advisable to test fit the decals before removing protective backing material. Example: The color block with large number '3' fits onto a fin. Place this decal on the fin, position it exactly where you want it, and place light pencil marks on the fin at

decal corners. Remove protective backing and, using pencil marks as a guide, place decal lightly on fin. If decal is not straight, gently remove and try again. Do not press decal down firmly until you are sure it is accurately positioned. When rubbing the decal onto the model, work from the center out, forcing air bubbles out to the edges.

Use the box art as a guide for decal locations. The fin decals have a right and left side. The number '3' is applied to both sides of one fin, the 'Vega' logo to both sides of another fin, and 'United States' to both sides of the third. The small black '3' is applied to one side only of the forward fins. The Estes logo may be applied wherever you wish.

The nozzle press fits into rear of body. Do not glue nozzle into tube. To facilitate engine installation and to prevent possible heat damage to nozzle, remove it prior to actual launch.

ROCKET PREFLIGHT

1. REMOVE PLASTIC NOZZLE.

2. CRUMPLE AND INSERT 5 OR 6 SQUARES OF RECOVERY WADDING INTO FRONT OF BODY.

3. FOLD 'CHUTE EXACTLY AS SHOWN.

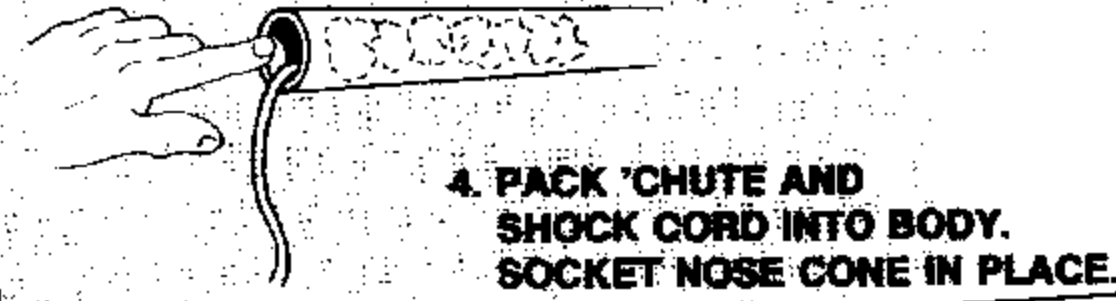
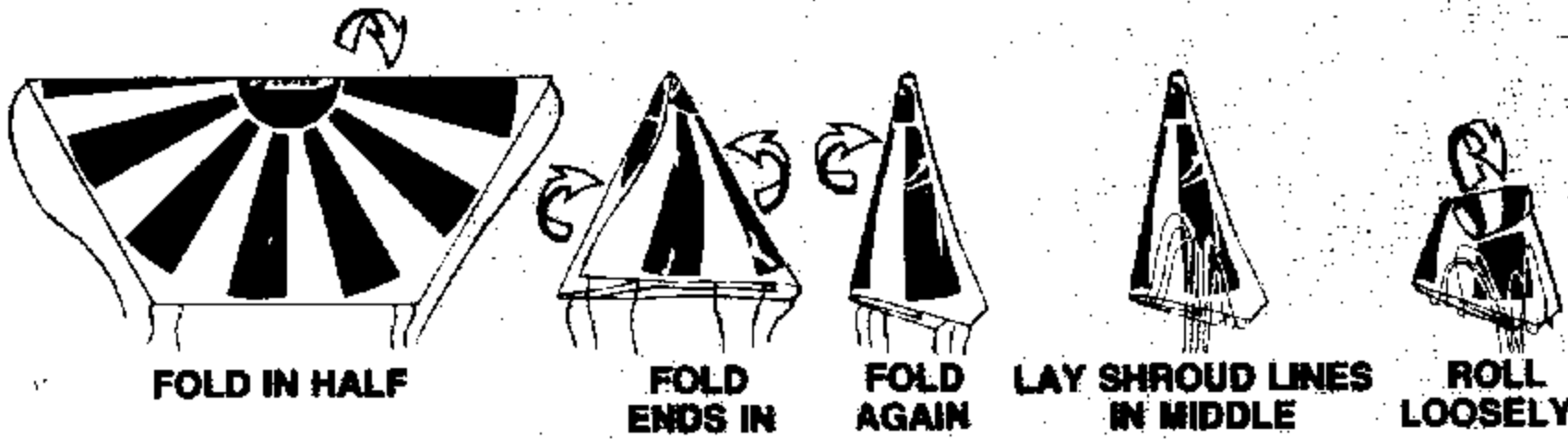

4. PACK 'CHUTE AND SHOCK CORD INTO BODY. SOCKET NOSE CONE IN PLACE.

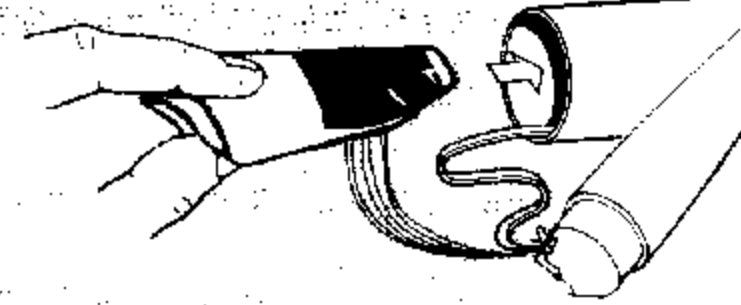

PREPARE ENGINE



SEPARATE THE IGNITERS

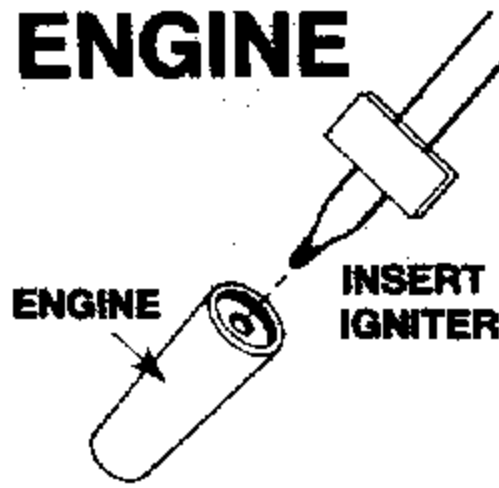

ENGINE INSERT IGNITER

IGNITER TIP MUST TOUCH PROPELLANT DEEP INSIDE NOZZLE OPENING



APPLY AND FIRMLY PRESS MASKING TAPE IN PLACE



BEND LEADS IN U SHAPES AND SPREAD

INSTALL ENGINE IN ROCKET

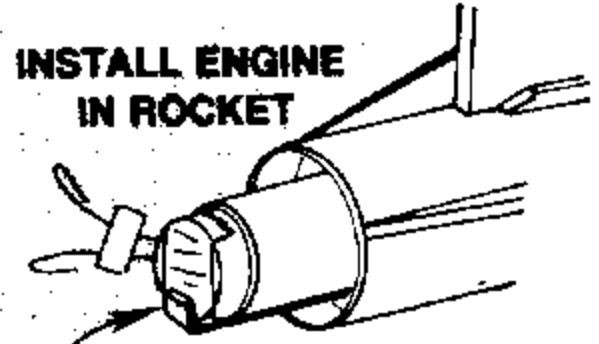

HOOK MUST LATCH SECURELY OVER END OF ENGINE

LAUNCH SUPPLIES

To launch your rocket you will need the following items:

—An Estes model rocket launching system with a heavy duty, 3/16 inch diameter by 3 foot long launch rod (Estes Maxi™-Rod #2244, sold separately).

—Estes recovery wadding No. 2274.

—Estes D12-3 engine and igniter.

Use only Estes products with this rocket.

FLYING YOUR ROCKET

Choose a large field away from power lines, tall trees, and low flying aircraft. Try to find a field at least 250 feet square. The larger the launch area, the better your chance of recovering your rocket. Football fields and playgrounds are great.

Launch area must be free of dry weeds and brown grass.

Launch only during calm weather with little or no wind and good visibility.

Don't leave parachute packed more than a minute or so before launch during cold weather [colder than 40° Fahrenheit (4° Celsius)].

Parachute may be dusted with talcum powder to avoid sticking.

MISFIRES

Failure of the model rocket engine to ignite is nearly always caused by incorrect igniter installation. An Estes igniter will function properly even if the coated tip is chipped. However, if the coated tip is not in direct contact with the engine propellant, it will only heat and not ignite the engine.

When an ignition failure occurs, remove the safety key from the launch control system and wait one minute before approaching the rocket. Remove the expended igniter from the engine and install a new one. Be certain the coated tip is in direct contact with the engine propellant, then tape the igniter leads firmly to base of engine as illustrated above. Repeat the countdown and launch procedure.

FOR YOUR SAFETY AND ENJOYMENT

Always follow the NAR-HIA* MODEL ROCKETRY SAFETY CODE while participating in any model rocketry activities.

*National Association of Rocketry-The Hobby Industry of America

COUNTDOWN AND LAUNCH

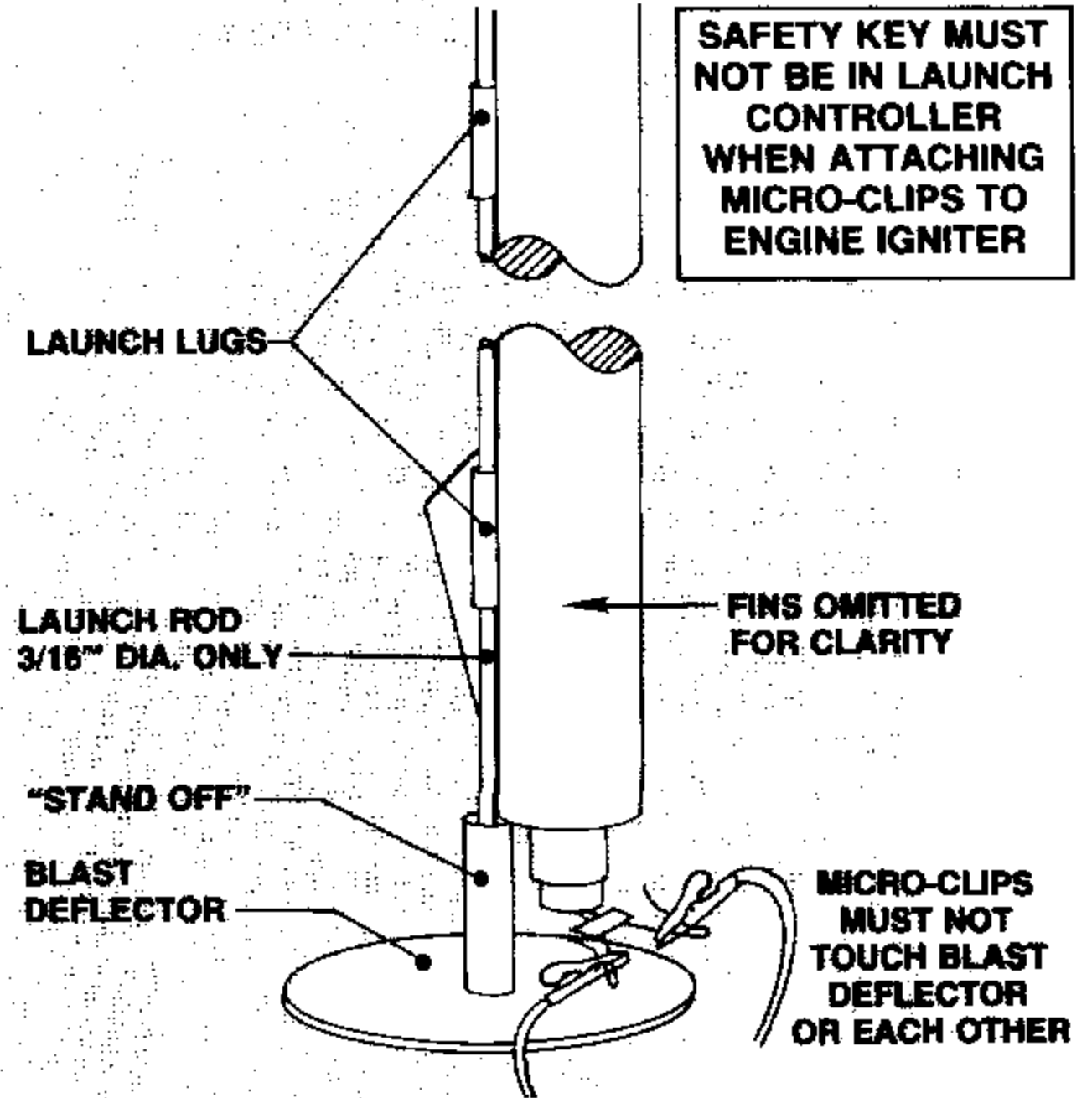

SAFETY KEY MUST NOT BE IN LAUNCH CONTROLLER WHEN ATTACHING MICRO-CLIPS TO ENGINE IGNITER

- ⑩ BE CERTAIN SAFETY KEY IS NOT IN LAUNCH CONTROLLER.
- ⑨ Remove safety cap and slide launch lugs over launch rod to place rocket on launch pad. Make sure the rocket slides freely on the launch rod.
- ⑧ Attach micro-clips to the igniter wires. Arrange the clips so they do not touch each other or the metal blast deflector. Attach clips as close to protective tape on igniter as possible.
- ⑦ Move back from your rocket as far as launch wire will permit (at least 15 feet).
- ⑥ INSERT SAFETY KEY to arm the launch controller.
Give audible countdown 5...4...3...2...1

LAUNCH!! PUSH AND HOLD LAUNCH BUTTON UNTIL ENGINE IGNITES
REMOVE SAFETY KEY FROM LAUNCH CONTROLLER.
REPLACE SAFETY KEY AND SAFETY CAP ON LAUNCH ROD.