

# SCRAMBLER™

FLYING MODEL ROCKET



#2072



ESTES INDUSTRIES  
1295 H Street  
Penrose, CO 81240 USA

## PARTS AND SUPPLIES

Locate the parts shown below and lay them out on the table in front of you.

## ASSEMBLY TIP

Read all instructions before beginning work on your model. Make sure you have all parts and supplies. Test-fit all parts together before applying any glue. If any parts don't fit properly, sand as required for precision assembly.

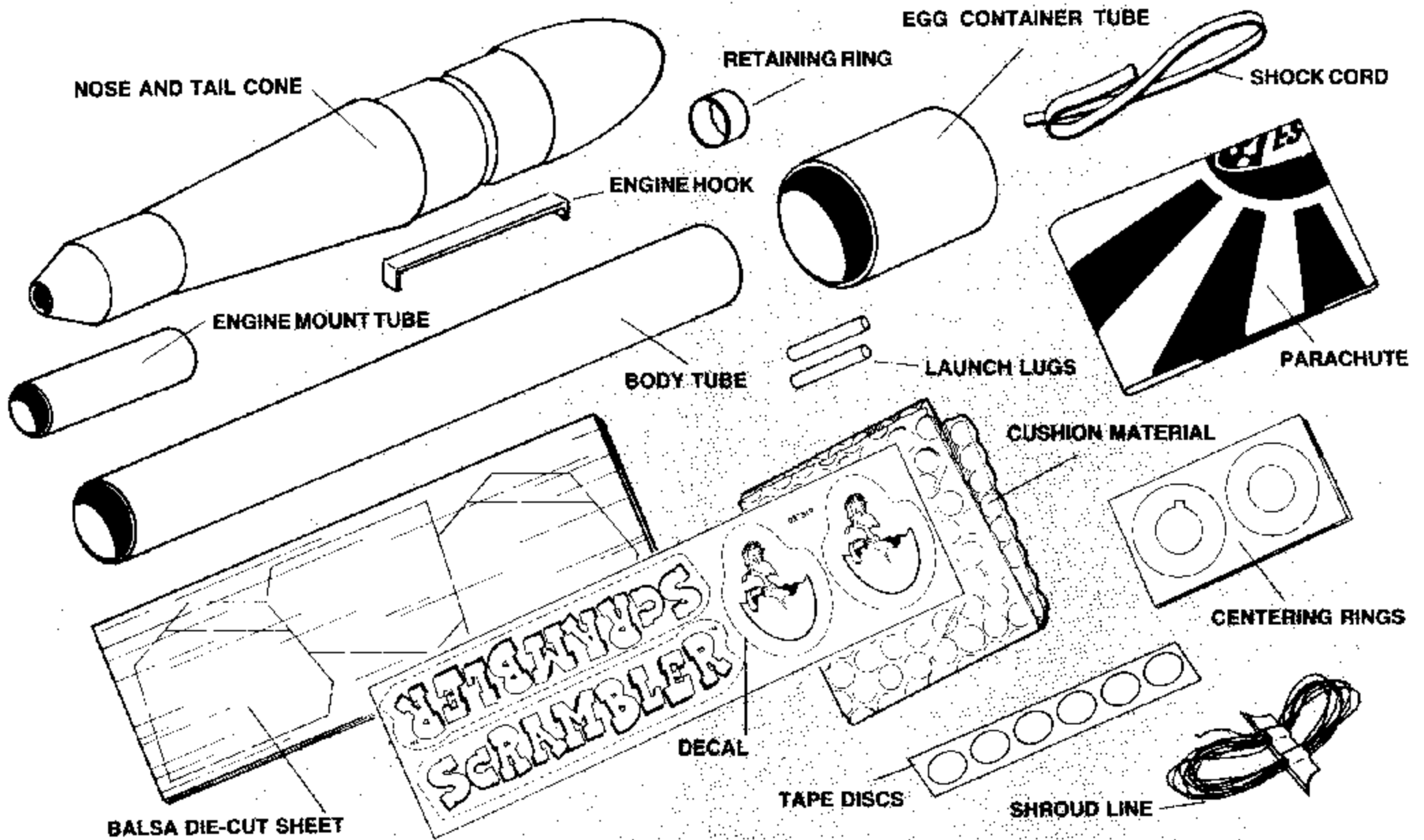

In addition to the parts included in the kit you will also need:

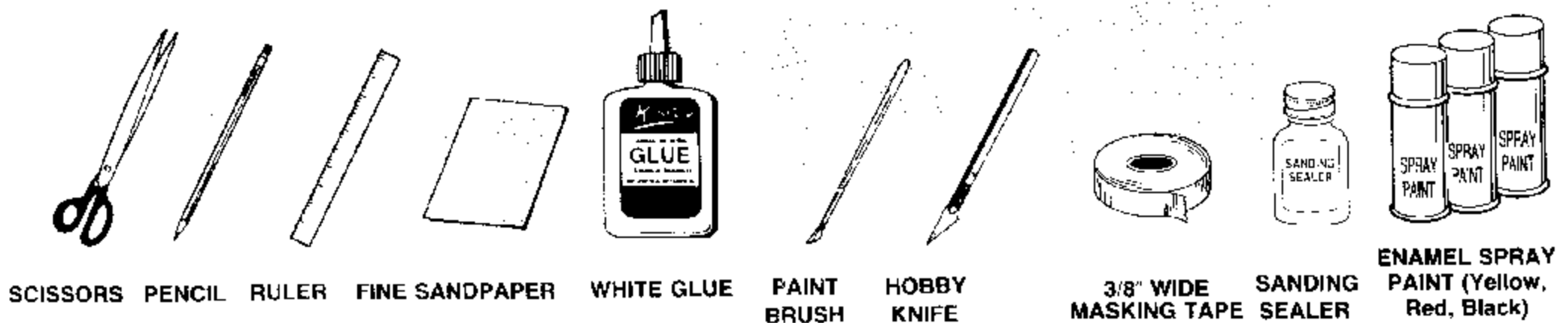

# ROCKET ASSEMBLY

**1**

- Mark engine mount tube 1 inch and 2½ inches from one end. Cut 1/8 inch long slit at 2½ inch mark.
- Insert one end of engine hook into slit. Make sure hook runs straight along tube.
- Apply a bead of glue around tube just above the 1 inch mark. Slide retaining ring over end of tube and push down to the 1 inch mark.
- Smear a film of glue over the upper portion of the engine hook.

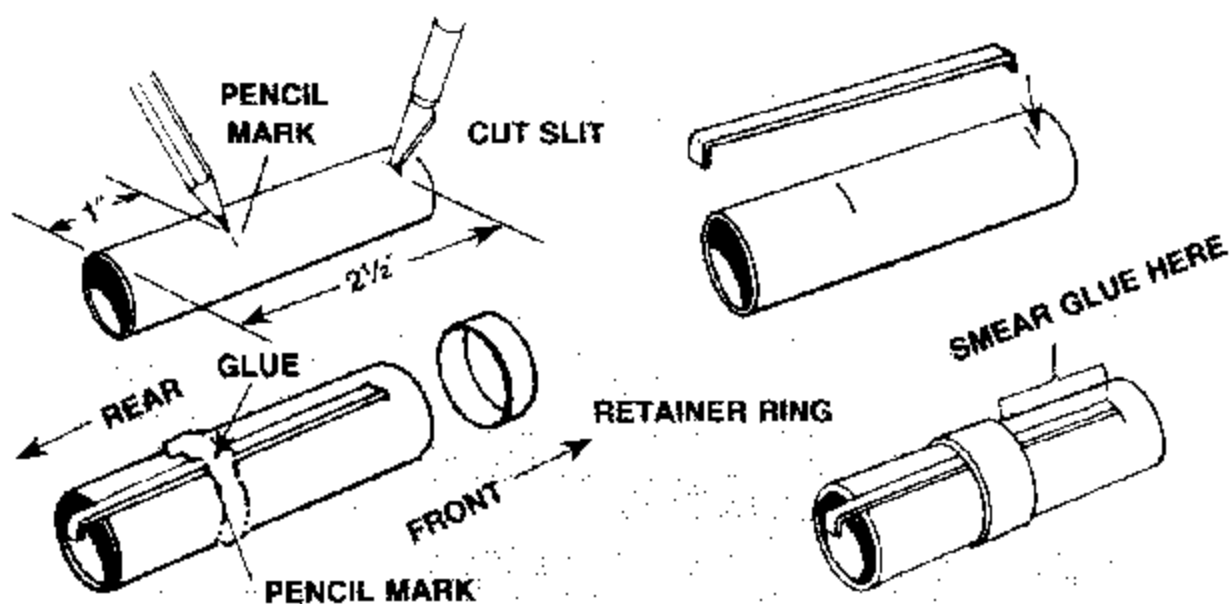

**2**

- Slide the notched centering ring onto the rear of the tube with the notch over the engine hook. Slide the other ring onto the front of the tube.
- Position the rings so they are 1/16 inch from the ends of the tube. Apply a bead of glue to both sides of each ring/body joint.
- Make sure the rings are perpendicular to the body. **DO NOT PROCEED WITH NEXT STEP UNTIL GLUE IS COMPLETELY DRY.**

NOTCHED RING

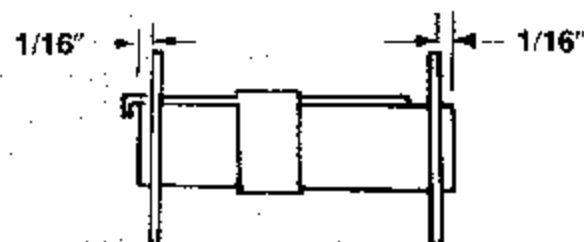
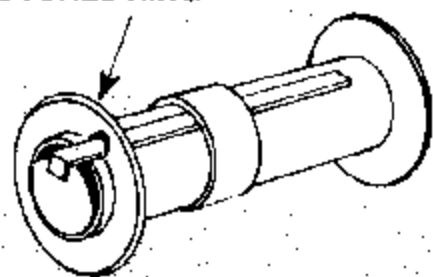

GLUE RINGS IN PLACE

**3**

- Check fit of mount in 12 inch long body tube. If necessary, sand inside edge of tube and outside edges of rings to obtain a good fit.
- Apply a bead of glue around inside of body tube 2 inches from end. Make sure end with engine hook is pointing out and slide mount into tube. Push forward until ends of tubes are even.
- Apply a bead of glue around the joint between the ring and body tube. Place the tube on its top end and allow glue to dry.

ENGINE HOOK EXTENDS THIS END

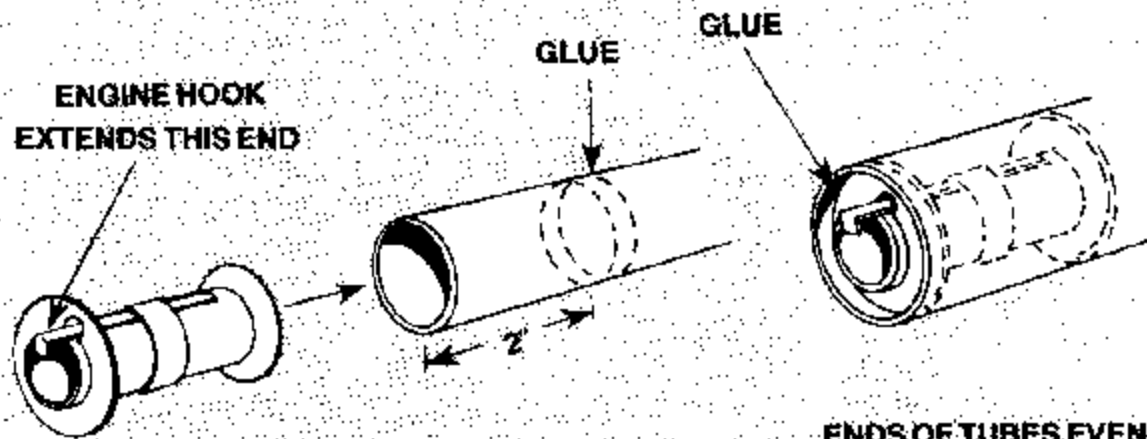

ENDS OF TUBES EVEN

**4**

- Cut the body marking guide from page 5 of these instructions. Wrap the guide around rear of body and tape ends together.
- Rotate guide so the launch lug line is aligned with the engine hook. Mark the body at each of the arrow points, then remove guide.
- Using a door frame as a guide, draw lines on the body at the marks. Fin lines should extend from the rear of the body forward about 3 inches. The launch lug line should extend the entire length of the body.

ARROW POINTS

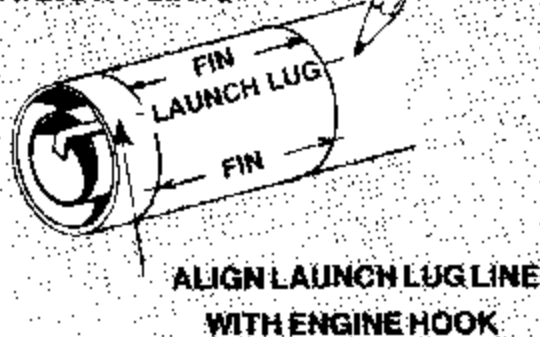

ALIGN LAUNCH LUG LINE WITH ENGINE HOOK

DOOR FRAME

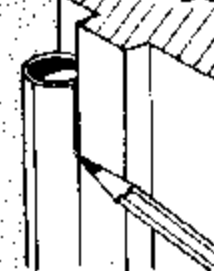

DRAW LINES ON TUBE

SAND SHEET

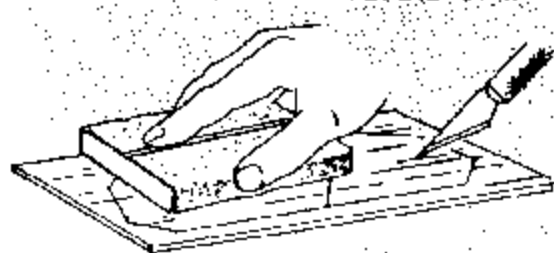

FREE FINS WITH KNIFE

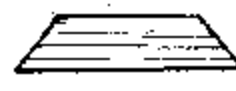

TWO LAUNCH LUG STAND-OFFS



THREE FINS

## 6

- Apply glue to the root edge of a fin. Attach the fin to the body with the fin centered on a fin line. Make sure the fin extends straight out from the body.
- Support the rocket as shown, with the fin extending straight up, until glue is completely dry.
- Attach the remaining fins in the same manner. Be sure to allow glue to dry on one fin before attaching the next fin.

**FINS MUST BE ATTACHED CORRECTLY FOR STABLE FLIGHT**

## 7

- Place marks on the launch lug line 4 inches and 9 inches from the rear of the body. Glue the launch lug stand-offs to the body as shown. Make sure both stand-offs extend straight from the body and allow glue to dry.
- You will need to use the launch rod from your rocket launch system in completing this step. If you do not have a launcher, you may wish to purchase one. You will need one to launch this rocket. Apply a bead of glue to the top of each stand-off. Slide the launch lugs onto the launch rod. Align the lugs with the stand-offs and glue in place. Support in a horizontal position and leave the launch rod in place until the glue dries.

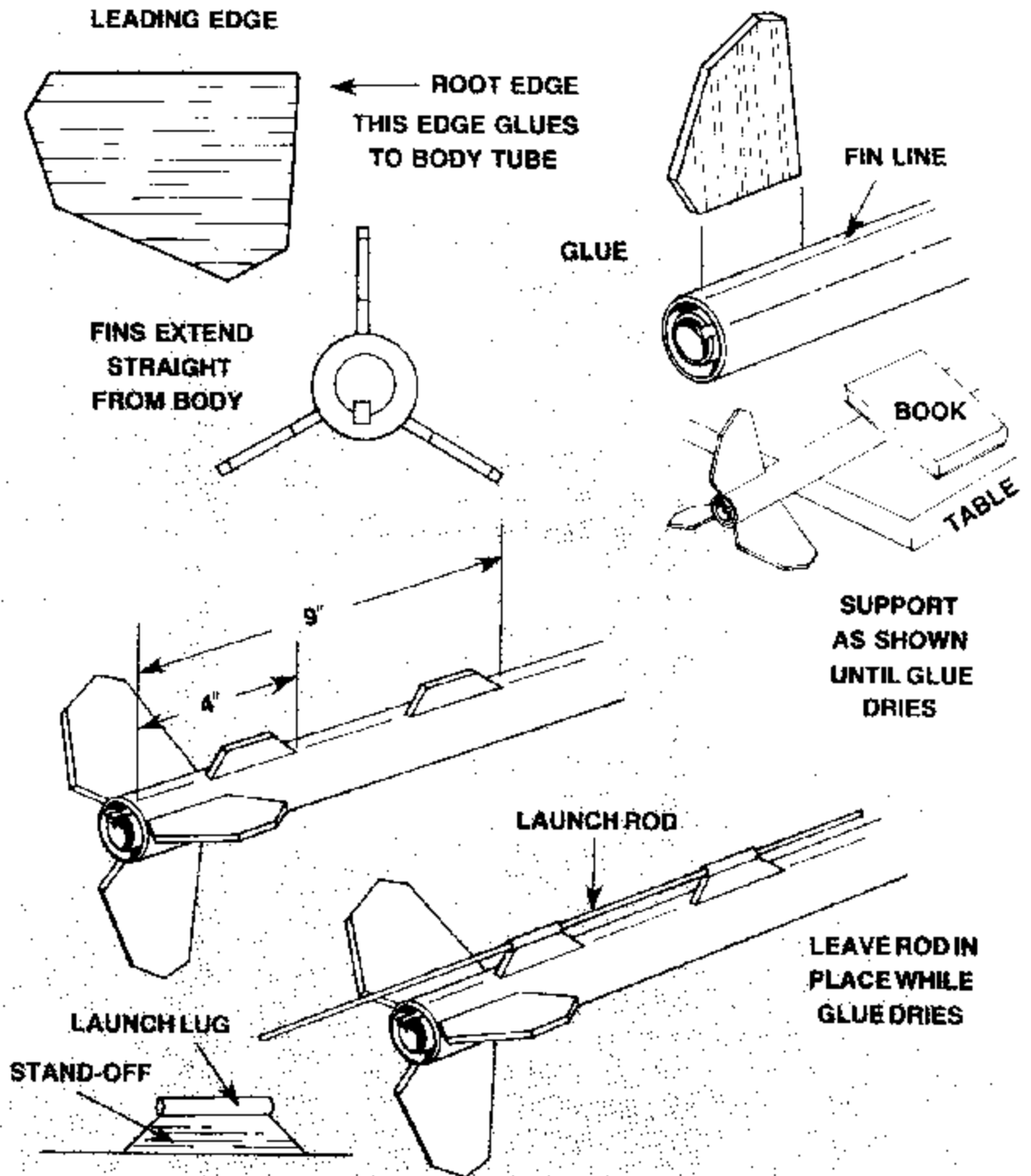

## 8

- Apply a light bead of glue to one side of a fin/body joint. Pull your finger down the joint to smooth the glue and to remove excess glue.
- Repeat this process on both sides of all fin/body joints and the launch lug/stand-off and stand-off/body joints. Support the rocket in a horizontal position until the glue dries.

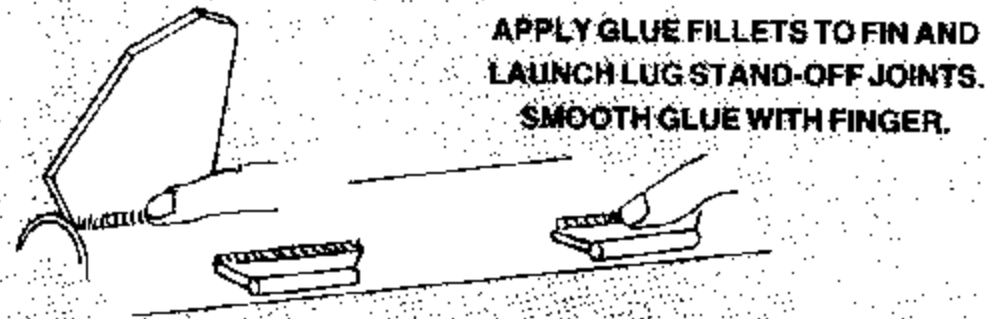

## 9

- Cut shock cord mount from page 5 of the instructions.
- Crease on dotted lines by folding. Spread glue on section 1 and lay end of shock cord into glue. Fold over and apply glue to back of first section and exposed part of section 2. Lay shock cord as shown and fold mount over again.
- Clamp unit together with fingers until glue sets.

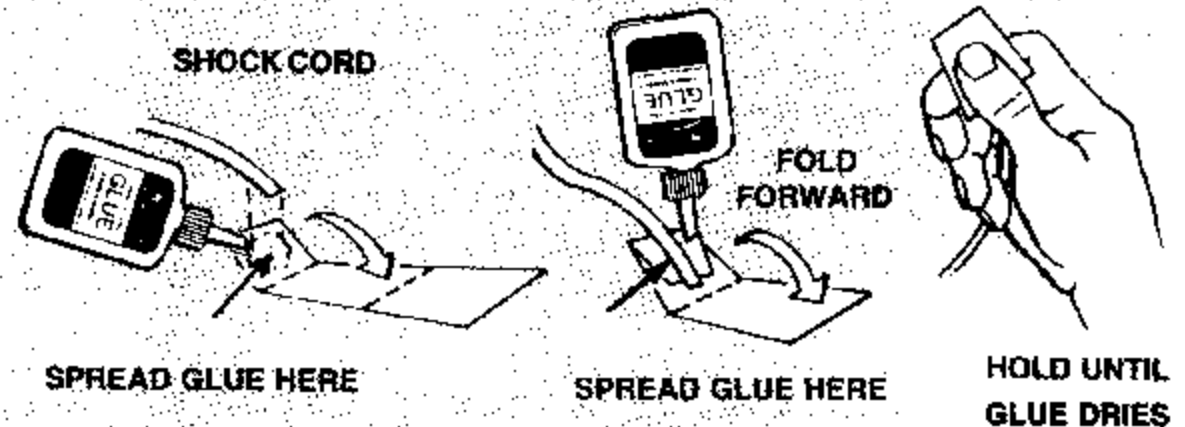

## 10

Apply a film of glue inside the front of the body at least 1 1/2 inches from the end. The glue area must be at least as large as the shock cord mount. Press the shock cord mount into the glue, molding the mount with your finger to fit the contour of the tube. After the glue is dry, smear a film of glue over the mount and surrounding body area.



**11**

Make sure the glue fillets on the fins are completely dry before proceeding with this step.

Brush a coat of sanding sealer on all exposed surfaces of the fins and stand-offs. Let sealer dry, then lightly sand. Repeat the sealing and sanding process until balsa grain lines are filled and parts feel smooth.

**12**

Tuck the shock cord down into the body. Roll up a piece of paper and insert into the engine mount for a painting holder. Spray the rocket yellow. Also paint the short egg container body tube red at this time. Set these parts aside and allow paint to dry before touching them. NOTE: The yellow nose cone and yellow adapter cone do not need painting. When yellow paint has hardened, mask off the forward end, and paint the fin unit black.

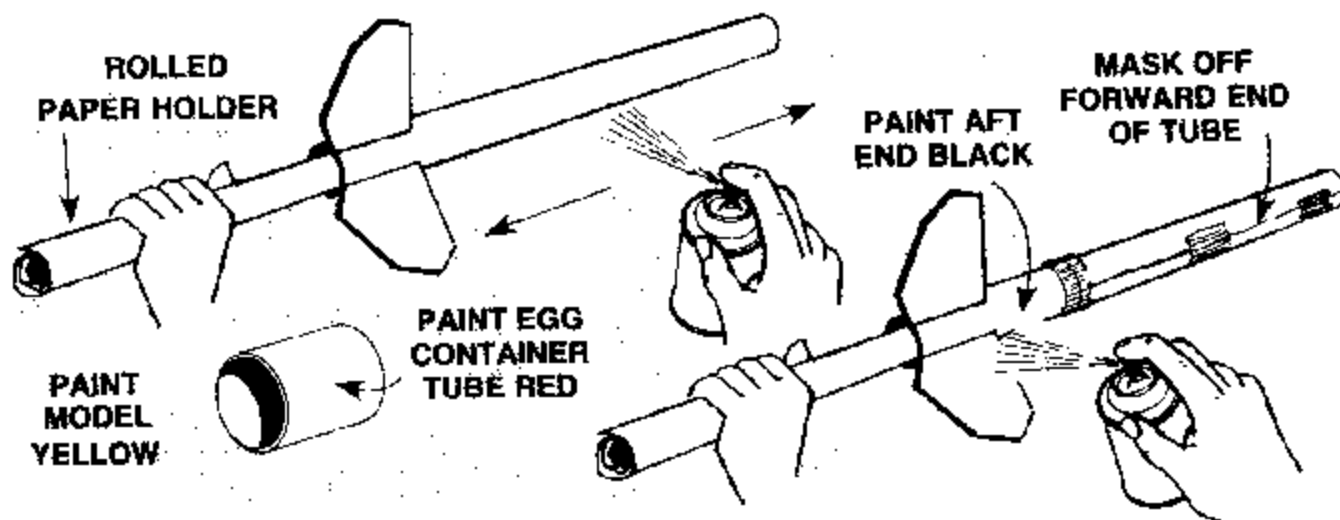
**13**

- Cut out parachute on edge lines.
- Cut three 35 inch lengths of shroud line.
- Form small loops with shroud line ends and press onto sticky side of tape discs. Attach tape discs with line ends to top of parachute as shown. Firmly press tape discs into place until both tape discs and parachute material are molded around shroud line loops.

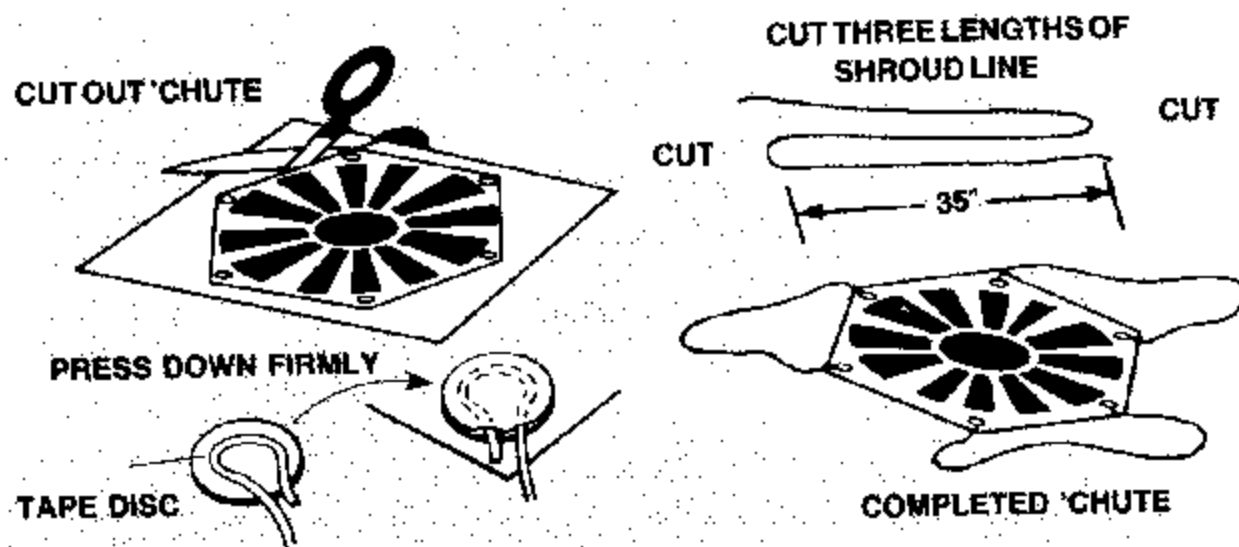
**14**

- Run the blade of a knife around the groove between the nose and tail cone. Use several light cuts to separate the parts.
- Scrape with a knife blade or sand with fine sandpaper to remove any irregular plastic flash from the part lines.
- Use the tip of the knife blade to clear the thin bit of plastic from the center of the eyelet in the tail cone.
- Socket the egg container tube onto the tail cone and socket the nose cone into the container tube.

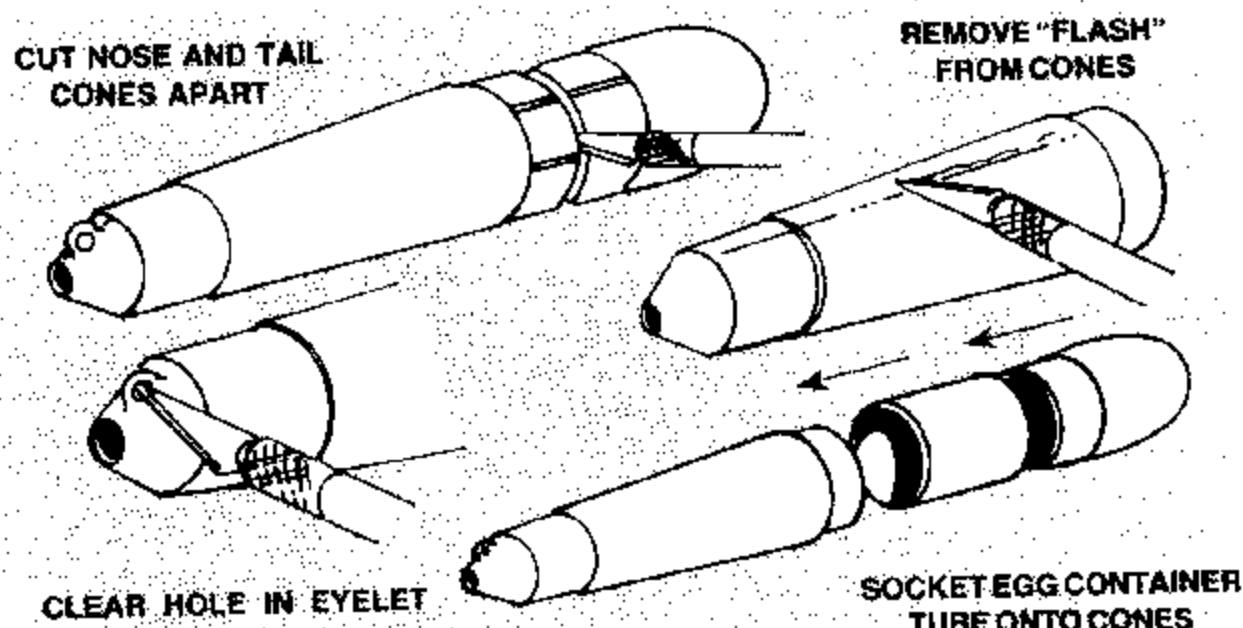
**15**

- Pass parachute shroud line loops through eyelet on tail cone.
- Pass 'chute through loops in shroud lines.
- Pull lines tight.
- Tie the end of the shock cord to the adapter cone eyelet. Tie a double knot.

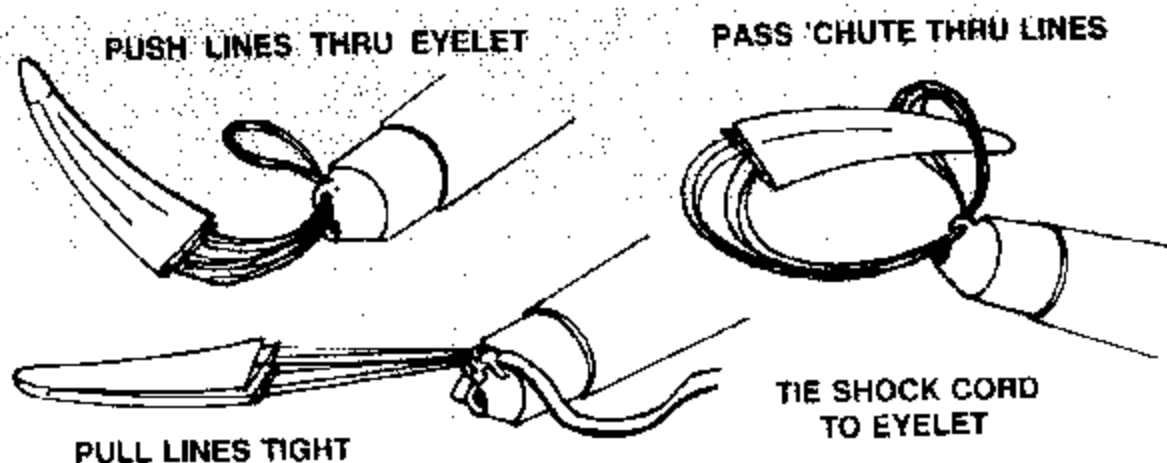

For decal placement, refer to the photo on the front of the instruction. To apply, cut out each decal from the decal sheet with a hobby knife just inside the dotted lines, and lay it gently into position. If position is correct, rub it down with your fingers to remove bubbles and stick it securely.

## PREPARING THE EGG LOFTING PORTION FOR FLIGHT

This model can accommodate eggs from "small" through "large AA size". When packing an egg for flight, follow these instructions closely.

- Lay the egg on the square of cushion material included in this kit.
- Wrap the cushion around the egg and tape ends together.
- Fold the ends of the cushion over and tape together.
- Place the egg into the body compartment and socket nose cone in place.
- IMPORTANT.** Wrap strips of 3/8 inch wide tape around the seams between the egg tube and nose and adapter cones. When recovering the egg after launch, only the tape around the nose cone seam must be removed. The only time you may need to remove the tape from the tail cone seam would be to clean the parts if an egg accidentally breaks. **NOTE:** Ordinarily, even if an egg broke, the egg mess would be contained within the plastic cushion.

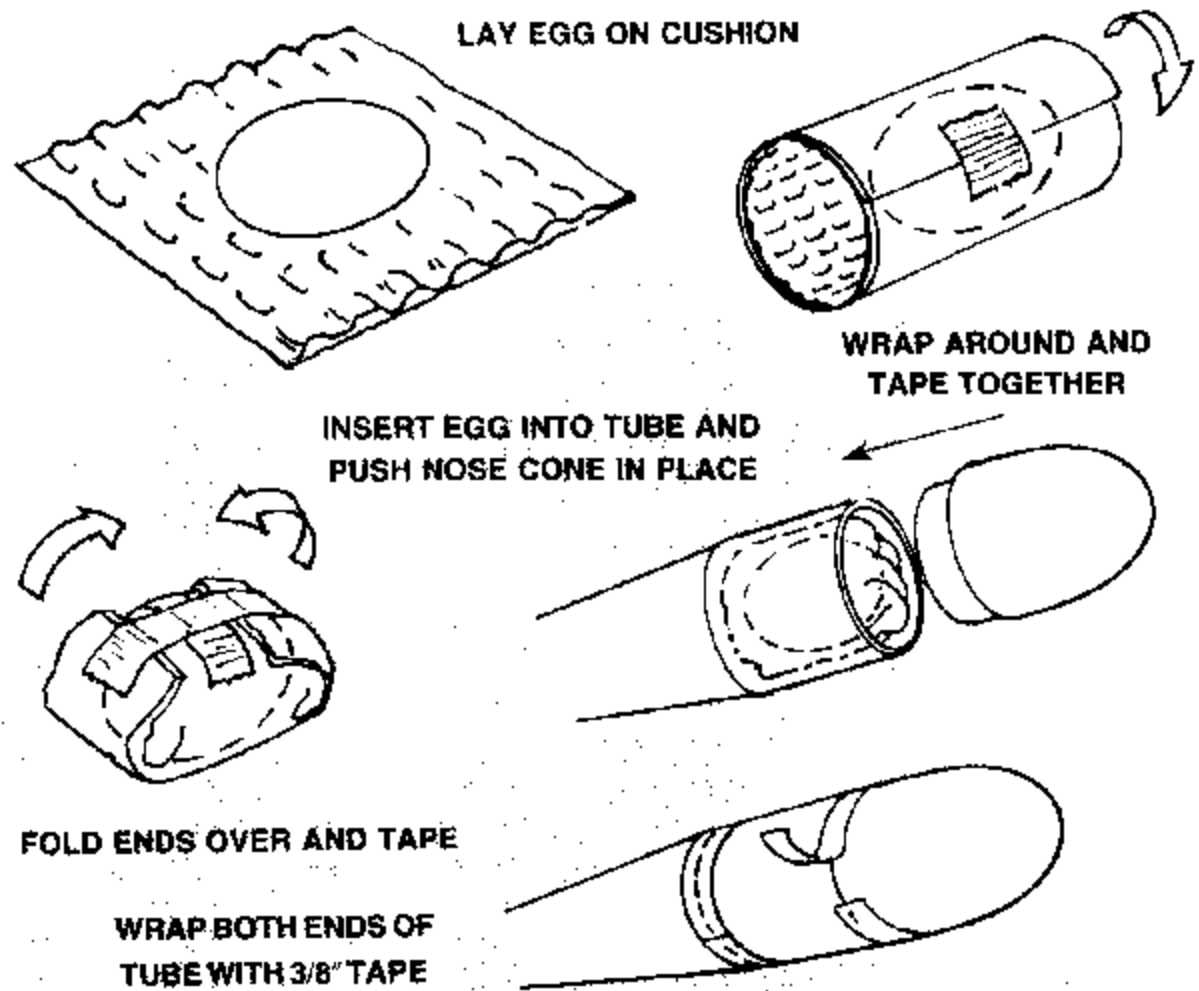

**IMPORTANT NOTE:** This model may be flown with or without an egg payload. In either case, the egg tube must be firmly taped to the nose and tail cone. Otherwise, these parts might separate when the parachute is deployed, and they could be lost. Careful attention must also be paid to engine selection. Page 6 lists a range of engines that may be used to power this rocket when it is flown without an egg payload. When launching with an egg, use only an Estes C5-3 engine.

## ROCKET PREFLIGHT

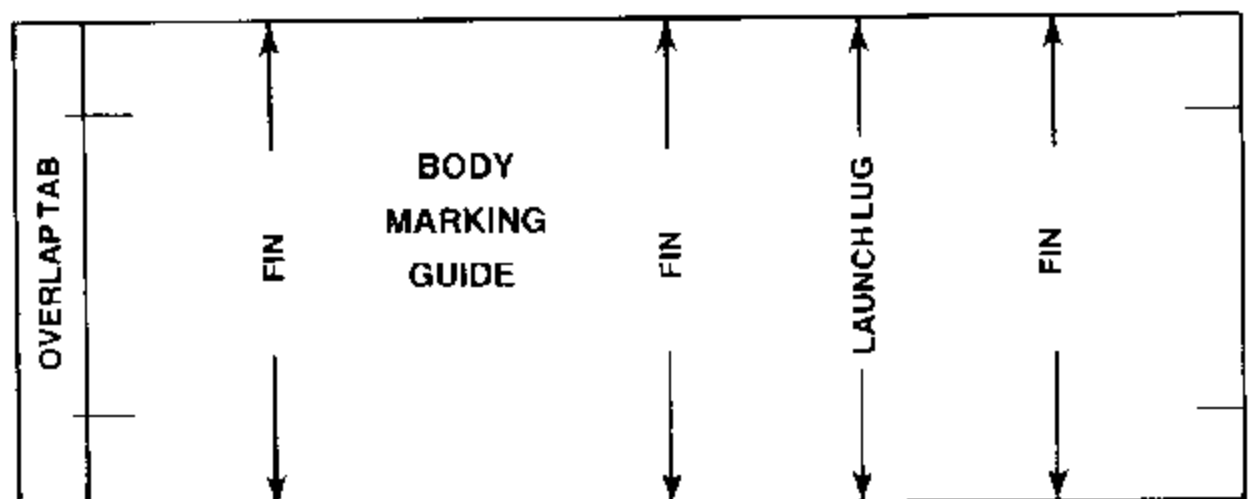
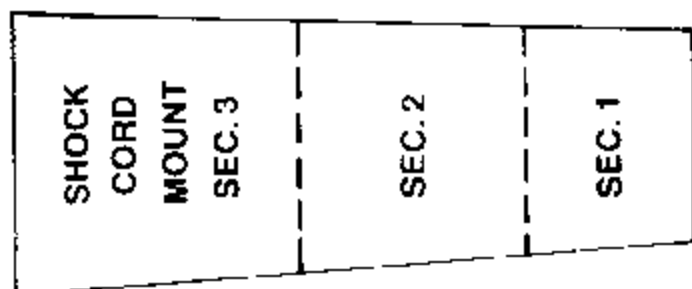
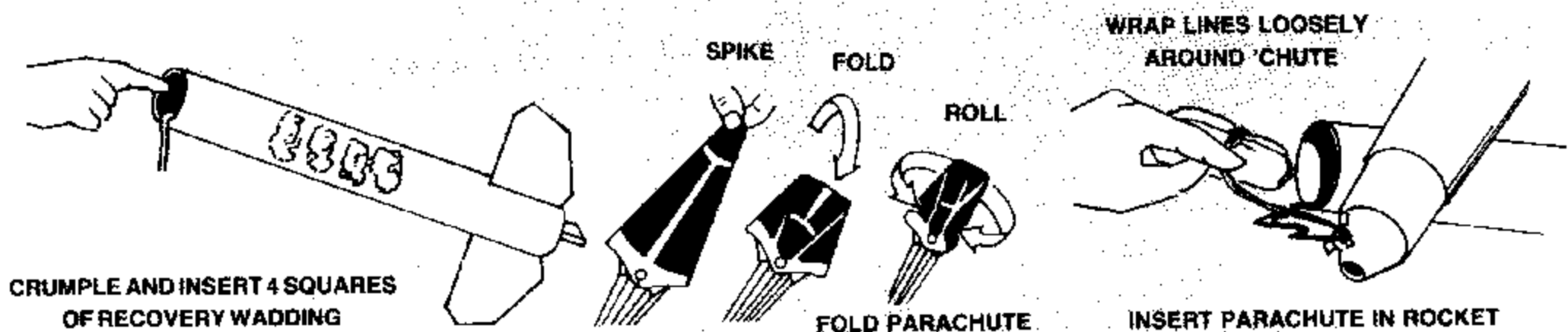

IGNITER PLUGS COME WITH ENGINES AND ARE NOT INCLUDED IN THIS KIT



If your engines do not come with igniter plugs, follow the instructions that come with the engines for securing igniters.

SEPARATE IGNITER AND IGNITER PLUG

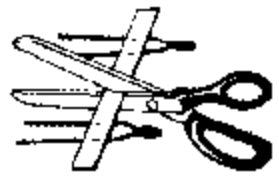

HOLD ENGINE UPRIGHT, DROP IN IGNITER



IGNITER MUST TOUCH PROPELLANT

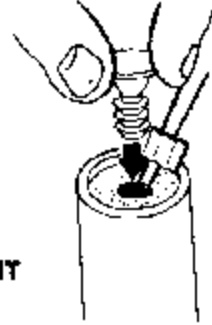

INSERT IGNITER PLUG

BEND IGNITER WIRES BACK

FIRMLY PUSH ALL THE WAY IN

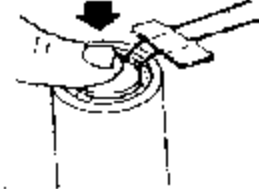

INSTALL ENGINE IN ROCKET

HOOK MUST LATCH OVER ENGINE

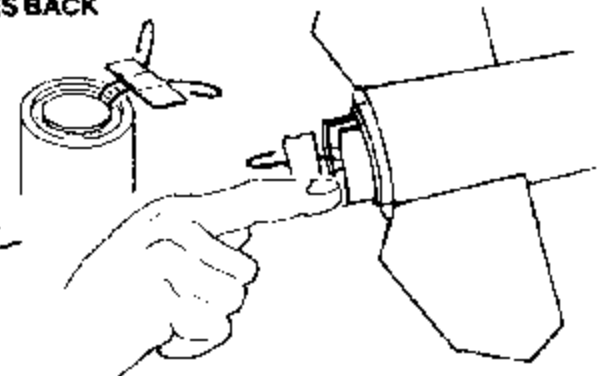

## COUNTDOWN AND LAUNCH

## LAUNCH SUPPLIES

To launch your rocket you will need the following items:

- An Estes model rocket launching system
  - Estes Recovery Wadding (No. 2274)
  - Recommended Engines: WITHOUT EGG: B4-2, B6-2, B8-5, C6-5.  
Use a B4-2 for first flight to become familiar with rocket's flight pattern.
  - For launching WITH egg: USE AN ESTES C5-3 ENGINE ONLY.
  - DO NOT LAUNCH AN EGG WITH ANY ENGINE EXCEPT C5-3.
- Use only Estes products to launch this rocket.

## FLYING YOUR ROCKET

Choose a large field away from power lines, tall trees, and low flying aircraft. Try to find a field at least 250 feet square. The larger the launch area, the better your chance of recovering your rocket. Football fields and playgrounds are great.

Launch area must be free of dry weeds and brown grass.

Launch only during calm weather with little or no wind and good visibility.

Don't leave parachute packed more than a minute or so before launch during cold weather [colder than 40° Fahrenheit (4° Celsius)]. Parachute may be dusted with talcum powder to avoid sticking.

## MISFIRES

Failure of the rocket engine to function properly is nearly always caused by a failure to install the igniter correctly. This failure permits the igniter to heat and burn into two pieces without igniting the engine.

## FOR YOUR SAFETY AND ENJOYMENT

Always follow the NAR-HIA\* MODEL ROCKETRY SAFETY CODE while participating in any model rocketry activities.

\*National Association of Rocketry-The Hobby Industry of America

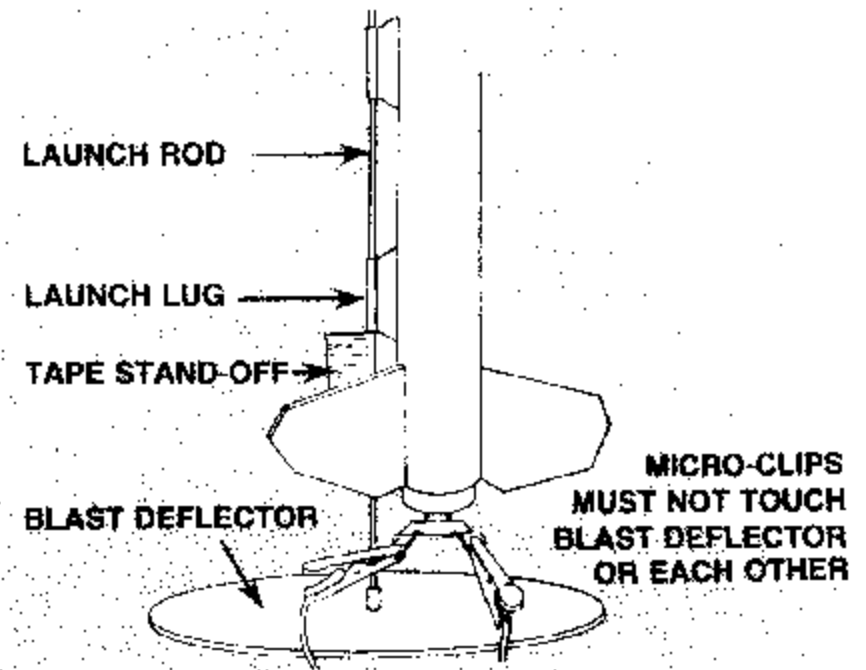

- ⑩ REMOVE SAFETY KEY to disarm the launch controller.
- ⑨ Remove safety cap and slide launch lug over launch rod to place rocket on launch pad. Make sure the rocket slides freely on the launch rod. You will need to use a rocket stand-off that comes with your launcher to launch this rocket. If you do not have one, you can make a stand-off by wrapping masking tape around the rod as shown.
- ⑧ Attach micro-clips to the igniter wires. Arrange the clips so they do not touch each other or the metal blast deflector. Attach clips as close to protective tape on igniter as possible.
- ⑦ Move back from your rocket as far as launch wire will permit (at least 15 feet).
- ⑥ INSERT SAFETY KEY to arm the launch controller. Give audible countdown. . . 5 . . 4 . . 3 . . 2 . . 1 . .

**LAUNCH!!** PUSH AND HOLD LAUNCH BUTTON UNTIL ENGINE IGNITES  
Remove safety key—Replace cap on rod.