



ESTES INDUSTRIES
1295 H Street
Penrose, CO 81240

EX
SERIES

Almost Ready To Fly

(7-96) 82106

EST 2130

MACH 12™ FLYING MODEL ROCKET KIT INSTRUCTIONS

TOOLS REQUIRED:

SCISSORS, PENCIL, HOBBY KNIFE, WHITE GLUE, TUBE-TYPE PLASTIC CEMENT AND SANDPAPER

ALL GLUED AREAS ARE SHADED IN GRAY

PARTS LAYOUT

NOT USED
ORANGE LAUNCH LUGS (2) 33550

LONG BODY TUBE #56 (1)
7" (17.8 cm)
30342

BLACK NOSE CONE
56A 72015

SHORT BODY TUBE #56 (1)
30343

PLASTIC TUBE COUPLER WITH LAUNCH LUG (1)
33550

SHOCK CORD
1/4 X 24 (1)
38383

PLASTIC ENGINE MOUNT HALVES (2)
33550

TAPE RINGS (1)
38407

PLASTIC ENGINE LOCK RING (1)
33550

SHROUD LINES #108 (1)
38239

DECALS (1)
37718

PARACHUTE #18 (1)
35821

PLASTIC FINS (3 SETS) 33550

1.

A. Cement the two plastic engine mount halves together. Remove any excess cement from fin slots.

3.

A. Apply a ring of plastic cement inside the short body tube, and slide the tube onto the shoulder of the engine mount.

C. Apply a ring of plastic cement inside the engine mount. Slide cross body tube. Align...

E. Apply... NOT G... into t...

5.

A. Clean flash from eyelet and nose cone.

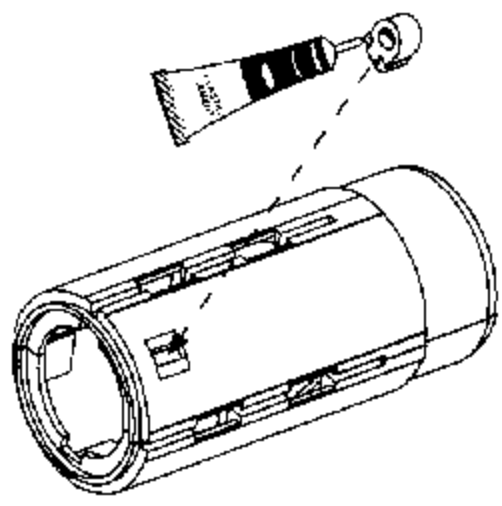

B. Cement a launch lug into the recessed area on engine mount as shown.

2.

NOTE: The Mach-12 has three sets of four non-reversible fins that can be interchanged to make twelve different styles of rocket. **DO NOT CEMENT FINS INTO ENGINE MOUNT ASSEMBLY**

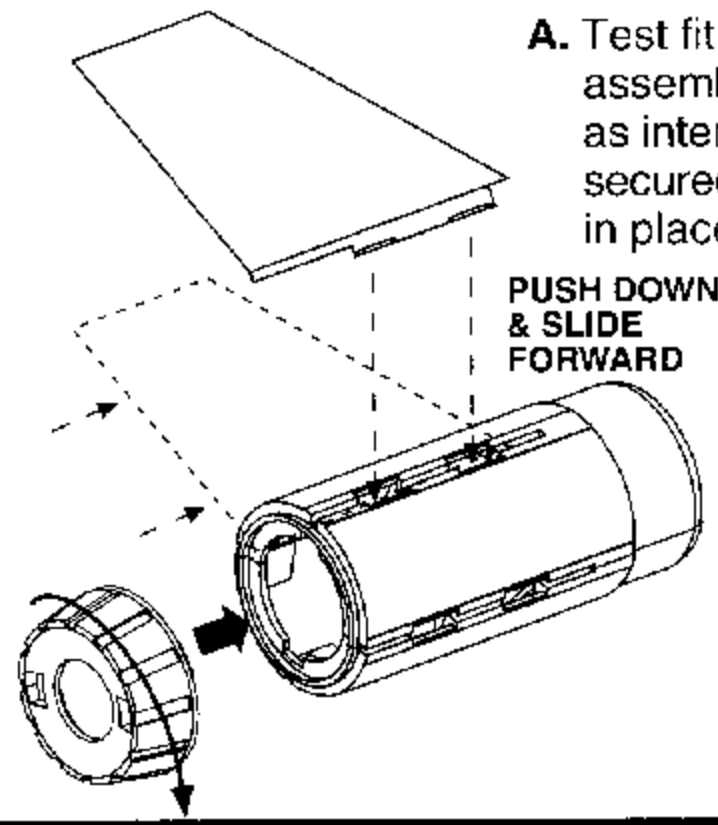

A. Test fit each fin into slots on engine mount assembly to make sure fins insert and function as intended. Fins should slide into slots and be secured in place by twisting the engine lock ring in place.

B. Clean any plastic flash from fins or slots as necessary with fine grit sandpaper to ensure proper fit.

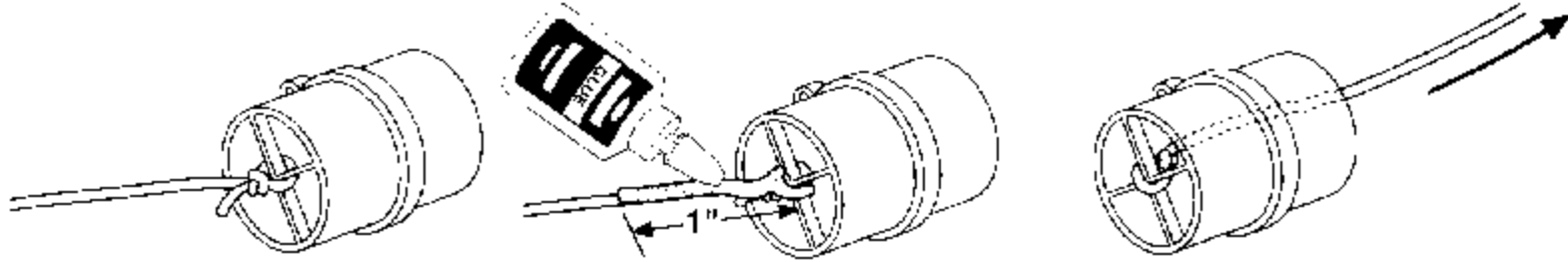

B. Tie one end of shock cord to the cross bars of the tube coupler with a double knot. Apply white glue to knot and 2.5 CM (1") of cord. Feed cord through coupler.



ALIGN LAUNCH LUGS (SEE DRAWING AT RIGHT)

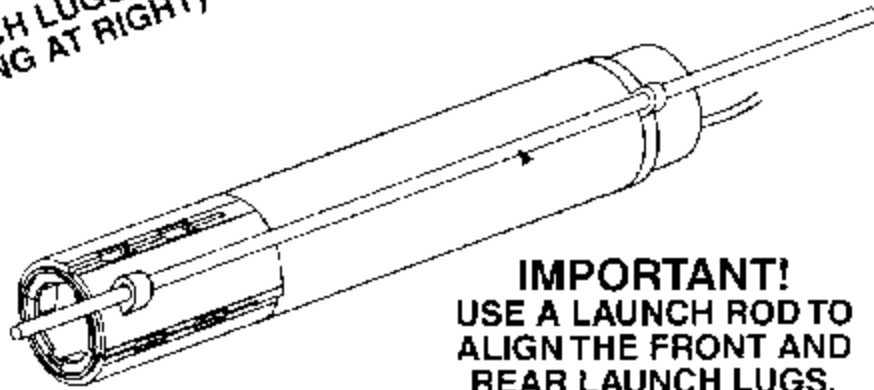

IMPORTANT!
USE A LAUNCH ROD TO ALIGN THE FRONT AND REAR LAUNCH LUGS.

ring of plastic cement just the end of the short body tube. cross bar end of coupler into align launch lugs as shown.

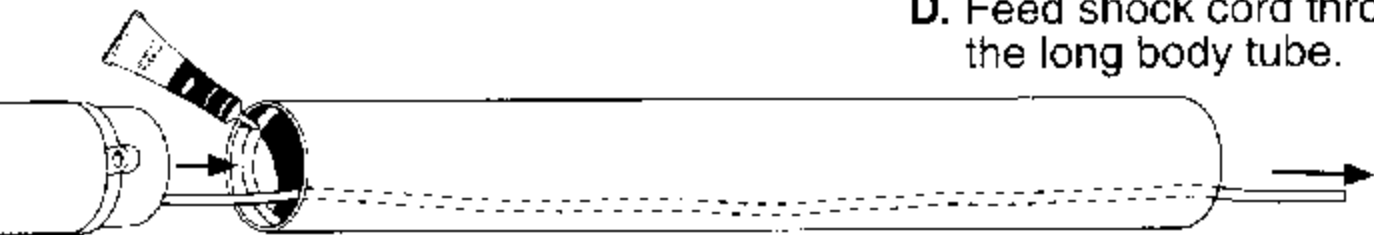

D. Feed shock cord through the long body tube.

Apply a ring of cement just inside one end of the longer tube. **BE CAREFUL TO NOT GET CEMENT ON SHOCK CORD.** Slide the tube coupler/lower body tube assembly into the long body tube. Allow assembly to dry.

4.

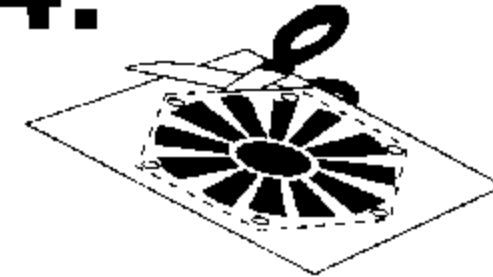

A. Cut out parachute on dotted line.

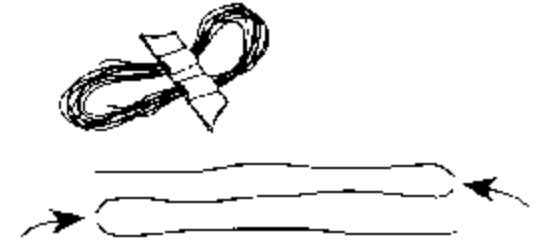

B. Find shroud line material. Remove tape. Using all of the shroud line, fold and cut into three equal lengths.

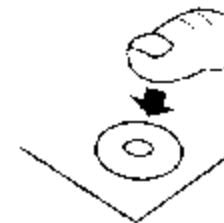

C. Press tape rings onto marks on corners.

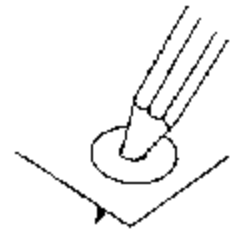

D. Punch holes with sharp pencil.

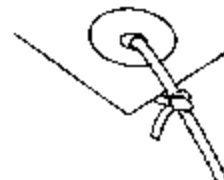

E. Tie lines off with a double knot.

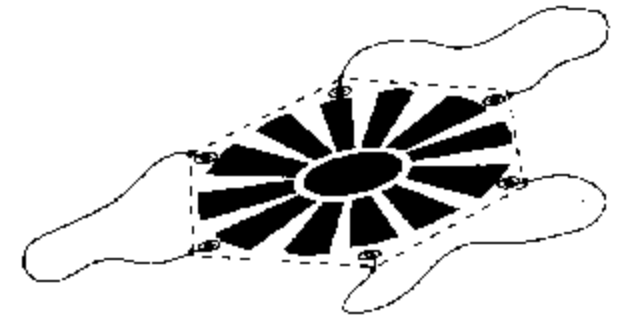

COMPLETED PARACHUTE

6.

A. Form loop with shroud lines.

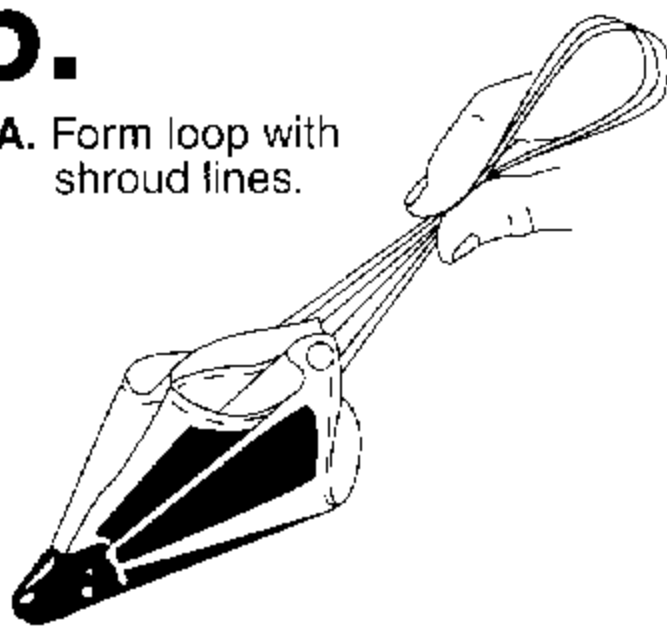

B. Push loop through eyelet of nose cone.

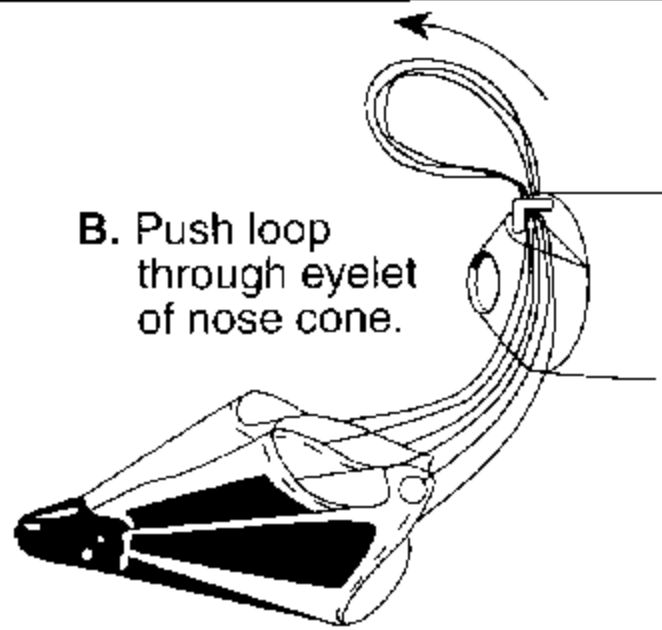

C. Pass parachute through loop.

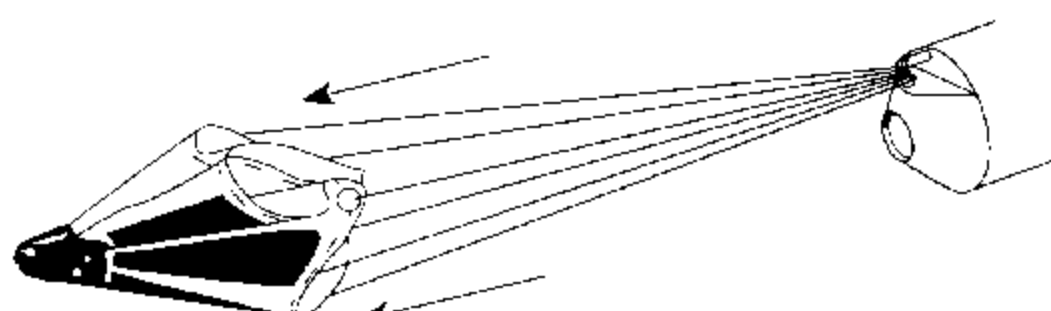
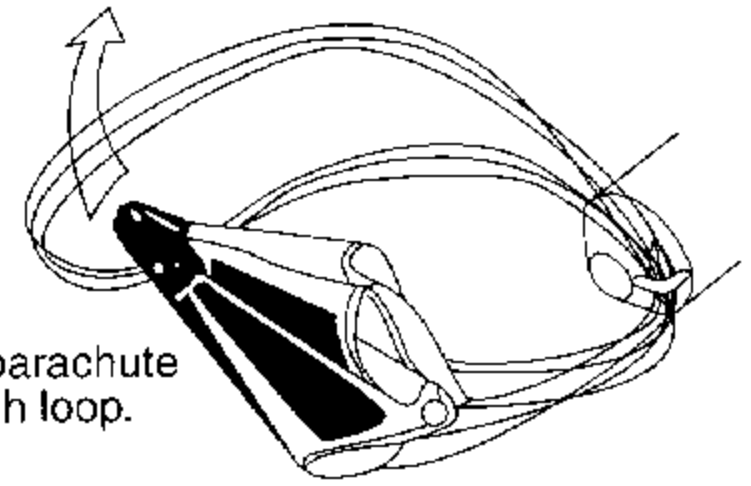

D. Pull tight.

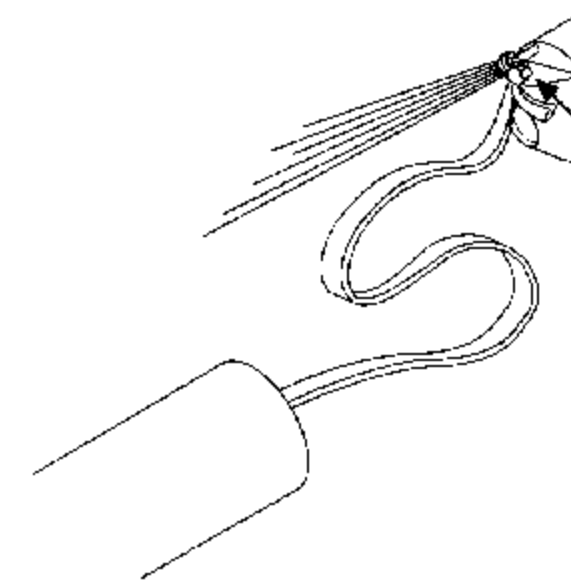

E. Tie shock cord to the eye of the nose cone with a double knot.

7. PACKING PARACHUTE

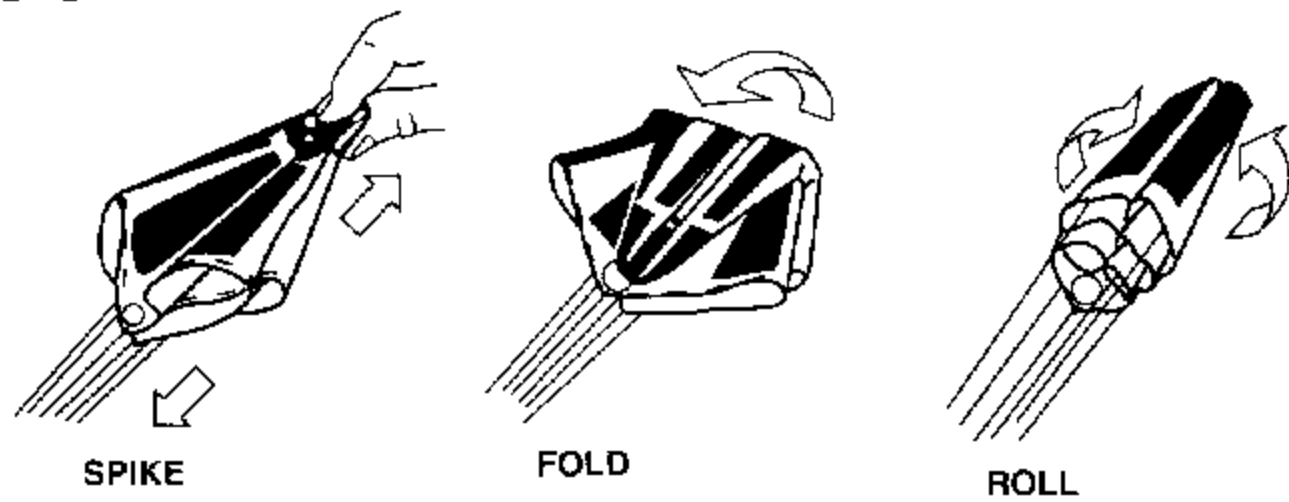

DO NOT FORGET TO PACK RECOVERY WADDING IN THE ROCKET BEFORE FLYING - SEE STEP 9

WRAP LINES LOOSELY AROUND 'CHUTE,
INSERT 'CHUTE INTO ROCKET

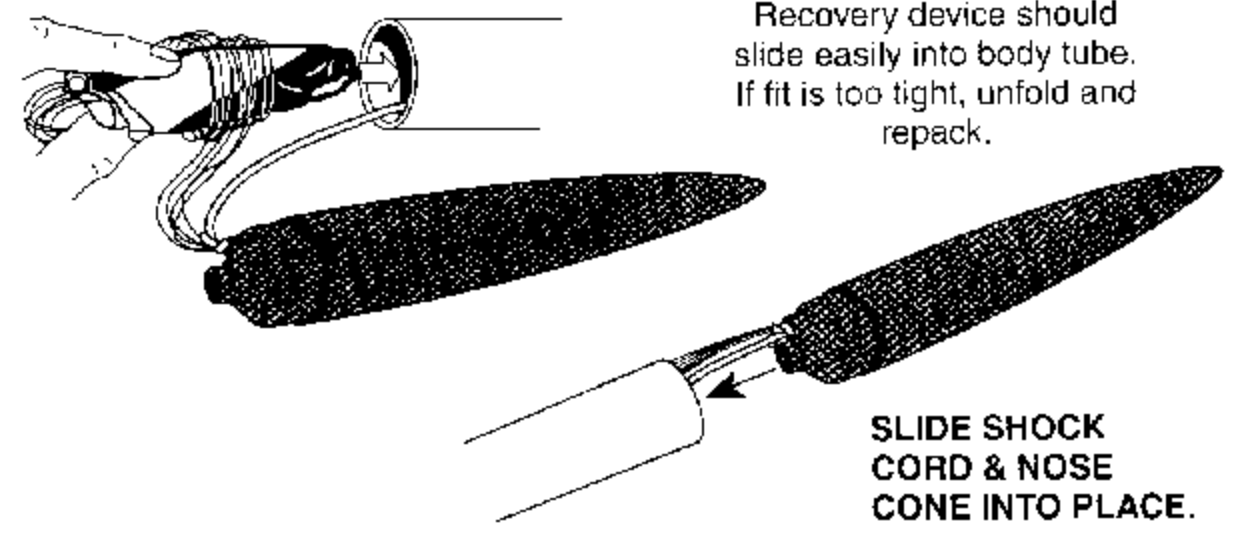

Recovery device should slide easily into body tube. If fit is too tight, unfold and repack.

SLIDE SHOCK CORD & NOSE CONE INTO PLACE.

8. APPLYING DECALS

REMOVE DECALS ONE AT A TIME FROM BACKING SHEET AND APPLY AS SHOWN ON BOX ART.

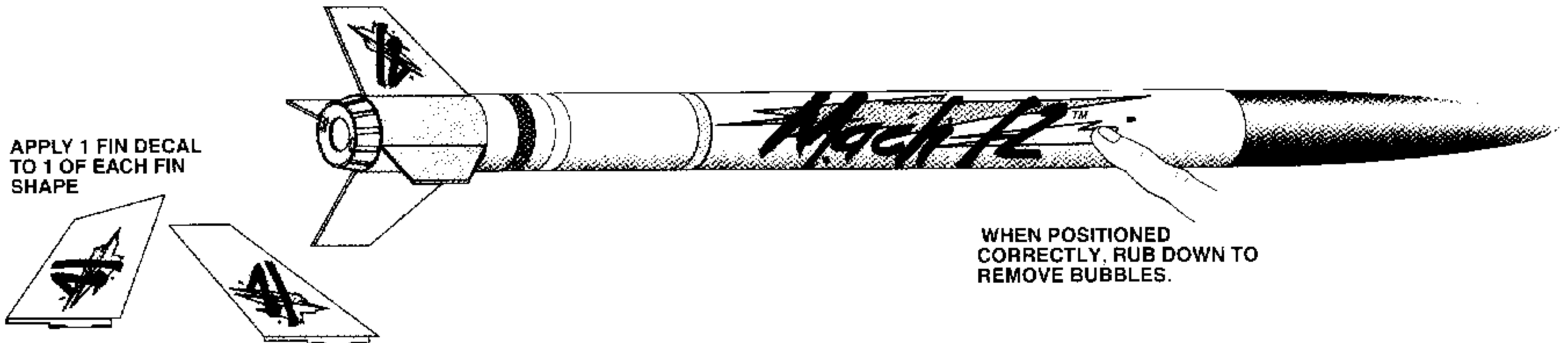

APPLY 1 FIN DECAL TO 1 OF EACH FIN SHAPE

WHEN POSITIONED CORRECTLY, RUB DOWN TO REMOVE BUBBLES.

9. FLYING YOUR ROCKET

ROCKET PREPARATION

Remove nose cone, shock cord and parachute.

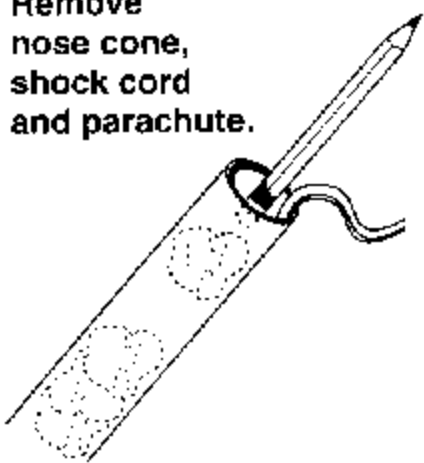

Crumple and insert four squares of recovery wadding. Repack and insert parachute, shock cord and nose cone.

ENGINE PREPARATION

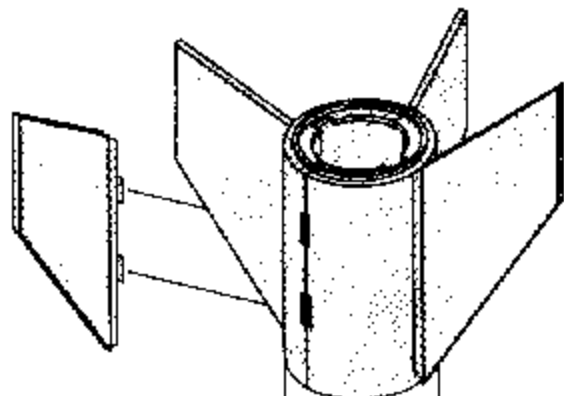

1. CHOOSE ANY 4 FINS & INSERT

YOU MUST NOT FLY YOUR MACH 12™ WITH LESS THAN 4 FINS.

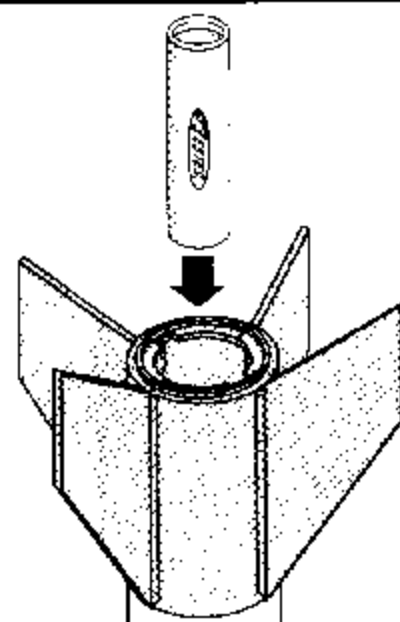

2. SLIDE ENGINE INTO ENGINE MOUNT

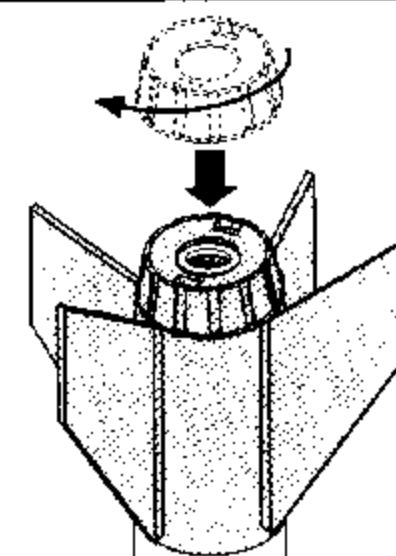

3. Twist on plastic engine lock ring to hold engine and fins in place. (To change fins, untwist and remove lock ring, exchange fins, replace lock ring.)

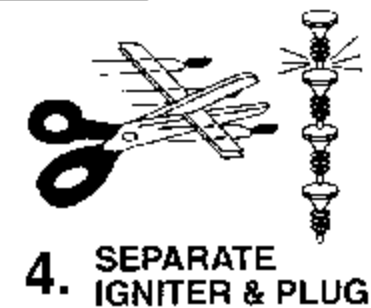

4. SEPARATE IGNITER & PLUG

5. HOLD ROCKET BOTTOM END UP, DROP IN IGNITER. IGNITER MUST TOUCH PROPELLANT.

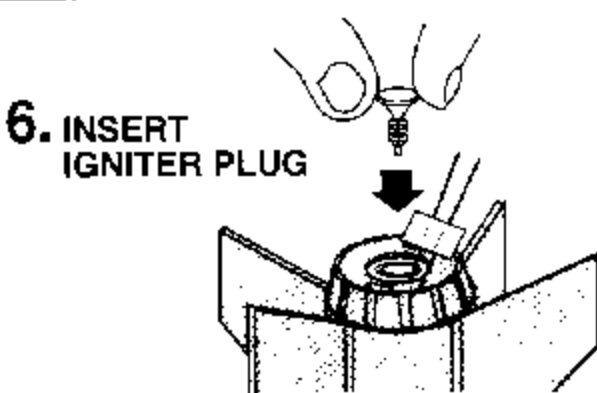

6. INSERT IGNITER PLUG

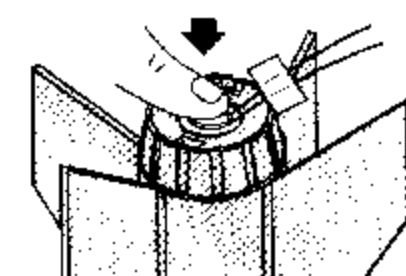

7. FIRMLY PUSH ALL THE WAY IN

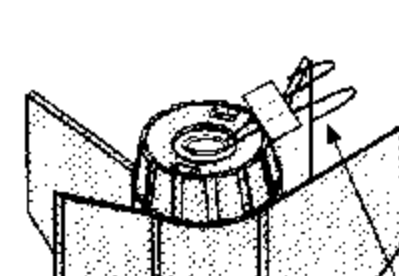

8. BEND IGNITER WIRES BACK

LAUNCH SUPPLIES

To launch your rocket, you will need the following:

- Launch Pad (Estes Porta-Pad® II)
- Launch Controller (Estes Electron Beam®)
- Recommended Estes Engines: A8-3, B4-4, B6-4, or a C6-5. Use an A8-3 for your first flight.
- Recovery Wadding (EST 302274)
- Igniters and Igniter Plugs (included with Estes engines.)

ENGINE	PROJECTED ALTITUDE	
	Feet	Meters
A8-3	128	39
B4-4	307	94
B6-4	326	99
C6-5	650	198

DO NOT LAUNCH YOUR MACH 12™ WITH LESS THAN 4 FINS OF ANY COMBINATION!

Use only Estes products to launch this rocket.

TIPS FOR FLYING YOUR ROCKET

- Choose a large field away from power lines, buildings, tall trees, and low flying aircraft. Try to find a field at least 76 meters (250 feet) square. The larger the launch area, the better your chance of recovering your rocket.
- Launch area must be free of dry weeds and brown grass.
- Launch only during calm weather with little or no wind and good visibility.
- Don't leave parachute packed more than a minute or so before launch during cold weather (colder than 4° Celsius [40° Fahrenheit]). Parachute may be dusted with talcum or baby powder to avoid sticking.
- Always follow the National Association of Rocketry (NAR) MODEL ROCKETRY SAFETY CODE while participating in any model rocketry activities. The safety code is enclosed with this kit.