

Estes Industries Rocket Plan No. 51

CHALLENGER

Designed By MARGIE PRATHER
Two-Stage Sport/Demonstration Bird

Published as a service to its customers by Estes Industries, Inc., Box 227, Penrose, Colorado

© Estes Industries 1967

Assembly

STEP 1. Glue a 2060 spacing ring to each end of two JT-60C couplers to start assembly of the engine mounts. Glue the EB-20A into one end of the BT-20J tube. Mark this tube $\frac{3}{32}$ " from the end which has the engine block. Mark the BT-20M tube $\frac{1}{4}$ " from one end. Let the ring-coupler assemblies dry before installing the engine tubes. When ready, install the tubes to the marks as shown.

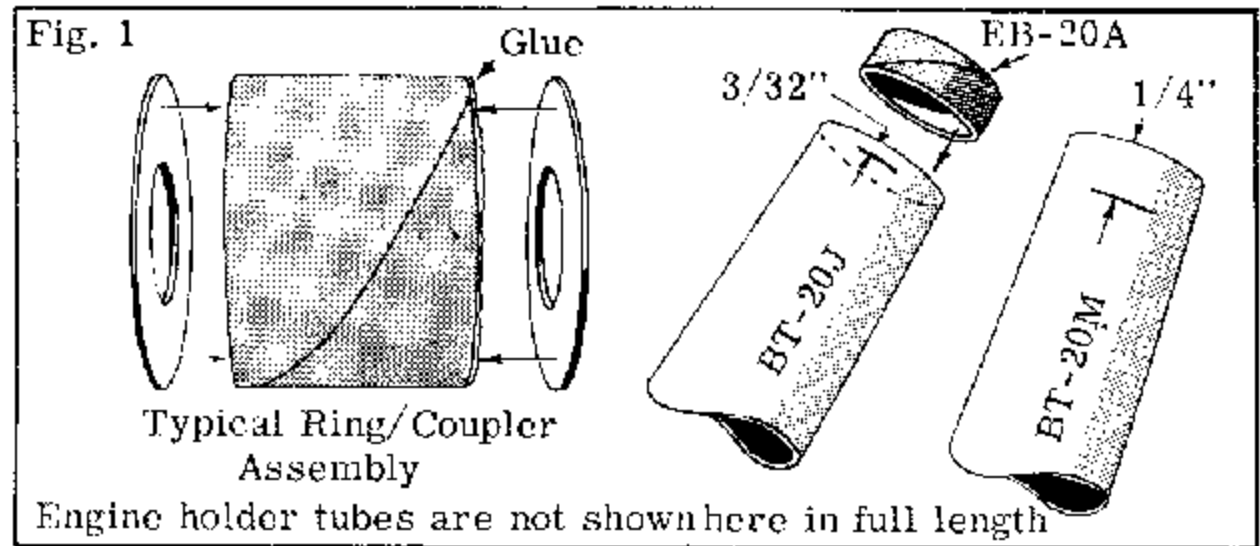

STEP 2. Trace the fin patterns onto heavy paper or card stock and carefully cut them out. Lay out three of each fin on the fin-stock. Cut out all fins and sand them smooth on the sides. All leading, tip and trailing edges are to be sanded round. Sand the root edges of all fins flat.

CUT-AWAY OF BODY TUBES AND RING/COUPLER ASSEMBLIES -- SHOWS RELATIVE POSITION OF ENGINE TUBES AND TRANSTAGE COUPLER.

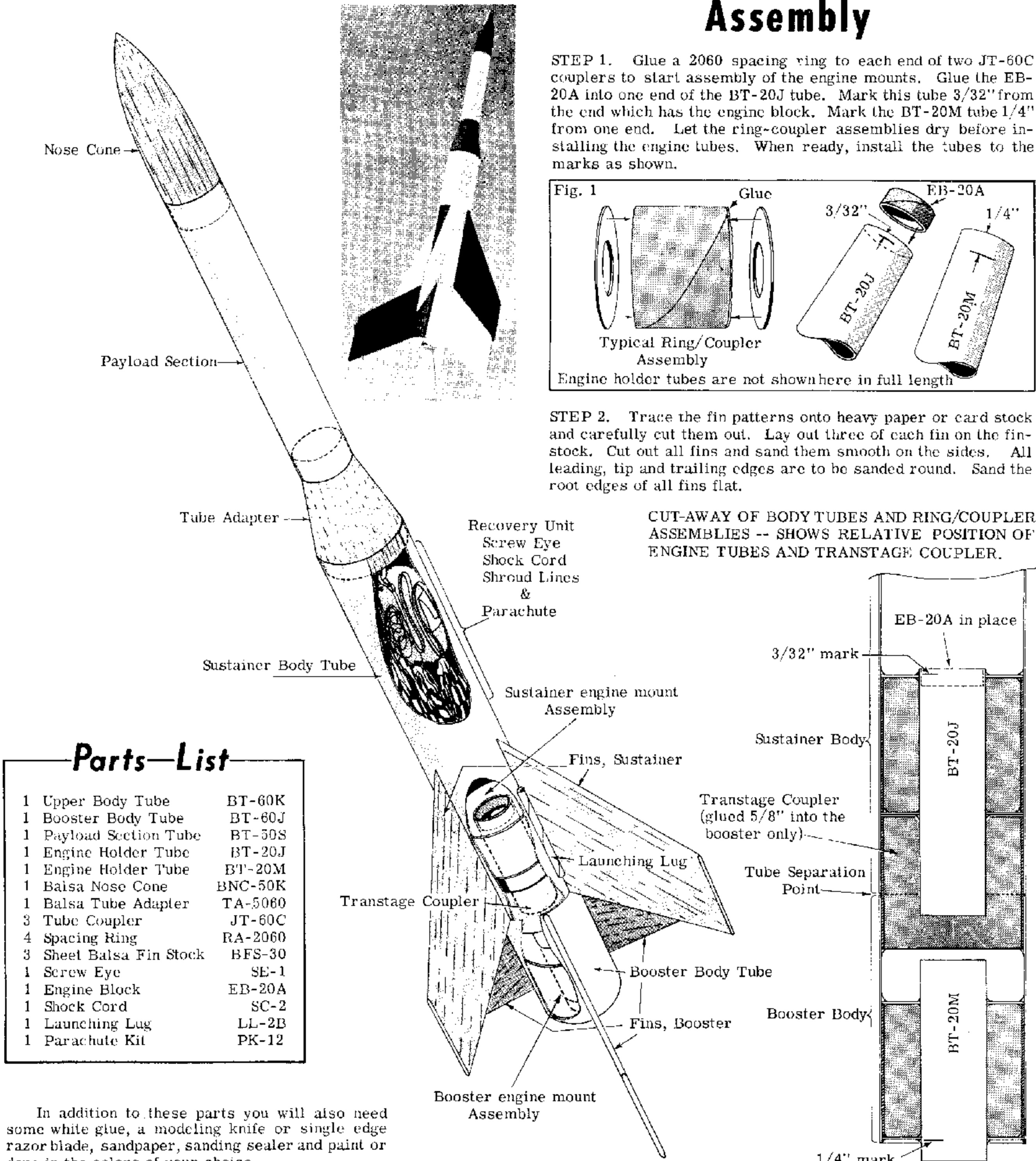

Parts List

1 Upper Body Tube	BT-60K
1 Booster Body Tube	BT-60J
1 Payload Section Tube	BT-50S
1 Engine Holder Tube	BT-20J
1 Engine Holder Tube	BT-20M
1 Balsa Nose Cone	BNC-50K
1 Balsa Tube Adapter	TA-5060
3 Tube Coupler	JT-60C
4 Spacing Ring	RA-2060
3 Sheet Balsa Fin Stock	BFS-30
1 Screw Eye	SE-1
1 Engine Block	EB-20A
1 Shock Cord	SC-2
1 Launching Lug	LL-2B
1 Parachute Kit	PK-12

In addition to these parts you will also need some white glue, a modeling knife or single edge razor blade, sandpaper, sanding sealer and paint or dope in the colors of your choice.

STEP 3. Carefully join one end of the BT-60K to the BT-60J tube with a couple of short strips of masking tape. Mark the BT-60J for three fins. Draw a guide line across the length of the BT-60J tube and extend the line at least four inches onto the longer tube from each of the fin location marks. Separate the tubes and glue the fins into place on each of the tubes. After the glue has dried, support the tubes horizontally and apply a glue fillet to each side of the fin root-body tube joint.

STEP 4. Apply a film of glue inside one end of the BT-50S and slide this end over the smaller end of the TA-50C0. Put a line of glue around the joint and spread it smooth with a finger. Slip the BNC-50K into place on the other end of the BT-50S. Install the SE-1 as shown and lay the assembly aside to dry.

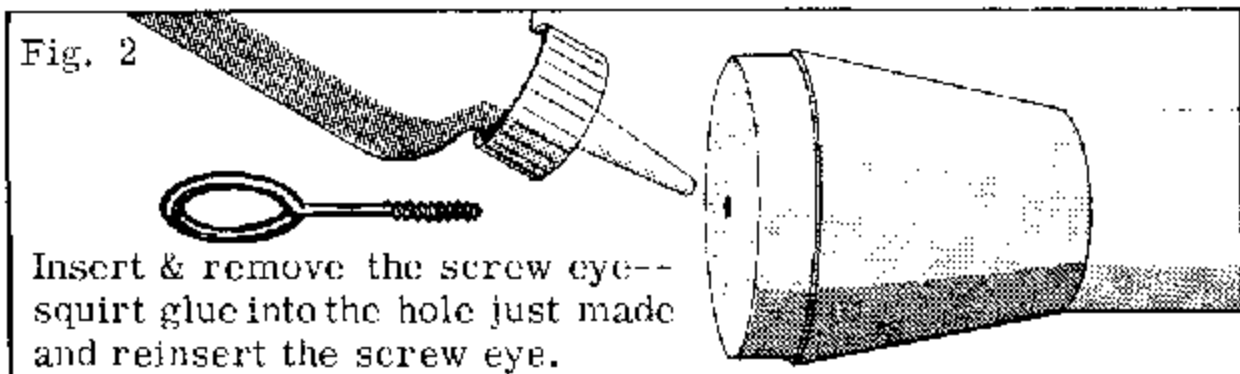

STEP 5. Assemble the parachute according to the instructions in the kit. Prepare a shock cord anchor as shown and install the unit inside the main body tube 1/2" from the forward end.

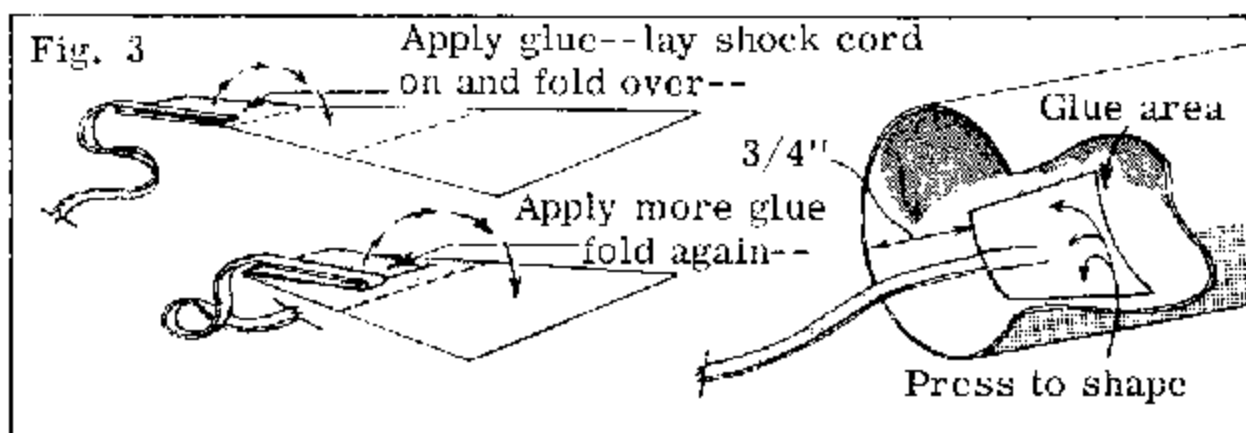

STEP 6. Apply a film of glue to the inside of the BT-60K main body tube over an area extending from 3/4" to 2-1/4" from the rear of the tube. Slide the engine holder unit with the longer tube into place, engine block end first, so the rear of the engine tube extends 1/4" beyond the rear of the main body tube. Install the other engine holder into the booster tube. Spread a film of glue for a depth of 1-1/4" inside the booster body from the rear. Pick up the engine holder unit by the end that has the 1/4" of the engine tube showing and slide the unit into the booster body from the rear. The ring-coupler is properly located when just 1/16" of the inside of the booster is showing. Apply a fillet of glue to this ring-tube joint and set the whole assembly aside to dry.

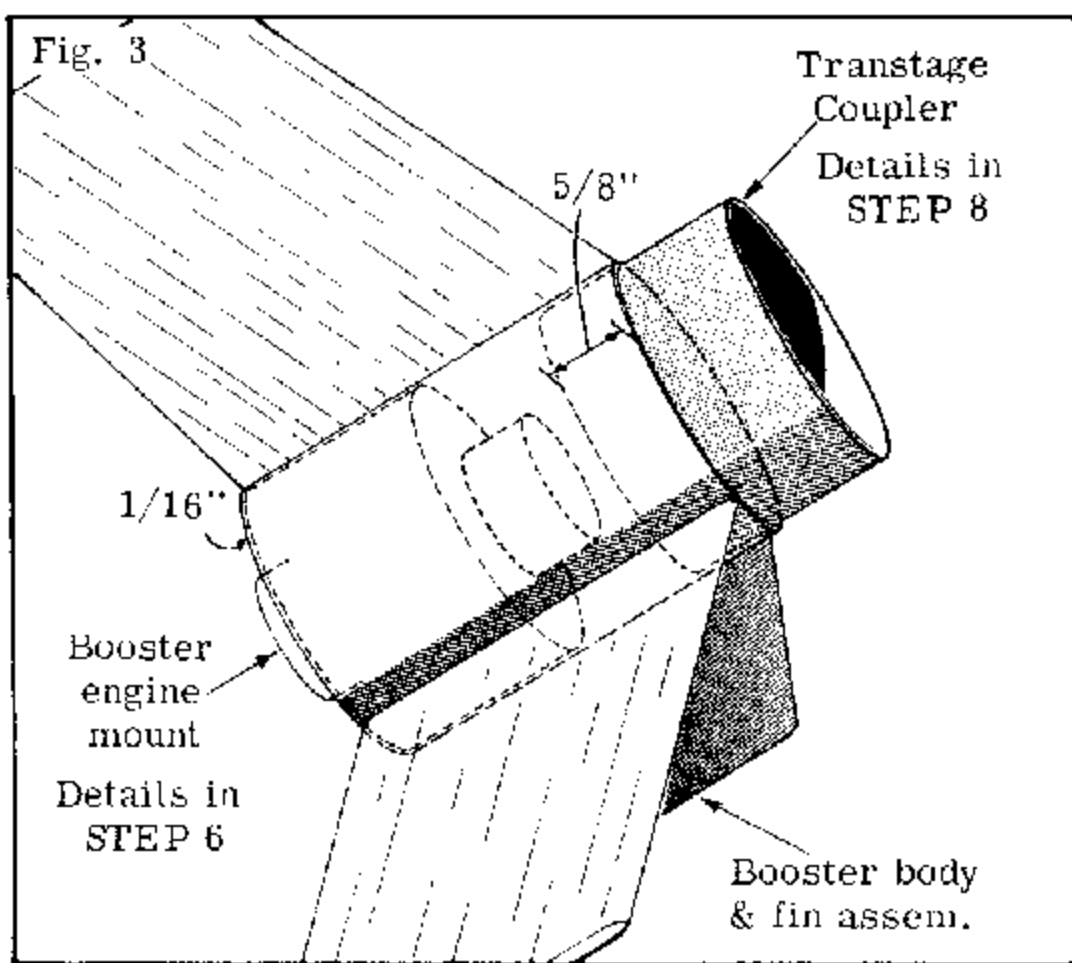

Trace the patterns onto cereal-box board to make a template of each.

STEP 7. Tie the shroud lines and free end of the shock cord to the screw eye of the payload section. Pack the 'chute into place and slip the payload section into place. Sand both coupler and nose cone smooth, particularly the tube-coupler and tube-nose cone joints, until there is a smooth transition from one to the other. Your upper stage is ready to finish in the colors of your choice.



STEP 8. Mark the remaining JT-60C at 5/8" from one end. Apply a film of glue to the inside of the front end of the booster assembly and slip the JT-60C into place 5/8" into the booster. Align this piece carefully to assure a true coupling to the upper stage. The booster is now ready to finish to compliment the upper stage.

GENERAL ENGINE RECOMMENDATIONS

Including the booster, this bird weighs 2.18 ounces allowing up to 3-ounce payloads using Series II engines. For sports and demonstration flying (no payload) the Challenger has performed properly with as little as a 1/4A.8-0, 1/4A.8-4 Series I engine pair. Use B engine pairs for flying the average (1-2 ounce) research payload.

Fin Patterns

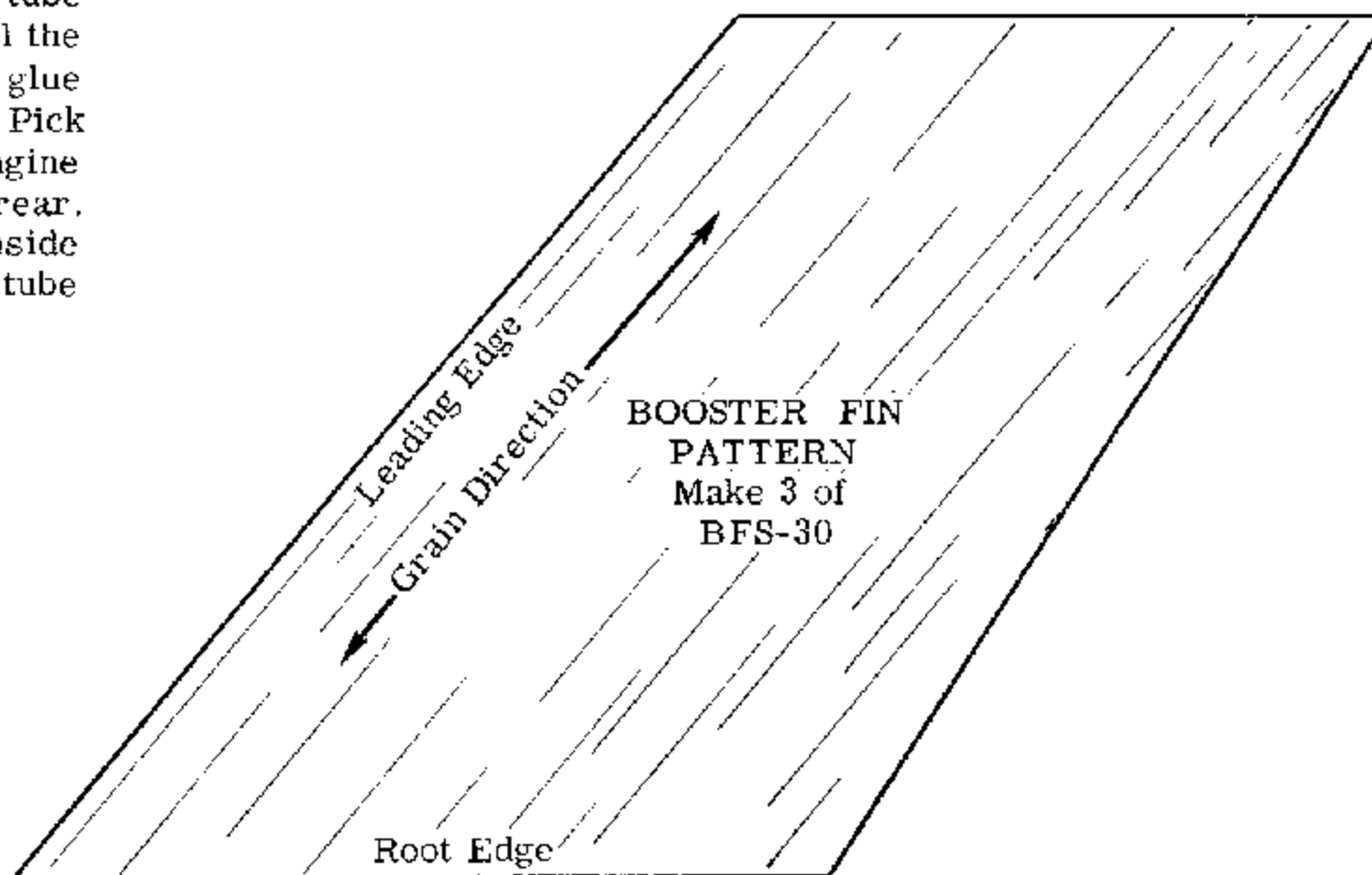

See STEP 2 for fin preparation.

