

EFFORT III
FIRST PLACE LEADER DIVISION
IN DESIGN EFFICIENCY AT
NARAM 12 -- HOUSTON, TEXAS

DESIGNED BY
RICHARD J. RYNEARSON
N.A.R. NO. 16924
COLLEGE STATION, TEXAS
 ESTES INDUSTRIES ROCKET PLAN NO. 75

PARTS LIST

(Refer to Fig. 8)

- 1 Nose Cone – BNC-20B
- 1 Body Tube – BT-20D
- 1 Engine Block – EB-20B
- 1 Fin Material – BFS-20
- 1 Launch Lug – LL-2A
- Monofilament Fishing Line (15 in. req., 15 lb. test)
- Rayon Elastic Shock Cord (5 in. req., 1/8 in. wide)
- 1 Small Safety Pin

ADDITIONAL MATERIALS

- Hobby Knife
- White Glue
- Ruler
- 320 Grit Mylar Sanding Material
- Sanding Sealer
- Color Enamel (Spray)
- Paint Brush
- Rubbing Compound
- Sharp Pencil

RECOMMENDED ENGINES
 1/4A3-4S 1/2A6-4S

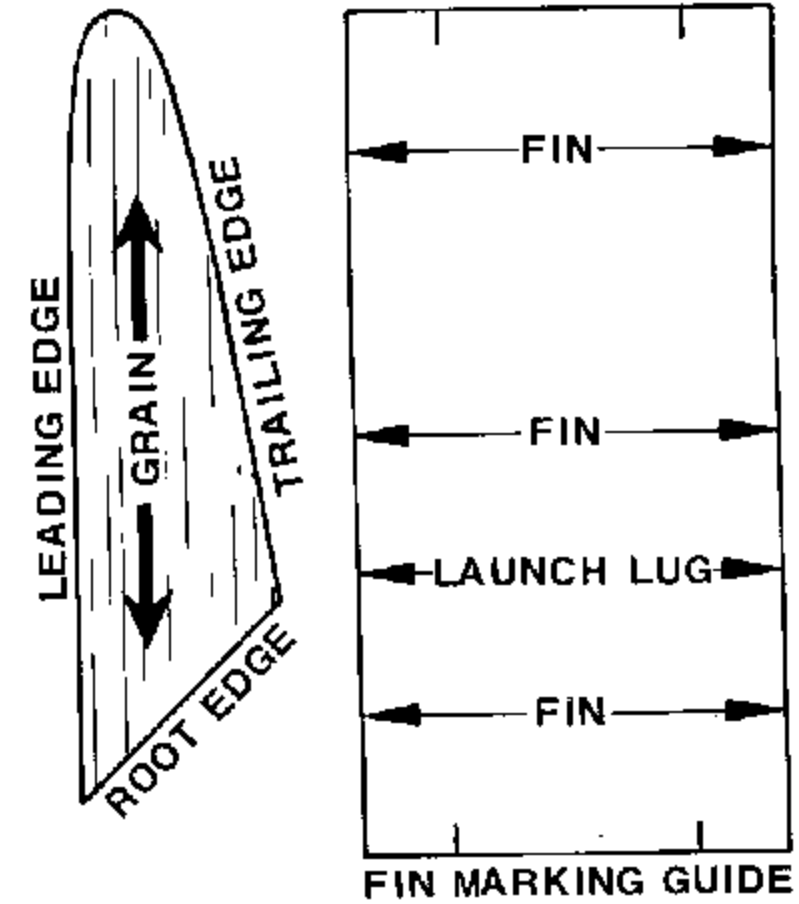

ASSEMBLY INSTRUCTIONS

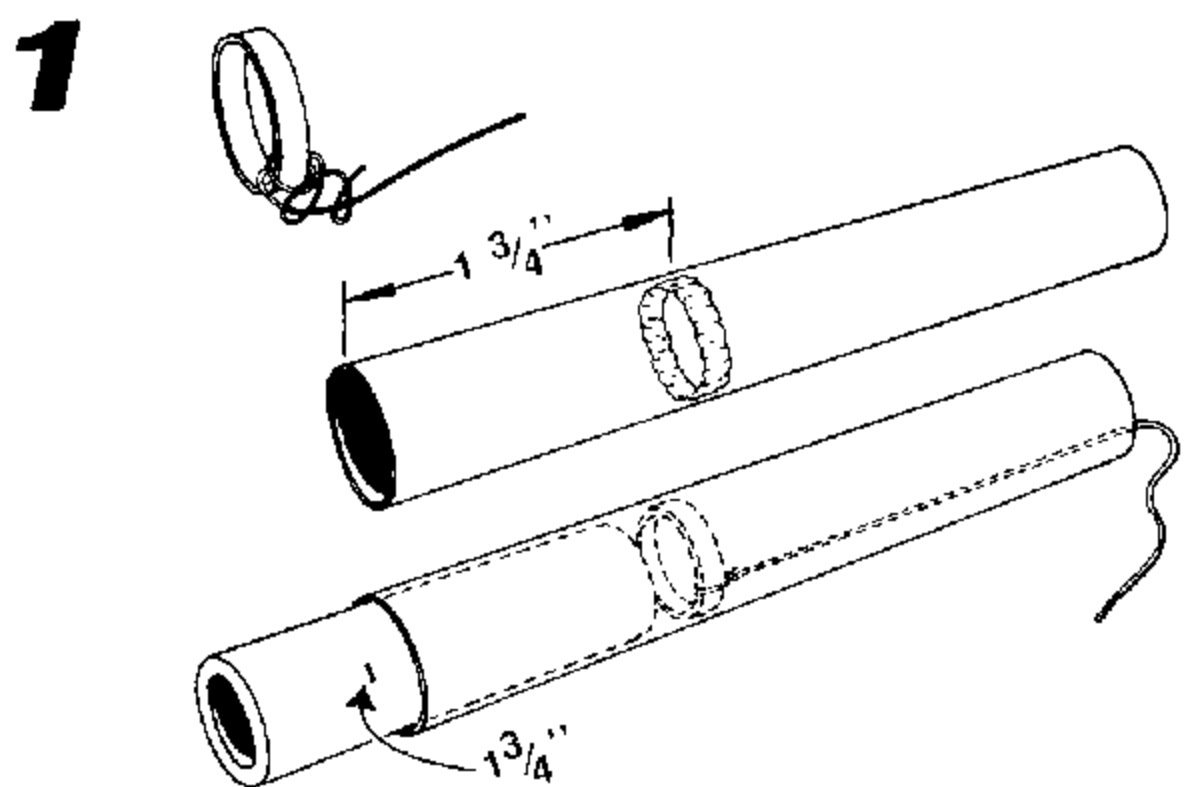

1 Cut a body tube that is 4" long. Take a 15" length of fishing line and tie one end securely to the engine block. Spread a thin ring of glue around the inside of the body tube 1-3/4" from one end. Insert the engine block inside the tube, feeding the fishing line in ahead of it. Using a regular engine casing marked at 1-3/4", slide in the engine block, stopping at the mark. Immediately remove the engine casing.



2 Split the nose cone in half with a modeling knife. Hollow out both halves until the wood thickness is 1/16". Glue the halves together and set aside to dry.

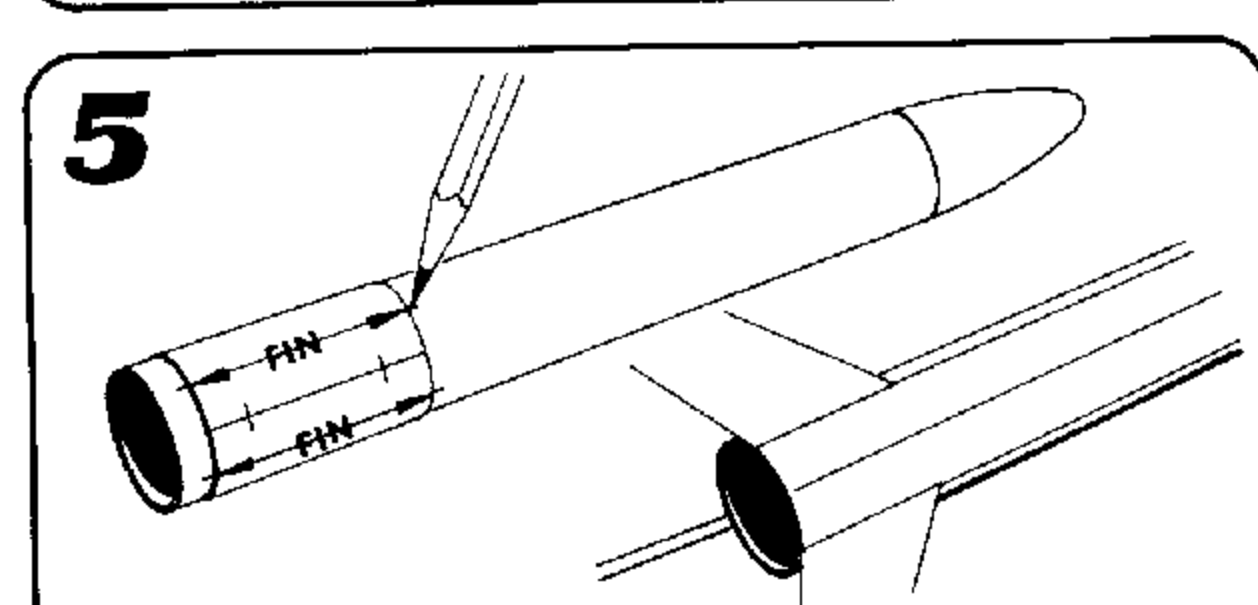
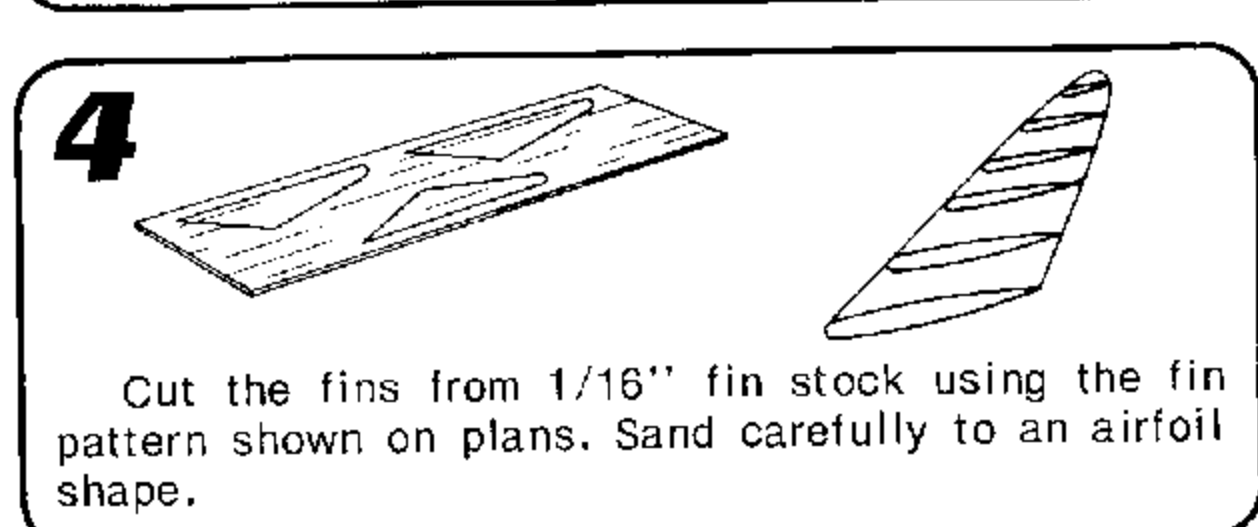
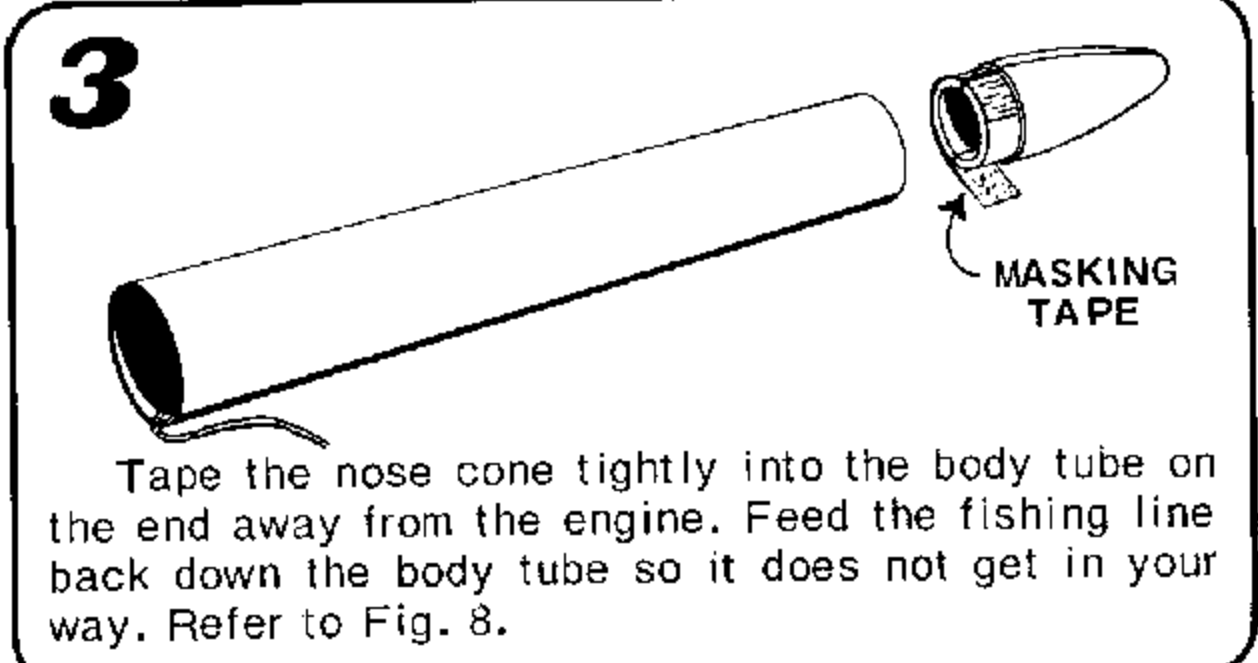

3 Tape the nose cone tightly into the body tube on the end away from the engine. Feed the fishing line back down the body tube so it does not get in your way. Refer to Fig. 8.

4 Cut the fins from 1/16" fin stock using the fin pattern shown on plans. Sand carefully to an airfoil shape.

5 Mark the body tube for three fins on the engine end. Also, draw a line along the tube centered between two of the fin markings for the launch lugs. Glue the fins to the body, making certain they point straight out from the body and are aligned along the tube.

6

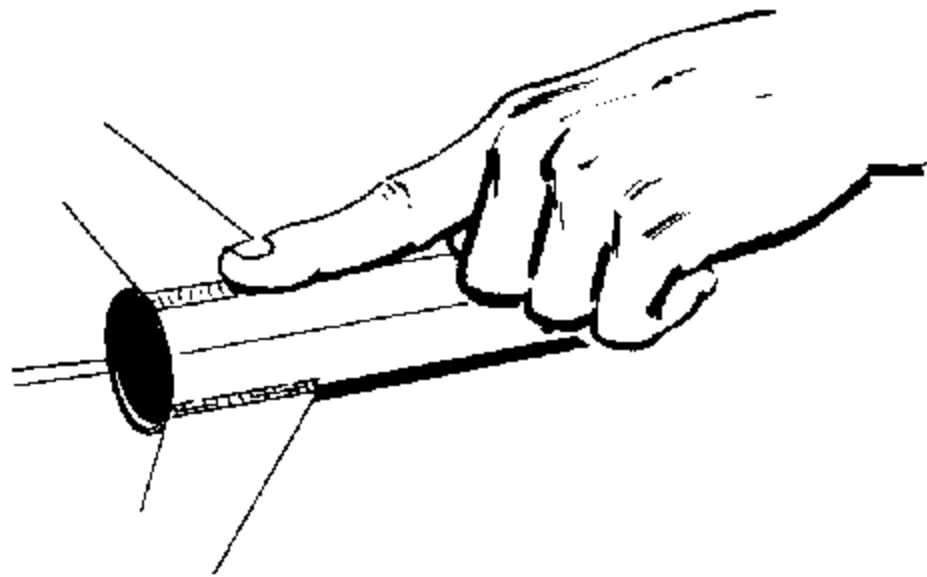

When the fins have dried, run a small glue fillet along the base of each fin.

7

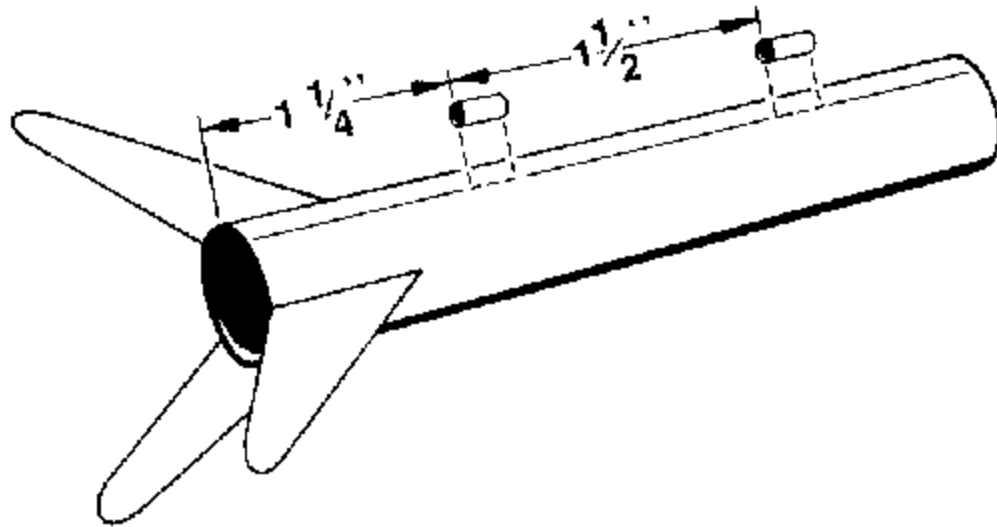

Using a pencil, mark the body tube along the launch lug line 1-1/4" and 2-3/4" from the end of the tube. Glue a 1/4" long launch lug to each position. Be careful to align each lug so the model will slide smoothly on the launch rod.

8 RECOVERY SYSTEM

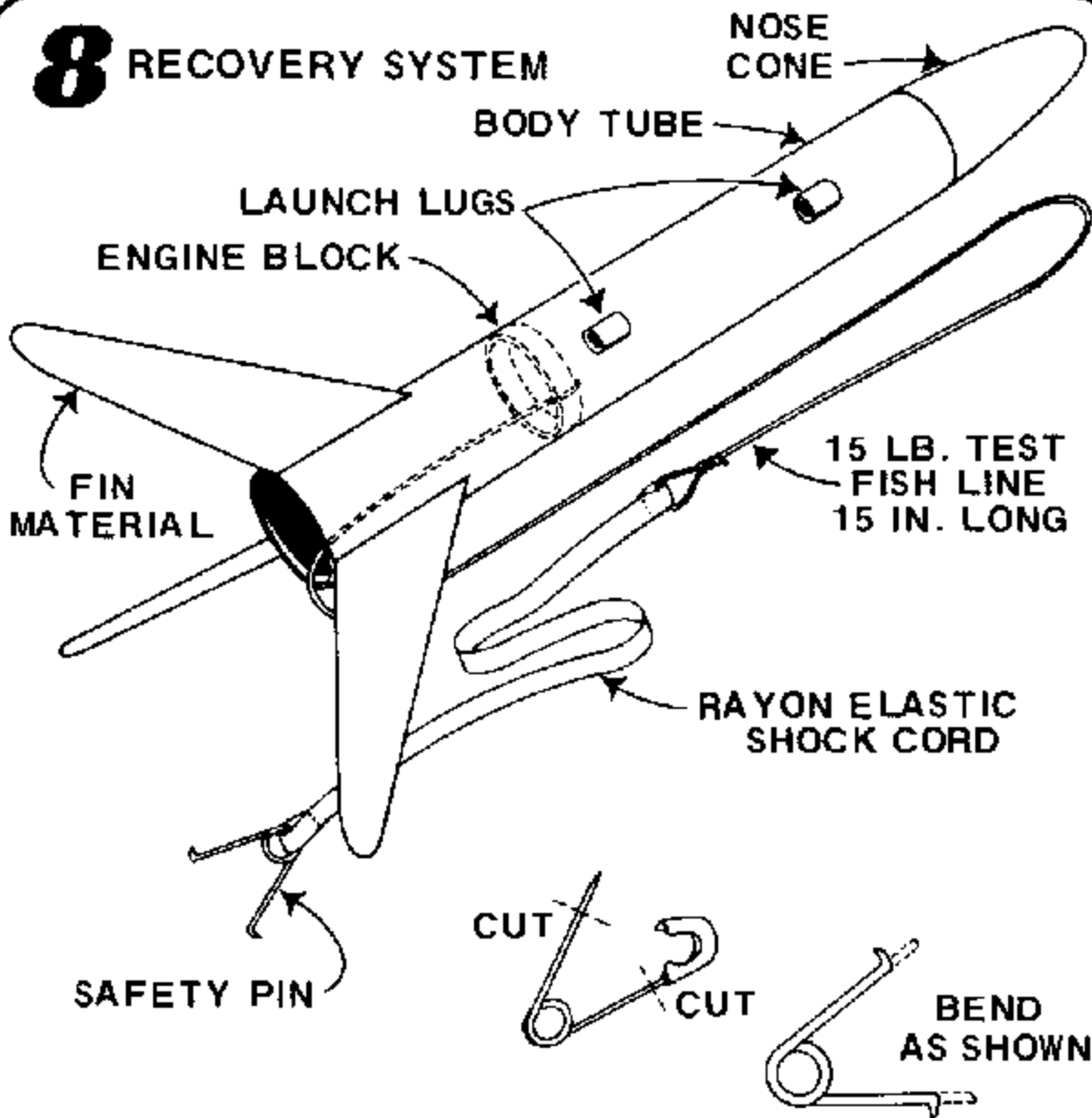

Spray the model with one coat of colored enamel AFTER completing the finishing procedures in Step 10. Orange is a high visibility color. (The original model was painted orange with black numerals for the NAR number.) Let the paint dry completely, and then rub down the entire model lightly with rubbing compound.

Rig the recovery system as shown. The rear ejection clip is made from a small safety pin as shown in the illustration.

9 LAUNCH CONFIGURATION

When preparing the model for flight, form the fishing line into a coil by wrapping it around a finger. A small sleeve made from a 1/8" diameter soda straw can be used to hold the coil when it is inserted into the body tube. Press the rear ejection clip firmly into the front end of the engine. Place two squares of recovery wadding (crumpled) on top of the engine as you insert it into the rocket. If the engine tends to slip out of the body tube, wrap some masking tape around it. Make sure the fit is not too tight to insure proper ejection.

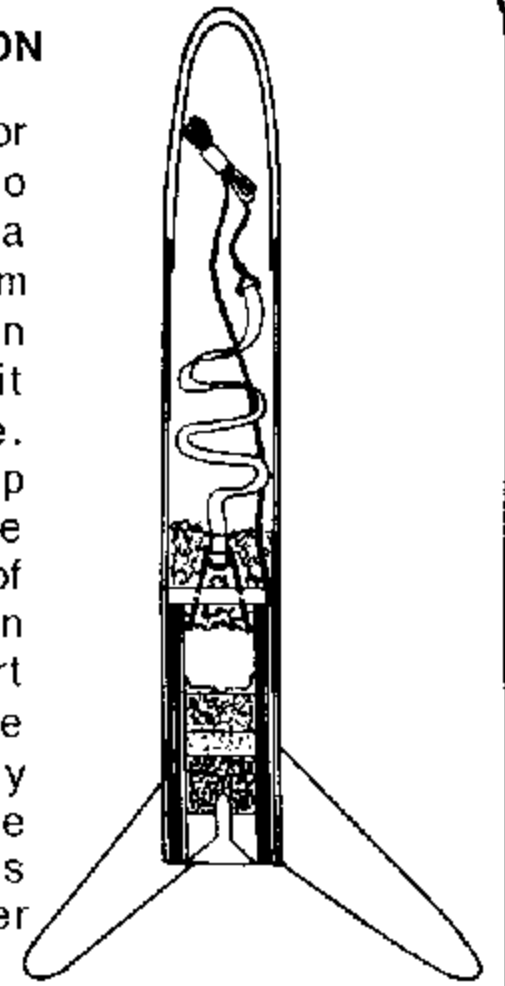

10

The Effort III was designed with minimum weight and drag in mind. Therefore the margin of stability is also at a minimum. The model you build might tend to be slightly unstable on its first flight (in that it might oscillate on the ascent), but you can correct this by adding a small amount of weight inside the hollow nose cone.

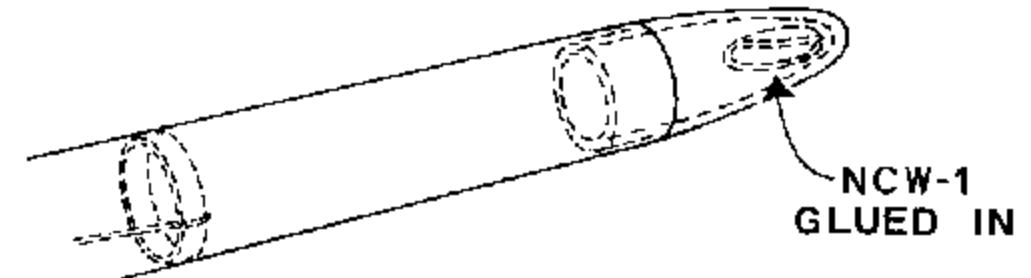

If the rocket is not stable, bend one lead weight (NCW-1) and glue it inside the nose cone as far as it will go. Relaunch. You can also use 0.12 oz. of balancing weights (NCW-3) or the equivalent weight in modeling clay. The model will only be stable with short 1/4A or 1/2A engines. However, you'll find the maximum design efficiency can be obtained with these small engines. The original national contest winner achieved an unofficial altitude of 204 meters and an overall efficiency of 81% with a 1/2A6-4S.

Once the model has been tested and is stable, glue in the nose cone.

FINISHING PROCEDURES

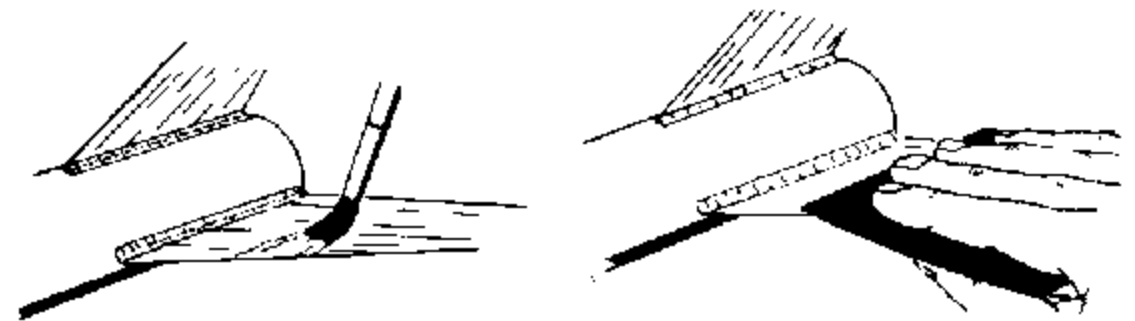

Begin the finish on the model by sanding it lightly with 320 grit, mylar-backed sanding material. Pay special attention to the nose cone, the nose-body joint, and the fins. Cover the entire model (body tube included) with a light coat of sanding sealer. Allow to dry completely.

Repeat the sanding and sanding sealer process on the nose cone, nose-body joint, and the fins until the entire outside surface of the model is smooth.